

MATLAB®

External Interfaces

R2013a

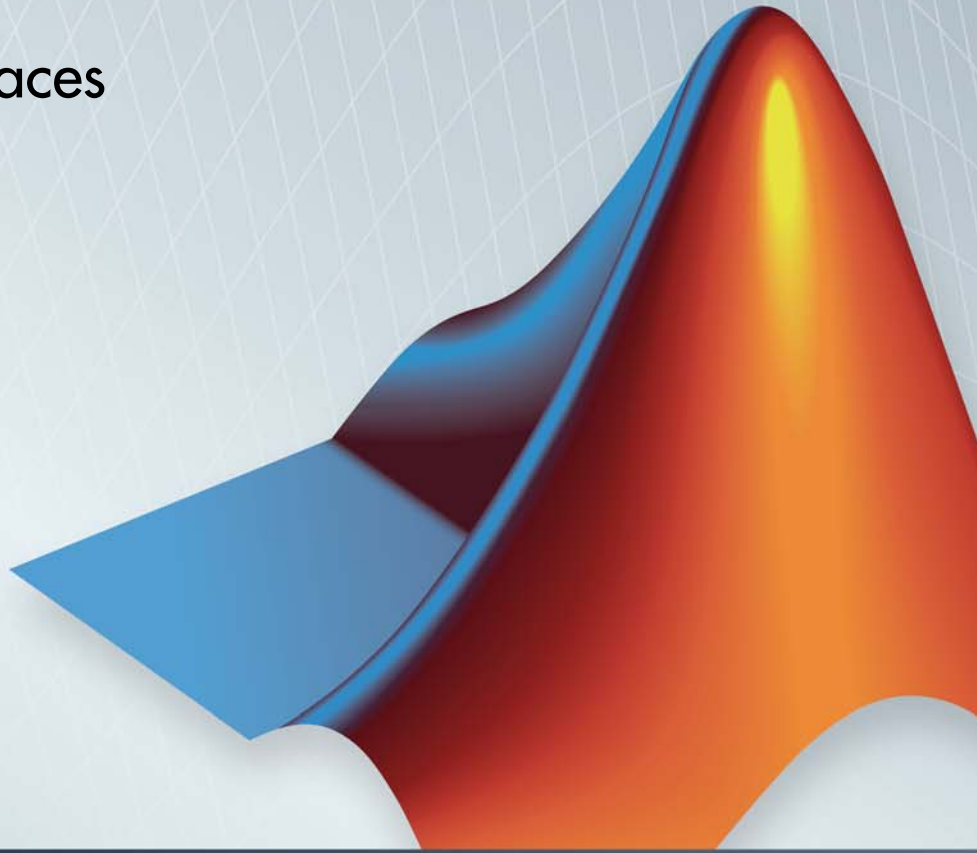

MATLAB®



How to Contact MathWorks



www.mathworks.com
comp.soft-sys.matlab
www.mathworks.com/contact_TS.html

Web
Newsgroup
Technical Support



suggest@mathworks.com
bugs@mathworks.com
doc@mathworks.com
service@mathworks.com
info@mathworks.com

Product enhancement suggestions
Bug reports
Documentation error reports
Order status, license renewals, passcodes
Sales, pricing, and general information



508-647-7000 (Phone)



508-647-7001 (Fax)



The MathWorks, Inc.
3 Apple Hill Drive
Natick, MA 01760-2098

For contact information about worldwide offices, see the MathWorks Web site.

MATLAB® External Interfaces

© COPYRIGHT 1984–2013 by The MathWorks, Inc.

The software described in this document is furnished under a license agreement. The software may be used or copied only under the terms of the license agreement. No part of this manual may be photocopied or reproduced in any form without prior written consent from The MathWorks, Inc.

FEDERAL ACQUISITION: This provision applies to all acquisitions of the Program and Documentation by, for, or through the federal government of the United States. By accepting delivery of the Program or Documentation, the government hereby agrees that this software or documentation qualifies as commercial computer software or commercial computer software documentation as such terms are used or defined in FAR 12.212, DFARS Part 227.72, and DFARS 252.227-7014. Accordingly, the terms and conditions of this Agreement and only those rights specified in this Agreement, shall pertain to and govern the use, modification, reproduction, release, performance, display, and disclosure of the Program and Documentation by the federal government (or other entity acquiring for or through the federal government) and shall supersede any conflicting contractual terms or conditions. If this License fails to meet the government's needs or is inconsistent in any respect with federal procurement law, the government agrees to return the Program and Documentation, unused, to The MathWorks, Inc.

Trademarks

MATLAB and Simulink are registered trademarks of The MathWorks, Inc. See www.mathworks.com/trademarks for a list of additional trademarks. Other product or brand names may be trademarks or registered trademarks of their respective holders.

Patents

MathWorks products are protected by one or more U.S. patents. Please see www.mathworks.com/patents for more information.

Revision History

December 1996	First printing	New for MATLAB 5 (release 8)
July 1997	Online only	Revised for MATLAB 5.1 (Release 9)
January 1998	Second printing	Revised for MATLAB 5.2 (Release 10)
October 1998	Third printing	Revised for MATLAB 5.3 (Release 11)
November 2000	Fourth printing	Revised and renamed for MATLAB 6.0 (Release 12)
June 2001	Online only	Revised for MATLAB 6.1 (Release 12.1)
July 2002	Online only	Revised for MATLAB 6.5 (Release 13)
January 2003	Online only	Revised for MATLAB 6.5.1 (Release 13SP1)
June 2004	Online only	Revised for MATLAB 7.0 (Release 14)
October 2004	Online only	Revised for MATLAB 7.0.1 (Release 14SP1)
September 2005	Online only	Revised for MATLAB 7.1 (Release 14SP3)
March 2006	Online only	Revised for MATLAB 7.2 (Release 2006a)
September 2006	Online only	Revised for MATLAB 7.3 (Release 2006b)
March 2007	Online only	Revised for MATLAB 7.4 (Release 2007a)
September 2007	Online only	Revised for MATLAB 7.5 (Release 2007b)
March 2008	Online only	Revised for MATLAB 7.6 (Release 2008a)
October 2008	Online only	Revised for MATLAB 7.7 (Release 2008b)
March 2009	Online only	Revised for MATLAB 7.8 (Release 2009a)
September 2009	Online only	Revised for MATLAB 7.9 (Release 2009b)
March 2010	Online only	Revised for MATLAB 7.10 (Release 2010a)
September 2010	Online only	Revised for MATLAB 7.11 (Release 2010b)
April 2011	Online only	Revised for MATLAB 7.12 (Release 2011a)
September 2011	Online only	Revised for MATLAB 7.13 (Release 2011b)
March 2012	Online only	Revised for MATLAB 7.14 (Release 2012a)
September 2012	Online only	Revised for MATLAB 8.0 (Release 2012b)
March 2013	Online only	Revised for MATLAB 8.1 (Release 2013a)

Read and Write MATLAB MAT-Files in C/C++ and Fortran

1

Writing Custom Applications to Read and Write	
MAT-Files	1-2
Why Write Custom Applications?	1-2
What You Need	1-3
MAT-File Interface Library	1-4
Finding Associated Files	1-5
Exchanging Data Files Between Platforms	1-6
Copy External Data into MAT-File Format with	
Standalone Programs	1-8
Overview of matimport.c Example	1-8
Declare Variables for External Data	1-9
Create mxArray Variables	1-10
Create MATLAB Variable Names	1-10
Read External Data into mxArray Data	1-10
Create and Open MAT-File	1-11
Write mxArray Data to File	1-11
Clean Up	1-11
Build the Application	1-11
Create the MAT-File	1-12
Import Data into MATLAB	1-12
Create MAT-File in C	1-13
Create MAT-File in C++	1-14
Read MAT-File in C/C++	1-15
Create MAT-File in Fortran	1-16
Read MAT-File in Fortran	1-17

Work with mxArray	1-18
Read Structures from a MAT-File	1-18
Read Cell Arrays from a MAT-File	1-19
Table of MAT-File Source Code Files	1-21
Compiling and Linking MAT-File Programs	1-22
Building on UNIX Operating Systems	1-22
Building on Windows Operating Systems	1-23
Deploying MAT-File Applications	1-24

Calling C Shared Library Functions from MATLAB

2

Calling Functions in Shared Libraries	2-3
What Is a Shared Library?	2-3
Selecting a C Compiler	2-4
Loading and Unloading the Library	2-4
Viewing Library Functions	2-5
Invoking Library Functions	2-8
Limitations to Shared Library Support	2-9
MATLAB Supports C Library Routines	2-9
Workarounds for Loading C++ Libraries	2-9
Using Bit Fields	2-10
Using Enum Declarations	2-11
Unions Not Supported	2-11
Compiler Dependencies	2-12
Limitations Using Structures	2-12
Limitations Using Pointers	2-12
Functions with Variable Number of Input Arguments Not Supported	2-13
Troubleshooting Shared Library Applications	2-14
Module Not Found Error	2-15

No Matching Signature Error	2-16
MATLAB Crashes Making a Function Call to a Shared Library	2-17
Passing Arguments to Shared Library Functions	2-18
C and MATLAB Equivalent Types	2-18
Passing Arguments	2-20
Passing a NULL Pointer	2-21
Manually Converting Data Passed to Functions	2-22
Shared Library shrlibsample.c	2-23
Pass String Arguments	2-25
Pass Structures	2-27
Add Values of Fields in Structure	2-27
Preconvert MATLAB Structure Before Adding Values ...	2-28
Display Structure Field Names	2-29
Pass Enumerated Types	2-30
Call readEnum Function with Enumeration String	2-30
Call Function with Integer Equivalent of Enumeration ...	2-30
Call Function with enum Pointer Type	2-31
Pass Pointers	2-32
Pass Primitive MATLAB Type	2-32
Pass Arrays	2-33
Two Dimensional MATLAB Arrays	2-33
More than Two Dimensional MATLAB Arrays	2-34
Iterate Through an Array	2-36
Create Cell Array from libpointer	2-36
Perform Pointer Arithmetic on Structure Array	2-37
Working with Pointer Arguments	2-39
Pointer Arguments in C Functions	2-39
The libpointer Object	2-39

Creating a Pointer to a Primitive Type	2-41
Creating a Pointer to a Structure	2-44
Passing a Pointer to the First Element of an Array	2-46
Putting a String into a Void Pointer	2-47
Passing an Array of Strings	2-47
Memory Allocation for an External Library	2-49
Multilevel Pointers	2-50
Working with Structure Arguments	2-53
Structure Argument Requirements	2-53
Finding Structure Field Names	2-53
Strategies for Passing Structures	2-53
Work with libstruct Objects	2-55
MATLAB Prototype Files	2-57
How to Create a Prototype File	2-58
How to Specify a Thunk file	2-58
Deploy Applications That Use loadlibrary	2-58
Use loadlibrary in a Parallel Computing Environment ...	2-58
Change Function Signature	2-58
Rename Library Function	2-58
Load Subset of Functions in Library	2-59
Call Function with Variable Number of Arguments	2-59
Create Alias Function Name Using Prototype File	2-60

Intro to MEX-Files

3

Introducing MEX-Files	3-2
What Are MEX-Files?	3-2
Definition of MEX	3-3
MEX and MX Matrix Libraries	3-3
Introduction to Source MEX-Files	3-3
Overview of Creating a Binary MEX-File	3-4
Configuring Your Environment	3-4

MEX-Files Call C/C++ and Fortran Programs	3-5
Creating a Source MEX-File	3-5
Workflow of a MEX-File	3-10
Using Binary MEX-Files	3-16
Binary MEX-File Placement	3-17
Using Help Files with MEX-Files	3-17
Workspace for MEX-File Functions	3-17
MATLAB Data	3-18
The MATLAB Array	3-18
Lifecycle of mxArray	3-18
Data Storage	3-20
MATLAB Types	3-21
Sparse Matrices	3-23
Using Data Types	3-23
Testing for Most-Derived Class	3-25
Build MEX-Files	3-27
What You Need to Build MEX-Files	3-27
Selecting a Compiler on Windows Platforms	3-28
Selecting a Compiler on UNIX Platforms	3-33
Linking Multiple Files	3-36
Overview of Building the timestwo MEX-File	3-36
Table of MEX-File Source Code Files	3-38
Custom Building MEX-Files	3-43
When to Use Custom Building	3-43
MEX Script Switches	3-43
Custom Building on UNIX Systems	3-47
Custom Building on Windows Systems	3-52
Call LAPACK and BLAS Functions	3-59
What You Need to Know	3-59
Creating a MEX-File Using LAPACK and BLAS Functions	3-60
Preserving Input Values from Modification	3-62
Passing Arguments to Fortran Functions from C/C++ Programs	3-63
Passing Arguments to Fortran Functions from Fortran Programs	3-64

Handling Complex Numbers in LAPACK and BLAS	
Functions	3-65
Modifying the Function Name on UNIX Systems	3-69
Running MEX-Files with .DLL File Extensions on	
Windows 32-bit Platforms	3-70
Upgrade MEX-Files to Use 64-Bit API	3-71
MATLAB Support for 64-Bit Indexing	3-71
MEX Uses 32-Bit API by Default	3-71
What If I Do Not Upgrade?	3-73
How to Upgrade MEX-Files to Use the 64-Bit API	3-75
Platform Compatibility	3-84
Verify the MEX-File Is Built For Your Platform	3-84
Verify Your Architecture on Windows Platforms	3-84
Invalid MEX-File Error	3-85
MATLAB Version Incompatibility	3-85
DLL Files Not on Path on Windows Systems	3-85
Before You Run a MEX-File You Receive from Someone	
Else	3-86
Version Compatibility	3-87
Troubleshooting MEX-Files	3-88
Technical Support	3-88
Configuration Issues	3-89
Search Path Problem on Microsoft Windows Systems	3-89
MATLAB Path Names Containing Spaces on Windows	
Systems	3-89
Internal Error When Using mex -setup ()	3-89
Understanding MEX-File Problems	3-91
Problem 1 — Compiling a Source MEX-File Fails	3-92
Problem 2 — Compiling Your Own Program Fails	3-92
Problem 3 — Binary MEX-File Load Errors	3-93
Problem 4 — Segmentation Fault	3-94

Problem 5 — Program Generates Incorrect Results	3-94
Compiler- and Platform-Specific Issues	3-96
Linux gcc Compiler Version Error	3-96
Linux gcc -fPIC Errors	3-96
Watcom IDE Unresolved References	3-96
Memory Management Issues	3-97
Overview	3-97
Improperly Destroying an mxArray	3-98
Incorrectly Constructing a Cell or Structure mxArray	3-98
Creating a Temporary mxArray with Improper Data	3-99
Creating Potential Memory Leaks	3-100
Improperly Destroying a Structure	3-101
Destroying Memory in a C++ Class Destructor	3-102
Compiler Errors in Fortran MEX-Files	3-103

C/C++ MEX-Files

4

C/C++ Source MEX-Files	4-2
The Components of a C/C++ MEX-File	4-2
Gateway Routine	4-2
Computational Routine	4-5
Preprocessor Macros	4-5
Data Flow in MEX-Files	4-5
Creating C++ MEX-Files	4-9
Set Up C/C++ Examples	4-11
Pass Scalar Values	4-12
Pass Strings	4-14
Pass Multiple Inputs or Outputs	4-16

Pass Structures and Cell Arrays	4-18
Create 2-D Cell Array	4-20
Fill mxArray	4-21
Copying Data Directly into an mxArray	4-21
Pointing to Data	4-21
Prompt User for Input	4-22
Handle Complex Data	4-23
Handle 8-, 16-, and 32-Bit Data	4-24
Manipulate Multidimensional Numerical Arrays	4-25
Handle Sparse Arrays	4-27
Call MATLAB Functions from C/C++ MEX-Files	4-28
Use C++ Features in MEX-Files	4-29
Handle Files with C++	4-30
C Example	4-30
C++ Example	4-31
Debug C/C++ Language MEX-Files	4-32
Notes on Debugging	4-32
Debugging on the Microsoft Windows Platforms	4-32
Debugging on Linux Platforms	4-40
Handling Large mxArray	4-43
Using the 64-Bit API	4-43
Building the Binary MEX-File	4-45
Example	4-45
Caution Using Negative Values	4-46
Building Cross-Platform Applications	4-46

Memory Management	4-47
Automatic Cleanup of Temporary Arrays	4-47
Persistent Arrays	4-48
Handling Large File I/O	4-50
Prerequisites to Using 64-Bit I/O	4-50
Specifying Constant Literal Values	4-52
Opening a File	4-53
Printing Formatted Messages	4-54
Replacing fseek and ftell with 64-Bit Functions	4-54
Determining the Size of an Open File	4-55
Determining the Size of a Closed File	4-56

Fortran MEX-Files

5

Fortran Source MEX-Files	5-2
The Components of a Fortran MEX-File	5-2
Gateway Routine	5-2
Computational Routine	5-5
Preprocessor Macros	5-5
Using the Fortran %val Construct	5-6
Data Flow in MEX-Files	5-7
Set Up Fortran Examples	5-12
Pass Scalar Values	5-13
Pass Strings	5-14
Pass Arrays of Strings	5-15
Pass Matrices	5-16
Pass Integers	5-17
Pass Multiple Inputs or Outputs	5-18

Handle Complex Data	5-19
Dynamically Allocate Memory	5-20
Handle Sparse Matrices	5-21
Call MATLAB Functions from Fortran MEX-Files	5-22
Debug Fortran Source MEX-Files	5-24
Notes on Debugging	5-24
Debugging on Microsoft Windows Platforms	5-24
Debugging on Linux Platforms	5-24
Handling Large mxArray Arrays	5-27
Using the 64-Bit API	5-27
Building the Binary MEX-File	5-29
Caution Using Negative Values	5-29
Building Cross-Platform Applications	5-29
Memory Management	5-30

Calling MATLAB Engine from C/C++ and Fortran Programs

6

Using MATLAB Engine	6-2
Introduction to MATLAB Engine	6-2
What You Need to Build Engine Applications	6-3
The Engine Library	6-4
GUI-Intensive Applications	6-5
Call MATLAB Functions from C Applications	6-6
Call MATLAB Functions from C++ Applications	6-8
Call MATLAB Functions from Fortran Applications ..	6-9

Attach to Existing MATLAB Sessions	6-11
Compiling Engine Applications with MEX Command ..	6-13
Requirements to Build and Run Engine Applications	6-13
Building and Running Engine Applications on Windows	
Operating Systems	6-14
Windows Engine Example engwindemo	6-16
Building and Running Engine Applications on UNIX	
Operating Systems	6-17
UNIX Engine Example engdemo	6-18
Compiling Engine Applications with IDE	6-19
Configuring the IDE	6-19
Files Required by Engine Applications	6-19
Troubleshooting Engine Applications	6-23
Can't Start MATLAB Engine Message	6-23
Debugging MATLAB Functions Used in Engine	
Applications	6-23

Using Java Libraries from MATLAB

7

Overview of Java Interface	7-2
Java Interface Is Integral to MATLAB	7-2
Benefits of the MATLAB Java Interface	7-2
Who Should Use the MATLAB Java Interface	7-2
To Learn More About Java Programming Language	7-3
Platform Support for JVM Software	7-3
Bringing Java Classes into MATLAB Workspace	7-4
Introduction	7-4
Sources of Java Classes	7-4
Defining New Java Classes	7-5
The Java Class Path	7-5
Making Java Classes Available in MATLAB Workspace ..	7-8
Loading Java Class Definitions	7-10
Simplifying Java Class Names	7-10
Locating Native Method Libraries	7-11

Java Classes Contained in a JAR File	7-12
Creating and Using Java Objects	7-13
Overview	7-13
Constructing Java Objects	7-13
Concatenating Java Objects	7-16
Saving and Loading Java Objects to MAT-Files	7-17
Finding the Public Data Fields of an Object	7-18
Accessing Private and Public Data	7-18
Determining the Class of an Object	7-20
Invoking Methods on Java Objects	7-21
Calling Syntax	7-21
Obtaining Information About Methods	7-23
Java Methods That Affect MATLAB Commands	7-27
How MATLAB Handles Undefined Methods	7-28
How MATLAB Handles Java Exceptions	7-29
Method Execution in MATLAB	7-29
Working with Java Arrays	7-30
Introduction	7-30
How MATLAB Represents the Java Array	7-30
Creating an Array of Objects in MATLAB	7-35
Accessing Elements of a Java Array	7-37
Assigning to a Java Array	7-41
Concatenating Java Arrays	7-44
Creating a New Array Reference	7-46
Creating a Copy of a Java Array	7-46
Passing Data to Java Methods	7-48
Introduction	7-48
Conversion of MATLAB Argument Data	7-48
Passing Built-In Types	7-50
Passing String Arguments	7-51
Passing Java Objects	7-52
Other Data Conversion Topics	7-55
Passing Data to Overloaded Methods	7-56
Handling Data Returned from Java Methods	7-59
Introduction	7-59
Conversion of Java Return Types	7-59
Built-In Types	7-60

Java Objects	7-60
Converting Objects to MATLAB Types	7-61
Read URL	7-66
Overview	7-66
Description of URLdemo	7-66
Running the Example	7-67
Find Internet Protocol Address	7-69
Overview	7-69
Description of resolveip	7-69
Running the Example	7-70
Create and Use Phone Book	7-71
Overview	7-71
Description of Function phonebook	7-72
Description of Function pb_lookup	7-76
Description of Function pb_add	7-77
Description of Function pb_remove	7-78
Description of Function pb_change	7-79
Description of Function pb_listall	7-80
Description of Function pb_display	7-81
Description of Function pb_keyfilter	7-81
Running the phonebook Program	7-82

Using .NET Libraries from MATLAB

8

Overview Using .NET from MATLAB	8-3
What Is the Microsoft .NET Framework?	8-3
Benefits of the MATLAB .NET Interface	8-3
Why Use the MATLAB .NET Interface?	8-3
Limitations to .NET Support	8-4
What's the Difference Between the MATLAB .NET Interface and MATLAB Builder NE?	8-5
System Requirements	8-6
Using a .NET assembly in MATLAB	8-6
To Learn More About the .NET Framework	8-6

Getting Started with .NET	8-8
What is an Assembly?	8-8
.NET Terminology	8-9
Simplifying .NET Class Names	8-10
Loading .NET Assemblies into MATLAB	8-11
Handling Exceptions	8-12
Working With Nested Classes	8-12
Using a .NET Object	8-14
Creating a .NET Object	8-14
Building a .NET Application for MATLAB Examples	8-14
What Classes Are in a .NET Assembly?	8-15
Using the delete Function on a .NET Object	8-15
Using .NET Properties	8-17
How MATLAB Represents .NET Properties	8-17
How MATLAB Maps C# Property and Field Access Modifiers	8-18
Using .NET Methods in MATLAB	8-19
Calling .NET Methods	8-19
Calling .NET Generic Methods	8-21
Calling .NET Methods with Optional Arguments	8-21
Calling .NET Extension Methods	8-22
Call .NET Properties That Take an Argument	8-22
How MATLAB Represents .NET Operators	8-23
Limitations to Support of .NET Methods	8-24
Working with .NET Events in MATLAB	8-25
Use .NET Events in MATLAB	8-25
Limitations to Support of .NET Events	8-26
Using Arrays with .NET Applications	8-27
Passing MATLAB Arrays to .NET	8-27
Accessing .NET Array Elements in MATLAB	8-27
Converting .NET Arrays to Cell Arrays	8-28
Converting .NET Jagged Arrays to MATLAB Arrays	8-30
Limitations to Support of .NET Arrays	8-30
Pass Jagged Arrays	8-31
Create System.Double .NET Jagged Array	8-31

Call .NET Method with System.String Jagged Array	
Arguments	8-32
Call .NET Method with Multidimensional Jagged Array	
Arguments	8-33
.NET Delegates in MATLAB	8-35
.NET Delegates	8-35
Call .NET Delegates in MATLAB	8-36
Create Delegates from .NET Object Methods	8-37
Create Delegate Instances Bound to .NET Methods	8-38
Call Delegates With out and ref Type Arguments	8-39
Combine and Remove .NET Delegates	8-40
Calling .NET Methods Asynchronously	8-41
Limitations to Support of .NET Delegates	8-45
.NET Enumerations in MATLAB	8-46
Overview of .NET Enumerations	8-46
Default Methods for an Enumeration	8-47
Underlying Values	8-48
Using the NetDocEnum Example Assembly	8-49
Work with Members of a .NET Enumeration	8-49
Refer to a .NET Enumeration Member	8-51
Display .NET Enumeration Members as Character	
Strings	8-52
Convert .NET Enumeration Values to Type Double	8-52
Iterate Through a .NET Enumeration	8-52
Use .NET Enumerations to Test for Conditions	8-54
Use Bit Flags with .NET Enumerations	8-56
Read Special System Folder Path	8-59
Limitations to Support of .NET Enumerations	8-60
.NET Generic Classes in MATLAB	8-61
.NET Generic Classes	8-61
Accessing Items in .NET Collections	8-62
Create .NET Collections	8-62
Convert .NET Collections to MATLAB Arrays	8-64
Create .NET Arrays of Generic Type	8-65
Call .NET Generic Methods	8-66
Display .NET Generic Methods Using Reflection	8-68
Troubleshooting Security Policy Settings From	
Network Drives	8-72

Access a Simple .NET Class	8-73
System.DateTime Example	8-73
Create .NET Object From Constructor	8-74
View Information About .NET Object	8-74
Introduction to .NET Data Types	8-77
Load a Global .NET Assembly	8-79
Pass Numeric Arguments	8-80
Call .NET Methods with Numeric Arguments	8-80
Use .NET Numeric Types in MATLAB	8-80
Pass System.String Arguments	8-81
Call .NET Methods with System.String Arguments	8-81
Use System.String in MATLAB	8-82
Pass System.Enum Arguments	8-83
Call .NET Methods with System.Enum Arguments	8-83
Use System.Enum in MATLAB	8-84
Pass System.Nullable Arguments	8-86
Set Static .NET Properties	8-91
System.Environment.CurrentDirectory Example	8-91
Do Not Use ClassName.PropertyName Syntax for Static Properties	8-92
Use .NET Properties That Take Arguments	8-93
MATLAB Does Not Display Protected Properties	8-94
Examples Using .NET Methods	8-95
Work with .NET Methods Having Multiple Signatures ...	8-95
SampleMethods Class	8-97
Call .NET Methods With out Keyword	8-98
Call .NET Methods With ref Keyword	8-98
Call .NET Methods With params Keyword	8-99
Call .NET Methods with Optional Arguments	8-100

Setting Up the Examples	8-100
Skip Optional Arguments	8-100
Call Overloaded Methods	8-101
Pass Cell Arrays of .NET Data	8-104
Example of Cell Arrays of .NET Data	8-104
Create a Cell Array for Each System.Object	8-105
Create MATLAB Variables from the .NET Data	8-105
Call MATLAB Functions with MATLAB Variables	8-105
An Assembly is a Library of .NET Classes	8-107
Convert Nested System.Object Arrays	8-108
Passing Data to .NET Objects	8-109
Pass Primitive .NET Types	8-109
Pass Cell Arrays	8-110
Pass Nonprimitive .NET Objects	8-111
Pass MATLAB Strings	8-111
Pass System.Nullable Type	8-111
Pass NULL Values	8-112
Unsupported MATLAB Types	8-112
Choosing Method Signatures	8-112
Example — Choosing a Method Signature	8-113
Pass Arrays	8-115
Pass MATLAB Arrays as Jagged Arrays	8-115
Handling Data Returned from .NET Objects	8-117
.NET Type to MATLAB Type Mapping	8-117
How MATLAB Handles System.String	8-118
How MATLAB Handles System.__ComObject	8-119
How MATLAB Handles System.Nullable	8-120
How MATLAB Handles dynamic Type	8-121
How MATLAB Handles Jagged Arrays	8-121
Work with Microsoft Excel Spreadsheets Using .NET ..	8-123
Work with Microsoft Word Documents Using .NET ...	8-125

MATLAB COM Integration	9-2
What Is COM?	9-2
Concepts and Terminology	9-3
The MATLAB COM Client	9-5
The MATLAB COM Automation Server	9-6
Registering Controls and Servers	9-6
Getting Started with COM	9-8
Introduction to COM	9-8
Basic COM Functions	9-8
Use Internet Explorer Program in a MATLAB Figure ..	9-11
Techniques Demonstrated	9-11
Using the Figure to Access Properties	9-11
Complete Code Listing	9-12
Creating the Figure	9-13
Calculating the ActiveX Object Container Size	9-13
Automatic Resize	9-14
Selecting Graphics Objects	9-15
Closing the Figure	9-16
Add Grid ActiveX Control in a Figure	9-17
Techniques Demonstrated	9-17
Using the Control	9-17
Complete Code Listing	9-18
Preparing to Use the Control	9-19
Creating a Figure to Contain the Control	9-20
Creating an Instance of the Control	9-21
Using Mouse-Click Event to Plot Data	9-22
Managing Figure Resize	9-23
Closing the Figure	9-24
Read Excel Spreadsheet Data	9-25
Techniques Demonstrated	9-25
Using the GUI	9-25
Complete Code Listing	9-26
Excel Spreadsheet Format	9-26
Excel Automation Server	9-27

Manipulating the Data in the MATLAB Workspace	9-28
The Plotter GUI	9-29
Inserting MATLAB Graphs Into Excel Spreadsheets	9-31
Supported Client/Server Configurations	9-33
Introduction	9-33
MATLAB Client and In-Process Server	9-33
MATLAB Client and Out-of-Process Server	9-34
COM Implementations Supported by MATLAB	
Software	9-35
Client Application and MATLAB Automation Server	9-35
Client Application and MATLAB Engine Server	9-37

MATLAB COM Client Support

10

Creating COM Objects	10-2
Creating the Server Process — An Overview	10-2
Creating an ActiveX Control	10-3
Creating a COM Server	10-9
Explore COM Objects	10-12
About Your Object	10-12
Exploring Properties	10-12
Exploring Methods	10-14
Exploring Events	10-14
Exploring Interfaces	10-15
Identifying Objects and Interfaces	10-16
Use Object Properties	10-19
About Object Properties	10-19
Working with Multiple Objects	10-20
Using Enumerated Values for Properties	10-20
Using the Property Inspector	10-22
Custom Properties	10-24
Properties That Take Arguments	10-25
Use Methods	10-29
About Methods	10-29

Getting Method Information	10-30
Invoking Methods on an Object	10-34
Exceptions to Using Implicit Syntax	10-36
Specifying Enumerated Parameters	10-37
Optional Input Arguments	10-38
Returning Multiple Output Arguments	10-39
Argument Callouts in Error Messages	10-40
Use Events	10-42
About Events	10-42
Functions for Working with Events	10-43
Examples of Event Handlers	10-43
Responding to Events — an Overview	10-44
Responding to Events — Examples	10-46
Writing Event Handlers	10-54
Sample Event Handlers	10-57
Writing Event Handlers as MATLAB Local Functions ...	10-58
Getting Interfaces to COM Object	10-60
IUnknown and IDispatch Interfaces	10-60
Custom Interfaces	10-61
Save COM Objects	10-63
Functions for Saving and Restoring COM Objects	10-63
Releasing COM Interfaces and Objects	10-64
Handling COM Data in MATLAB Software	10-65
Passing Data to COM Objects	10-65
Handling Data from COM Objects	10-67
Unsupported Types	10-68
Passing MATLAB Data to ActiveX Objects	10-69
Passing MATLAB SAFEARRAY to COM Object	10-69
Reading SAFEARRAY from COM Objects in MATLAB	
Applications	10-71
Displaying MATLAB Syntax for COM Objects	10-72
Use MATLAB Application as Automation Client	10-76
MATLAB Sample Control	10-76
Using a MATLAB Application as an Automation Client ..	10-76
Connecting to an Existing Excel Application	10-78
Running a Macro in an Excel Server Application	10-79
MATLAB COM Client Example	10-80

Deploy ActiveX Controls Requiring Run-Time	
Licenses	10-81
Create a Function to Build the Control	10-81
Build the Control and the License File	10-81
Build the Executable	10-82
Deploy the Files	10-82
Use Microsoft Forms 2.0 Controls	10-83
Affected Controls	10-83
Replacement Controls	10-83
Use COM Collections	10-85
Use MATLAB Application as DCOM Client	10-86
MATLAB COM Support Limitations	10-87

MATLAB COM Automation Server Support

11

MATLAB COM Automation Server Interface	11-2
What Is Automation?	11-2
Creating the MATLAB Server	11-2
Connecting to an Existing MATLAB Server	11-5
MATLAB Automation Server Functions and	
Properties	11-7
Executing Commands in the MATLAB Server	11-7
Exchanging Data with the Server	11-9
Controlling the Server Window	11-10
Terminating the Server Process	11-10
Client-Specific Information	11-11
Using the Visible Property	11-11
Using MATLAB Application as DCOM Server	11-13
Using VT_DATE Data Type	11-14

Specifying Shared or Dedicated Server	11-15
Starting a Shared Server	11-15
Starting a Dedicated Server	11-15
Manually Create Automation Server	11-16
Launch MATLAB as Automation Server in Desktop Mode	11-17
Call MATLAB Function from Visual Basic .NET Client	11-18
Call MATLAB Function from Web Application	11-19
Call MATLAB Function from C# Client	11-22
View MATLAB Functions from Visual Basic .NET Object Browser	11-24

Using Web Services with MATLAB

12

How You Can Use Web Services with MATLAB	12-2
What Are Web Services in MATLAB?	12-2
What You Need to Use Web Services with MATLAB	12-3
Typical Applications Using Web Services with MATLAB ..	12-4
Ways of Using Web Services in MATLAB	12-5
Two Basic Ways to Access Web Services from MATLAB ..	12-5
How MATLAB Accesses Web Services	12-5
Access Web Services That Use WSDL Documents	12-6
Using the createClassFromWsdL Function	12-6
Example — createClassFromWsdL Function	12-7

Access Web Services Using MATLAB SOAP	
Functions	12-10
Using the MATLAB SOAP Functions	12-10
Example — SOAP Functions	12-10
Considerations When Using Web Services	12-13
XML-MATLAB Data Type Conversion Used in Web Services	12-13
Programming with Web Services	12-14
Where to Get Information About Web Services	12-16
Resources for Web Services and SOAP	12-16
Resources for WSDL	12-16
Tools for Creating Web Services	12-16

Serial Port I/O

13

Introduction	13-2
What Is the MATLAB Serial Port Interface?	13-2
Supported Serial Port Interface Standards	13-3
Supported Platforms	13-3
Using the Examples with Your Device	13-3
Overview of the Serial Port	13-5
Introduction	13-5
What Is Serial Communication?	13-5
The Serial Port Interface Standard	13-6
Connecting Two Devices with a Serial Cable	13-6
Serial Port Signals and Pin Assignments	13-7
Serial Data Format	13-11
Finding Serial Port Information for Your Platform	13-16
Using Virtual USB Serial Ports	13-18
Selected Bibliography	13-18
Getting Started with Serial I/O	13-20
Example: Getting Started	13-20
The Serial Port Session	13-21
Configuring and Returning Properties	13-22

Creating a Serial Port Object	13-27
Overview of a Serial Port Object	13-27
Configuring Properties During Object Creation	13-29
The Serial Port Object Display	13-29
Creating an Array of Serial Port Objects	13-30
Connecting to the Device	13-32
Configuring Communication Settings	13-33
Writing and Reading Data	13-34
Before You Begin	13-34
Example — Introduction to Writing and Reading Data ...	13-34
Controlling Access to the MATLAB Command Line	13-35
Writing Data	13-36
Reading Data	13-42
Example — Writing and Reading Text Data	13-48
Example — Parsing Input Data Using textscan	13-50
Example — Reading Binary Data	13-51
Events and Callbacks	13-55
Introduction	13-55
Example — Introduction to Events and Callbacks	13-56
Event Types and Callback Properties	13-56
Responding To Event Information	13-59
Creating and Executing Callback Functions	13-61
Enabling Callback Functions After They Error	13-62
Example — Using Events and Callbacks	13-62
Using Control Pins	13-65
Properties of Serial Port Control Pins	13-65
Signaling the Presence of Connected Devices	13-65
Controlling the Flow of Data: Handshaking	13-68
Debugging: Recording Information to Disk	13-71
Introduction	13-71
Recording Properties	13-71
Example: Introduction to Recording Information	13-72
Creating Multiple Record Files	13-72
Specifying a Filename	13-73
The Record File Format	13-73

Example: Recording Information to Disk	13-74
Saving and Loading	13-78
Using save and load	13-78
Using Serial Port Objects on Different Platforms	13-79
Disconnecting and Cleaning Up	13-80
Disconnecting a Serial Port Object	13-80
Cleaning Up the MATLAB Environment	13-80
Property Reference	13-82
The Property Reference Page Format	13-82
Serial Port Object Properties	13-82
Properties — Alphabetical List	13-86

Index

|

Read and Write MATLAB MAT-Files in C/C++ and Fortran

- “Writing Custom Applications to Read and Write MAT-Files” on page 1-2
- “Copy External Data into MAT-File Format with Standalone Programs” on page 1-8
- “Create MAT-File in C” on page 1-13
- “Create MAT-File in C++” on page 1-14
- “Read MAT-File in C/C++” on page 1-15
- “Create MAT-File in Fortran” on page 1-16
- “Read MAT-File in Fortran” on page 1-17
- “Work with mxArray” on page 1-18
- “Table of MAT-File Source Code Files” on page 1-21
- “Compiling and Linking MAT-File Programs” on page 1-22

Writing Custom Applications to Read and Write MAT-Files

In this section...
“Why Write Custom Applications?” on page 1-2
“What You Need” on page 1-3
“MAT-File Interface Library” on page 1-4
“Finding Associated Files” on page 1-5
“Exchanging Data Files Between Platforms” on page 1-6

Why Write Custom Applications?

To bring data into a MATLAB® application, see “Recommended Methods for Importing Data”. To save data to a MAT-file, see “Save, Load, and Delete Workspace Variables”. Use these procedures when you program your entire application in MATLAB, or if you share data with other MATLAB users. There are situations, however, when you must write a custom program to interact with data. For example:

- Your data has a custom format.
- You create applications for users who do not run MATLAB, and you want to provide them with MATLAB data.
- You want to read data from an external application, but you do not have access to the source code.

Before writing a custom application, determine if MATLAB meets your data exchange needs by reviewing the following topics:

- The save and load functions.
- “Supported File Formats”.
- The importdata function and “Tips for Using the Import Wizard”.
- “Recommended Methods for Importing Data”.

If these features are not sufficient, you can create custom C/C++ or Fortran programs to read and write data files in the format required by your application. There are two types of custom programs:

- Standalone program — Run from a system prompt or execute in MATLAB (see Run External Commands, Scripts, and Programs). Requires MATLAB libraries to build the application.
- MEX-file — Built and executed from the MATLAB command prompt. For information about creating and building MEX-Files, see “Introducing MEX-Files” on page 3-2.

What You Need

To create a custom application, you need the tools and knowledge to modify and build source code. In particular, you need a compiler supported by MATLAB. For an up-to-date list of supported compilers, see the Supported and Compatible Compilers Web page.

To exchange custom data with MATLAB data, use a *MAT-file*, a MATLAB format binary file. You need to know the details of your data to map it into MATLAB data. Get this information from your product documentation. Use the `mxArray` type in the MX Matrix Library for data in your program.

In your custom program, use functions in the MATLAB C/C++ and Fortran API:

- “MAT-Function Include Files” on page 1-5
- “MAT-File Interface Library” on page 1-4
- MX Matrix Library

To build the application, use the `mex` build script with the compiler-specific *options file* for MAT-file applications. MATLAB provides the header files and libraries, and guidance for creating a build script. For names and locations of required files, see “MAT-Function Libraries” on page 1-6.

You can also use your own build tools.

MAT-File Interface Library

The MAT-File Library contains routines for reading and writing MAT-files. Call these routines from your own C/C++ and Fortran programs. Use these routines, rather than attempt to write your own code, to perform these operations, since using the library insulates your applications from future changes to the MAT-file structure.

MATLAB provides the `MATfile` type for representing a MAT-file.

Do not create different MATLAB sessions on different threads using MAT-File Library functions. MATLAB libraries are not multithread safe so you can use these functions only on a single thread at a time.

Functions in the MAT-file Library, described in the following tables, begin with the three-letter prefix `mat`.

MAT-File Routines

MAT-Function	Purpose
<code>matOpen</code>	Open a MAT-file.
<code>matClose</code>	Close a MAT-file.
<code>matGetDir</code>	Get a list of MATLAB arrays from a MAT-file.
<code>matGetVariable</code>	Read a MATLAB array from a MAT-file.
<code>matPutVariable</code>	Write a MATLAB array to a MAT-file.
<code>matGetNextVariable</code>	Read the next MATLAB array from a MAT-file.
<code>matDeleteVariable</code>	Remove a MATLAB array from a MAT-file.
<code>matPutVariableAsGlobal</code>	Put a MATLAB array into a MAT-file such that the load command places it into the global workspace.
<code>matGetVariableInfo</code>	Load a MATLAB array header from a MAT-file (no data).
<code>matGetNextVariableInfo</code>	Load the next MATLAB array header from a MAT-file (no data).

MAT-File C-Only Routines

<code>matGetFp</code>	Get an ANSI [®] C file pointer to a MAT-file.
-----------------------	--

Note The MAT-File Interface Library does not support MATLAB objects created by user-defined classes.

Finding Associated Files

MATLAB provides the include and library files needed to write programs to read and write MAT-files. The following table lists the path names to these files. The term *matlabroot* refers to the root folder of your MATLAB installation. The term *arch* is a unique string identifying the platform.

MAT-Function Folders

Platform	Contents	Folder
Microsoft [®] Windows [®]	Include files	<i>matlabroot</i> \extern\include
	Libraries	<i>matlabroot</i> \bin\win32 or <i>matlabroot</i> \bin\win64
	Examples	<i>matlabroot</i> \extern\examples\eng_mat
UNIX [®]	Include files	<i>matlabroot</i> /extern/include
	Libraries	<i>matlabroot</i> /bin/ <i>arch</i>
	Examples	<i>matlabroot</i> /extern/examples/eng_mat

MAT-Function Include Files

The `include` folder holds header files containing function declarations with prototypes for the routines that you can access in the API Library. These files are the same for both Windows and UNIX systems. The folder contains:

- The `matrix.h` header file that contains a definition of the `mxArray` structure and function prototypes for matrix access routines.
- The `mat.h` header file that contains function prototypes for `mat` routines.

MAT-Function Libraries

The name of the libraries folder, which contains shared (dynamically linkable) libraries for linking your programs, is platform-dependent.

Shared Libraries on Windows Systems. The `bin` folder contains the shared libraries for linking your programs:

- The `libmat.dll` library of MAT-file routines (C/C++ and Fortran)
- The `libmx.dll` library of array access and creation routines

Shared Libraries on UNIX Systems. The `bin/arch` folder, where *arch* is your machine's architecture, contains the shared libraries for linking your programs. For example, on Apple Macintosh 64-bit systems, the folder is `bin/maci64`:

- The `libmat.dylib` library of MAT-file routines (C/C++ and Fortran)
- The `libmx.dylib` library of array access and creation routines

Example Files

The `examples/eng_mat` folder contains C/C++ and Fortran source code for examples demonstrating how to use the MAT-file routines.

Exchanging Data Files Between Platforms

You can work with MATLAB software on different computer systems and send MATLAB applications to users on other systems. MATLAB applications consist of MATLAB code containing functions and scripts, and MAT-files containing binary data.

Both types of files can be transported directly between machines: MATLAB source files because they are platform independent, and MAT-files because they contain a machine signature in the file header. MATLAB checks the signature when it loads a file and, if a signature indicates that a file is foreign, performs the necessary conversion.

Using MATLAB across different machine architectures requires a facility for exchanging both binary and ASCII data between the machines. Examples of this type of facility include FTP, NFS, and Kermit. When using these

programs, be careful to transmit MAT-files in *binary file mode* and MATLAB source files in *ASCII file mode*. Failure to set these modes correctly corrupts the data.

Copy External Data into MAT-File Format with Standalone Programs

In this section...

“Overview of `matimport.c` Example” on page 1-8
“Declare Variables for External Data” on page 1-9
“Create `mxArray` Variables” on page 1-10
“Create MATLAB Variable Names” on page 1-10
“Read External Data into `mxArray` Data” on page 1-10
“Create and Open MAT-File” on page 1-11
“Write `mxArray` Data to File” on page 1-11
“Clean Up” on page 1-11
“Build the Application” on page 1-11
“Create the MAT-File” on page 1-12
“Import Data into MATLAB” on page 1-12

Overview of `matimport.c` Example

This topic shows how to create a standalone program, `matimport`, to copy data from an external source into a MAT-file. The format of the data is custom, that is, it is not one of the file formats supported by MATLAB.

The `matimport.c` example:

- Creates variables to read the external data.
- Copies the data into `mxArray` variables.
- Assigns a variable name to each `mxArray`. This is the variable name to use in the MATLAB workspace.
- Writes the `mxArray` variables and associated variable names to the MAT-file.

To use the data in MATLAB:

- Build the standalone program `matimport`.
- Run `matimport` to create the MAT-file `matimport.mat`.
- Open MATLAB.
- Use one of the techniques described in “Save, Load, and Delete Workspace Variables”.

The following topics describe these steps in detail. To see the code, open the file in the MATLAB Editor. The C statements in these topics are code snippets shown to illustrate a task. The statements in the topics are not necessarily sequential in the source file.

Declare Variables for External Data

There are two external data values, a string and an array of type `double`. The following table shows the relationship between the variables in this example.

External Data	Variable to Read External Data	mxArray Variable	MATLAB Variable Name
Array of type <code>double</code>	<code>extData</code>	<code>pVarNum</code>	<code>inputArray</code>
String	<code>extString</code>	<code>pVarChar</code>	<code>titleString</code>

The following statements declare the type and size for variables `extString` and `extData`:

```
#define BUFSIZE 256
char extString[BUFSIZE];
double extData[9];
```

Use these variables to read values from a file or a subroutine available from your product. This example uses initialization to create the external data:

```
const char *extString = "Data from External Device";
double extData[9] = { 1.0, 4.0, 7.0, 2.0, 5.0, 8.0, 3.0, 6.0, 9.0 };
```

Create mxArray Variables

The MAT-File Library uses pointers of type mxArray to reference MATLAB data. The following statements declare pVarNum and pVarChar as pointers to an array of any size or type:

```
/*Pointer to the mxArray to read variable extData */  
mxArray *pVarNum;  
/*Pointer to the mxArray to read variable extString */  
mxArray *pVarChar;
```

To create a variable of the proper size and type, select one of the mxCreate* functions from the MX Matrix Library.

The size of extData is 9, which the example copies into a 3-by-3 matrix. Use the mxCreateDoubleMatrix function to create a two-dimensional, double-precision, floating-point mxArray initialized to 0.

```
pVarNum = mxCreateDoubleMatrix(3,3,mxREAL);
```

Use the mxCreateString function to create an mxArray variable for extString:

```
pVarChar = mxCreateString(extString);
```

Create MATLAB Variable Names

matimport.c assigns variable names inputArray and titleString to the mxArray data. Use these names in the MATLAB workspace. For more information, see “View the Contents of a MAT-File”.

```
const char *myDouble = "inputArray";  
const char *myString = "titleString";
```

Read External Data into mxArray Data

Copy data from the external source into each mxArray.

The C memcpy function copies blocks of memory. This function requires pointers to the variables extData and pVarNum. The pointer to extData is (void *)extData. To get a pointer to pVarNum, use one of the mxGet* functions from the MX Matrix Library. Since the data contains only real values of type double, this example uses the mxGetPr function:

```
memcpy((void *) (mxGetPr(pVarNum)), (void *) extData, sizeof(extData));
```

The following statement initializes the `pVarChar` variable with the contents of `extString`:

```
pVarChar = mxCreateString(extString);
```

Variables `pVarNum` and `pVarChar` now contain the external data.

Create and Open MAT-File

The `matOpen` function creates a handle to a file of type `MATFile`. The following statements create a file pointer `pmat`, name the file `matimport.mat`, and open it for writing:

```
MATFile *pmat;  
const char *myFile = "matimport.mat";  
pmat = matOpen(myFile, "w");
```

Write mxArray Data to File

The `matPutVariable` function writes the `mxArray` and variable name into the file:

```
status = matPutVariable(pmat, myDouble, pVarNum);  
status = matPutVariable(pmat, myString, pVarChar);
```

Clean Up

To close the file:

```
matClose(pmat);
```

To free memory:

```
mxDestroyArray(pVarNum);  
mxDestroyArray(pVarChar);
```

Build the Application

To build the application, use the `mex` function with the appropriate `MAT` options file. For more information, see “Compiling and Linking MAT-File Programs” on page 1-22.

For example, to use the Microsoft Visual C++® Version 8.0 compiler, select it as described in “Selecting a Compiler on Windows Platforms” on page 3-28. The options file for this compiler is `msvc80engmatopts.bat`. Use the following MATLAB commands to build `matimport`:

```
% Create full path name for options file
optionsfile = fullfile(matlabroot, ...
    'bin', 'win32', 'mexopts', 'msvc80engmatopts.bat');
mex('-v', '-f', optionsfile, 'matimport.c')
```

Create the MAT-File

Run `matimport` to create the file `matimport.mat`. Either invoke the program from the system command prompt, or at the MATLAB command prompt, type:

```
!matimport
```

Import Data into MATLAB

Any user with a compatible version of MATLAB can read the `matimport.mat` file. Start MATLAB and use the `load` command to import the data into the workspace:

```
load matimport.mat
```

To see the variables, type `whos`; MATLAB displays:

Name	Size	Bytes	Class
<code>inputArray</code>	3x3	72	double
<code>titleString</code>	1x43	86	char

Create MAT-File in C

The `matcreat.c` example illustrates how to use the library routines to create a MAT-file that you can load into the MATLAB workspace. The program also demonstrates how to check the return values of MAT-function calls for read or write failures. To see the code, open the file in MATLAB Editor.

To produce an executable version of this program, compile the file and link it with the appropriate library. For details on platform specifics, see “Compiling and Linking MAT-File Programs” on page 1-22.

After compiling and linking your MAT-file program, you can run the standalone application you just produced. This program creates `mattest.mat`, a MAT-file that you can load into MATLAB. To run the application, depending on your platform, either double-click its icon or enter `matcreat` at the system prompt:

```
matcreat
Creating file mattest.mat...
```

To verify the MAT-file, at the command prompt, type:

```
whos -file mattest.mat
```

Name	Size	Bytes	Class
GlobalDouble	3x3	72	double array (global)
LocalDouble	3x3	72	double array
LocalString	1x43	86	char array

```
Grand total is 61 elements using 230 bytes
```

Create MAT-File in C++

There is a C++ version of `matcreat.c` in the `matlabroot\extern\examples\eng_mat` folder. To see `matcreat.cpp`, open the file in MATLAB Editor.

Read MAT-File in C/C++

The `matdgn.c` example illustrates how to use the library routines to read and diagnose a MAT-file. To see the code, open the file in MATLAB Editor.

After compiling and linking this program, you can view its results:

```
matdgn mattest.mat
Reading file mattest.mat...
```

```
Directory of mattest.mat:
GlobalDouble
LocalString
LocalDouble
```

```
Examining the header for each variable:
According to its header, array GlobalDouble has 2 dimensions
  and was a global variable when saved
According to its header, array LocalString has 2 dimensions
  and was a local variable when saved
According to its header, array LocalDouble has 2 dimensions
  and was a local variable when saved
```

```
Reading in the actual array contents:
According to its contents, array GlobalDouble has 2 dimensions
  and was a global variable when saved
According to its contents, array LocalString has 2 dimensions
  and was a local variable when saved
According to its contents, array LocalDouble has 2 dimensions
  and was a local variable when saved
Done
```

Create MAT-File in Fortran

The `matdemo1.F` example creates the MAT-file, `matdemo.mat`. To see the code, you can open the file in MATLAB Editor.

After compiling and linking your MAT-file program, you can run the standalone application you just produced. This program creates a MAT-file, `matdemo.mat`, that you can load into MATLAB. To run the application, depending on your platform, either double-click its icon or enter `matdemo1` at the system prompt:

```
matdemo1
Creating MAT-file matdemo.mat ...
Done creating MAT-file
```

To verify the MAT-file, at the command prompt, enter:

```
whos -file matdemo.mat
Name          Size          Bytes  Class

Numeric       3x3             72  double array
String        1x33            66  char array

Grand total is 42 elements using 138 bytes
```

Note For an example of a Microsoft Windows standalone program (not MAT-file specific), see `engwindemo.c` in the `matlabroot\extern\examples\eng_mat` folder.

Read MAT-File in Fortran

The `matdemo2.F` example illustrates how to use the library routines to read the MAT-file created by `matdemo1.F` and describe its contents. To see the code, open the file in MATLAB Editor.

After compiling and linking this program, you can view its results:

```
matdemo2
Directory of Mat-file:
String
Numeric
Getting full array contents:
  1
Retrieved String
  With size  1-by- 33
  3
Retrieved Numeric
  With size  3-by-  3
```

Work with mxArray

In this section...
“Read Structures from a MAT-File” on page 1-18
“Read Cell Arrays from a MAT-File” on page 1-19

The MAT-File Interface Library lets you access MATLAB arrays (type `mxArray`) in a MAT-file. To work directly with an `mxArray` in a C/C++ or Fortran application, use functions in the MX Matrix Library. The options files already link to this library, as described in “What You Need” on page 1-3.

You can find examples for working with `mxArrays` in the `matlabroot/extern/examples/mex` and `matlabroot/extern/examples/mx` folders. The following topics show C code examples, based on these MEX examples, for working with cells and structures. The examples show how to read cell and structure arrays and display information based on the type of the `mxArray` within each array element.

If you create an application from one of the MEX examples, here are some tips for adapting the code to a standalone application.

- The MAT-file example, `matdgn.c`, shows how to open and read a MAT-file. For more information about the example, see “Read MAT-File in C/C++” on page 1-15.
- The MEX example, `explore.c`, has functions to read any MATLAB type using the `mxClassID` function. For more information about the example, see “Using Data Types” on page 3-23.
- Some MEX examples use functions, such as `mexPrintf`, from the MEX Library `libmex`. (For a complete list of the C functions, see “Build C/C++ MEX-Files”.) You do not need to use these functions to work with an `mxArray`, but if your program calls any of them, you must link to the MEX Library. To do this, modify your options file to add `libmex.lib` to the link statement.

Read Structures from a MAT-File

The `matreadstructarray.c` example is based on the `analyze_structure` function in `explore.c`. For simplicity this example only processes real

elements of type `double`; refer to the `explore.c` example for error checking and processing other types.

To see the code, open the file in the MATLAB Editor.

After compiling and linking your MAT-file program, you can run the standalone application on the following MAT-file, `testpatient.mat`. Create a structure, `patient`, and save it:

```
patient(1).name = 'John Doe';
patient(1).billing = 127.00;
patient(1).test = [79 75 73; 180 178 177.5; 172 170 169];
patient(2).name = 'Ann Lane';
patient(2).billing = 28.50;
patient(2).test = [68 70 68; 118 118 119; 172 170 169];

save('testpatient.mat')
```

To calculate the total of the billing field, type:

```
!matreadstruct testpatient.mat patient billing
```

```
Total for billing: 155.50
```

Read Cell Arrays from a MAT-File

The `matreadcellarray.c` example is based on the `analyze_cell` function in `explore.c`.

To see the code, open the file in the MATLAB Editor.

After compiling and linking your MAT-file program, you can run the standalone application on the following MAT-file, `testcells.mat`. Create 3 cell variables and save:

```
cellvar = {'hello'; [2 3 4 6 8 9]; [2; 4; 5]};
structvar = {'cell with a structure'; patient; [2; 4; 5]};
multicellvar = {'cell with a cell'; cellvar; patient};
save('testcells.mat', 'cellvar', 'structvar', 'multicellvar')
```

To display the `mxArray` type for the contents of cell `cellvar`, type:

```
!matreadcell testcells.mat cellvar
```

```
0: string
```

```
1: numeric class
```

```
2: numeric class
```

Table of MAT-File Source Code Files

The *matlabroot/extern/examples/eng_mat* folder contains C/C++ and Fortran source code for examples demonstrating how to use the MAT-file routines. These examples create standalone programs. The source code is the same for both Windows and UNIX systems.

Example	Description
<code>matcreat.c</code>	C program that demonstrates how to use the library routines to create a MAT-file that you can load into MATLAB.
<code>matcreat.cpp</code>	C++ version of the <code>matcreat.c</code> program.
<code>matdgn.c</code>	C program that demonstrates how to use the library routines to read and diagnose a MAT-file.
<code>matdemo1.F</code>	Fortran program that demonstrates how to call the MATLAB MAT-file functions from a Fortran program.
<code>matdemo2.F</code>	Fortran program that demonstrates how to use the library routines to read the MAT-file created by <code>matdemo1.F</code> and describe its contents.
<code>matimport.c</code>	C program based on <code>matcreat.c</code> used in the example for writing standalone applications.
<code>matreadstructure.c</code>	C program based on <code>explore.c</code> to read contents of a structure array.
<code>matreadcellarray.c</code>	C program based on <code>explore.c</code> to read contents of a cell array.

Compiling and Linking MAT-File Programs

In this section...

“Building on UNIX Operating Systems” on page 1-22

“Building on Windows Operating Systems” on page 1-23

“Deploying MAT-File Applications” on page 1-24

Building on UNIX Operating Systems

To build on a UNIX operating system, refer to “Setting Run-Time Library Path” on page 1-22 and “Using the Options File” on page 1-23.

Setting Run-Time Library Path

At run time, you must tell the UNIX operating system where the API shared libraries reside by setting an environment variable. The UNIX command you use and the values you provide depend on your shell and system architecture. The following table lists the name of the environment variable (*envvar*) and the values (*pathspec*) to assign to it. The term *matlabroot* refers to the root folder of your MATLAB installation.

Operating System	<i>envvar</i>	<i>pathspec</i>
64-bit Linux®	LD_LIBRARY_PATH	<i>matlabroot</i> /bin/glnxa64: <i>matlabroot</i> /sys/os/glnxa64
64-bit Apple Macintosh (Intel®)	DYLD_LIBRARY_PATH	<i>matlabroot</i> /bin/maci64: <i>matlabroot</i> /sys/os/maci64

Using the C Shell. Set the library path using the command:

```
setenv envvar pathspec
```

Replace the terms *envvar* and *pathspec* with the appropriate values from the table. For example, on a Macintosh system use:

```
setenv DYLD_LIBRARY_PATH
```

```
matlabroot/bin/maci64:matlabroot/sys/os/maci64
```

You can place these commands in a startup script, such as `~/ .cshrc`.

Using the Bourne Shell. Set the library path using the command:

```
envvar = pathspec:envvar
export envvar
```

Replace the terms *envvar* and *pathspec* with the appropriate values from the table. For example, on a Macintosh system use:

```
DYLD_LIBRARY_PATH=matlabroot/bin/maci64:matlabroot/sys/os/maci64:$DYLD_LIBRARY_PATH
export DYLD_LIBRARY_PATH
```

You can place these commands in a startup script such as `~/ .profile`.

Using the Options File

The MATLAB options file for UNIX systems, `matopts.sh`, lets you use the `mex` script to easily compile and link MAT-file applications. The options file is in `matlabroot/bin`. Use the `-f` switch to specify the name and location of the options file.

For example, to compile and link the `matcreat.c` example, first copy the file to a writable folder, such as `c:\work`, on your path:

```
copyfile(fullfile(matlabroot, 'extern', 'examples', 'eng_mat', ...
    'matcreat.c'), fullfile('c:', 'work'));
```

Use the following command to build it:

```
mex('-v', '-f', [matlabroot '/bin/matopts.sh'], 'matcreat.c')
```

If you need to modify the options file for your particular compiler or platform, use the `-v` switch to view the current compiler and linker settings. Then, make the appropriate changes in a local copy of the `matopts.sh` file.

Building on Windows Operating Systems

To compile and link MAT-file programs, use the `mex` script with a MAT options file. Use the `-f` switch to specify the name and location of the options file.

There are different options files for the supported compilers and operating systems, as shown in the following table.

Operating System	Default Options File
32-bit Windows	<i>matlabroot</i> \bin\win32\mexopts*engmatopts.bat
64-bit Windows	<i>matlabroot</i> \bin\win64\mexopts*engmatopts.bat

The * character in the file name, *engmatopts.bat, represents the compiler type and version. For example, the options file to use with the Microsoft Visual C++ Version 9.0 compiler is *msvc90engmatopts.bat*. To build the *matcreat.c* application with this compiler, first copy the following file to a writable folder, such as *c:\work*, on your path:

```
copyfile(fullfile(matlabroot, 'extern', 'examples', 'eng_mat', ...
    'matcreat.c'), fullfile('c:', 'work'));
```

Use the following command to build it:

```
mex('-v', '-f', [matlabroot ...
    '\bin\win32\mexopts\msvc90engmatopts.bat'], ...
    'matcreat.c');
```

If you need to modify the options file for your particular compiler, use the *-v* switch to view the current compiler and linker settings. Then, make the appropriate changes in a local copy of the options file.

Deploying MAT-File Applications

MATLAB requires the following data and library files for building any MAT-file application. You must also distribute these files along with any MAT-file application that you deploy to another system.

Third-Party Data Files

When building a MAT-file application on your system or deploying a MAT-file application to some other system, make sure that the appropriate Unicode® data file is in the *matlabroot/bin/arch* folder. MATLAB uses this file to support Unicode encoding. For systems that order bytes in a big-endian

manner, use `icudt40b.dat`. For systems that order bytes in a little-endian manner, use `icudt40l.dat`.

For deployed applications, be sure to distribute the `MATLAB_licdata.xml` file from the `matlabroot/bin/` folder, and the `matlabroot/resources/MATLAB/` folder with your standalone program.

Third-Party Libraries

When building a MAT-file application on your system or deploying a MAT-file application to some other system, make sure to install the appropriate libraries in the `matlabroot/bin/arch` folder:

Library File Names by Operating System

Windows	Linux	Macintosh (Intel)
<code>libmat.dll</code>	<code>libmat.so</code>	<code>libmat.dylib</code>
<code>libmx.dll</code>	<code>libmx.so</code>	<code>libmx.dylib</code>

In addition to these libraries, you must have all third-party library files that `libmat` requires. MATLAB uses these additional libraries to support Unicode character encoding and data compression in MAT-files. These library files must reside in the same folder as `libmx`. Determine the libraries using the platform-specific methods described in the following table.

Library Dependency Commands

Windows	Linux	Macintosh
Use “Dependency Walker” on page 1-25	<code>ldd -d libmat.so</code>	<code>otool -L libmat.dylib</code>

Dependency Walker. On Windows systems, to find library dependencies, use the third-party product Dependency Walker. Dependency Walker is a free utility that scans any 32-bit or 64-bit Windows module and builds a hierarchical tree diagram of all dependent modules. For each module found, it lists all the functions that are exported by that module, and which of those functions are called by other modules. Download the Dependency Walker utility from the following Web site:

<http://www.dependencywalker.com/>

See the Technical Support solution 1-2RQL4L at <http://www.mathworks.com/support/solutions/data/1-2RQL4L.html> for information on using the Dependency Walker.

Drag and drop the file *matlabroot/bin/win32/libmat.dll* or *matlabroot/bin/win64/libmat.dll* into Depends window.

Calling C Shared Library Functions from MATLAB

- “Calling Functions in Shared Libraries” on page 2-3
- “Limitations to Shared Library Support” on page 2-9
- “Troubleshooting Shared Library Applications” on page 2-14
- “Module Not Found Error” on page 2-15
- “No Matching Signature Error” on page 2-16
- “MATLAB Crashes Making a Function Call to a Shared Library” on page 2-17
- “Passing Arguments to Shared Library Functions” on page 2-18
- “Shared Library shrlibsample.c” on page 2-23
- “Pass String Arguments” on page 2-25
- “Pass Structures” on page 2-27
- “Pass Enumerated Types” on page 2-30
- “Pass Pointers” on page 2-32
- “Pass Arrays” on page 2-33
- “Iterate Through an Array” on page 2-36
- “Working with Pointer Arguments” on page 2-39
- “Working with Structure Arguments” on page 2-53
- “Work with libstruct Objects” on page 2-55
- “MATLAB Prototype Files” on page 2-57

- “Create Alias Function Name Using Prototype File” on page 2-60

Calling Functions in Shared Libraries

In this section...

“What Is a Shared Library?” on page 2-3

“Selecting a C Compiler” on page 2-4

“Loading and Unloading the Library” on page 2-4

“Viewing Library Functions” on page 2-5

“Invoking Library Functions” on page 2-8

What Is a Shared Library?

A shared library is a collection of functions designed to be dynamically loaded by an application at run time. This MATLAB interface supports libraries containing functions programmed in any language, provided the functions have a C interface. MATLAB supports dynamic linking on all supported platforms.

Platform	Shared Library	File Extension
Microsoft Windows	dynamic link library file	.dll
UNIX and Linux	shared object file	.so
Apple Macintosh	dynamic shared library	.dylib

A shared library needs a *header file*, which provides *signatures* for the functions in the library. A function signature, or prototype, establishes the name of the function and the number and types of its parameters. You need to know the full path of the shared library and its header file. You also need to select a C compiler using the `mex -setup` command.

MATLAB accesses C routines built into external, shared libraries through a command-line interface. This interface lets you load an external library into MATLAB memory and access functions in the library. Although types differ between the two language environments, in most cases you can pass types to the C functions without converting. MATLAB does this for you.

Details about using a shared library are in the topics:

- “Selecting a C Compiler” on page 2-4
- “Loading and Unloading the Library” on page 2-4
- “Viewing Library Functions” on page 2-5
- “Invoking Library Functions” on page 2-8

To call a library function, you need to determine the data passed to and from the function. For information about data, see:

- “Passing Arguments to Shared Library Functions” on page 2-18
- “Manually Converting Data Passed to Functions” on page 2-22
- “Working with Pointer Arguments” on page 2-39
- “Working with Structure Arguments” on page 2-53

When you are finished working with the shared library, it is important to unload the library to free memory.

For more information, see “Limitations to Shared Library Support” on page 2-9

Selecting a C Compiler

To select a C/C++ compiler, run the `mex -setup` command before using `loadlibrary`, as described in “Selecting a Compiler on Windows Platforms” on page 3-28 and “Selecting a Compiler on UNIX Platforms” on page 3-33.

Loading and Unloading the Library

To give MATLAB software access to functions in a shared library, you must first load the library into memory. After you load the library, you can request information about library functions and call them directly from the MATLAB command line. When you no longer need the library, unload it from memory to conserve memory usage.

To load a shared library into MATLAB, use the `loadlibrary` function. The most common syntax for the `loadlibrary` function is:

```
loadlibrary('shrlib', 'hfile')
```

where `shrlib` is the shared library file name, and `hfile` is the name of the header file containing the function prototypes. See the `loadlibrary` reference page for variations in the syntax and information on library file extensions.

Note The header file provides signatures for the functions in the library and is a required argument for `loadlibrary`.

For example, you can use `loadlibrary` to load the `libmx` library that defines the MATLAB `mx` routines. The following command creates the full path for the library header file, `matrix.h`:

```
hfile = fullfile(matlabroot,'extern','include','matrix.h');
```

To load the library, type:

```
loadlibrary('libmx',hfile)
```

Use the `unloadlibrary` function to unload the library and free up memory.

Viewing Library Functions

- “Viewing Functions in the Command Window” on page 2-5
- “Viewing Functions in a GUI” on page 2-7
- “Viewing Functions in the Command Window” on page 2-5
- “Viewing Functions in a GUI” on page 2-7

Viewing Functions in the Command Window

Use the `libfunctions` command to display information about a library’s functions in the MATLAB Command Window. For example, to see what functions are available in the `libmx` library, type:

```
if not(libisloaded('libmx'))
    hfile = [matlabroot '\extern\include\matrix.h'];
    loadlibrary('libmx',hfile)
end
```

```
libfunctions libmx
```

MATLAB displays (in part):

Functions in library libmx:

```
mxAddField                mxGetScalar
mxArrayToString           mxGetString_730
mxCalcSingleSubscript_730 mxGetUserBits
mxCalloc                  mxIsCell
mxCreateCellArray_730     mxIsChar
mxCreateCellMatrix_730    mxIsClass
.                          .
.                          .
.                          .
```

To view function signatures, use the `-full` switch. This shows the MATLAB syntax for calling functions written in C. The types used in the argument lists and return values are MATLAB types, not C types. For more information on types, see “C and MATLAB Equivalent Types” on page 2-18. For example, at the command line enter:

```
list = libfunctions('libmx','-full')
```

MATLAB displays (in part):

```
list =
' [int32, MATLAB array, cstring] mxAddField(MATLAB array, cstring) '
' [cstring, MATLAB array] mxArrayToString(MATLAB array) '
' [uint64, MATLAB array, uint64Ptr] mxCalcSingleSubscript_730(MATLAB array,
' lib.pointer mxCalloc(uint64, uint64) '
' [MATLAB array, uint64Ptr] mxCreateCellArray_730(uint64, uint64Ptr) '
' MATLAB array mxCreateCellMatrix_730(uint64, uint64) '
.
.
.
```

Viewing Functions in a GUI

Use the `libfunctionsview` function to get information about functions in a library. MATLAB creates a new window to display the following information:

Heading	Description
Return Type	Types the method returns
Name	Function name
Arguments	Valid types for input arguments

To see the functions in the `libmx` library, type:

```
if not(libisloaded('libmx'))
    hfile = [matlabroot '\extern\include\matrix.h'];
    loadlibrary('libmx',hfile)
end
libfunctionsview libmx
```

MATLAB displays the following window:

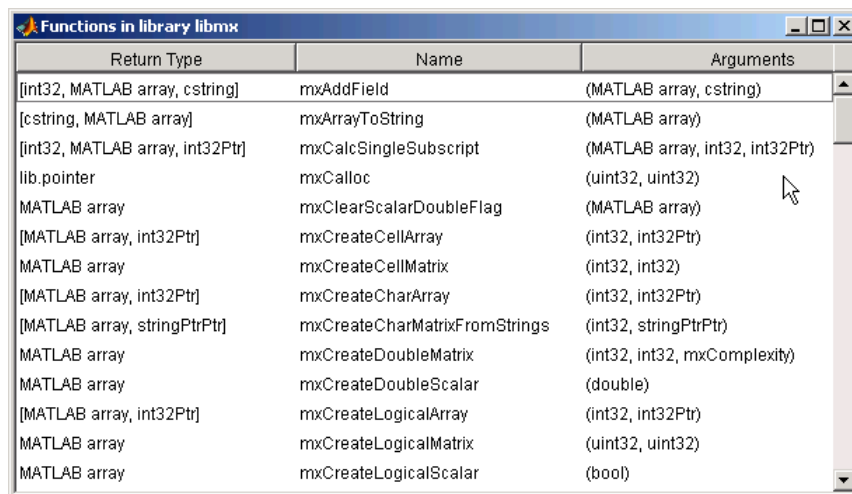

Return Type	Name	Arguments
[int32, MATLAB array, cstring]	<code>mxAddField</code>	(MATLAB array, cstring)
[cstring, MATLAB array]	<code>mxArrayToString</code>	(MATLAB array)
[int32, MATLAB array, int32Ptr]	<code>mxCalcSingleSubscript</code>	(MATLAB array, int32, int32Ptr)
lib.pointer	<code>mxMalloc</code>	(uint32, uint32)
MATLAB array	<code>mxClearScalarDoubleFlag</code>	(MATLAB array)
[MATLAB array, int32Ptr]	<code>mxCreateCellArray</code>	(int32, int32Ptr)
MATLAB array	<code>mxCreateCellMatrix</code>	(int32, int32)
[MATLAB array, int32Ptr]	<code>mxCreateCharArray</code>	(int32, int32Ptr)
[MATLAB array, stringPtrPtr]	<code>mxCreateCharMatrixFromStrings</code>	(int32, stringPtrPtr)
MATLAB array	<code>mxCreateDoubleMatrix</code>	(int32, int32, mxComplexity)
MATLAB array	<code>mxCreateDoubleScalar</code>	(double)
[MATLAB array, int32Ptr]	<code>mxCreateLogicalArray</code>	(int32, int32Ptr)
MATLAB array	<code>mxCreateLogicalMatrix</code>	(uint32, uint32)
MATLAB array	<code>mxCreateLogicalScalar</code>	(bool)

The types used in the argument lists and return values are MATLAB types, not C types. For more information on types, see “C and MATLAB Equivalent Types” on page 2-18.

Invoking Library Functions

After loading a shared library into the MATLAB workspace, use the `calllib` function to call functions in the library. The syntax for `calllib` is:

```
calllib('libname','funcname',arg1,...,argN)
```

You need to specify the library name, function name, and any arguments that get passed to the function.

The following example calls functions from the `libmx` library. To load the library, type:

```
if not(libisloaded('libmx'))
    hfile = [matlabroot '\extern\include\matrix.h'];
    loadlibrary('libmx',hfile);
end
```

To create an array `y`, type:

```
y = rand(4,7,2);
```

To get information about `y`, type:

```
calllib('libmx','mxGetNumberOfElements',y)
```

```
ans =
    56
```

MATLAB displays the number of elements in the array.

Type:

```
calllib('libmx','mxGetClassID',y)
```

```
ans =
    mxDOUBLE_CLASS
```

MATLAB displays the class of the array.

For information on how to define the argument types, see “Passing Arguments to Shared Library Functions” on page 2-18.

Limitations to Shared Library Support

In this section...

“MATLAB Supports C Library Routines” on page 2-9

“Workarounds for Loading C++ Libraries” on page 2-9

“Using Bit Fields” on page 2-10

“Using Enum Declarations” on page 2-11

“Unions Not Supported” on page 2-11

“Compiler Dependencies” on page 2-12

“Limitations Using Structures” on page 2-12

“Limitations Using Pointers” on page 2-12

“Functions with Variable Number of Input Arguments Not Supported”
on page 2-13

MATLAB Supports C Library Routines

The MATLAB shared library interface supports C library routines only. Most professionally-written libraries designed to be used by multiple languages and platforms work fine. Many homegrown libraries or libraries that have only been tested from C++ have interfaces that are not usable and require modification or an interface layer. In this case, we recommend using MEX-files, as described in “C/C++ Source MEX-Files” on page 4-2.

Workarounds for Loading C++ Libraries

The shared library interface does not support C++ classes or overloaded functions elements. However, you can apply one of the following methods to load a C++ library using `loadlibrary`.

Declare Functions as extern C

For example, the following function prototype from the file `shrlibsample.h` shows the syntax to use for each function:

```
#ifdef __cplusplus
extern "C" {
```

```
#endif
void addMixedTypes(
    short  x,
    int    y,
    double z
);

/* other prototypes may be here */

#ifdef __cplusplus
}
#endif
```

The following C++ code is not legal C code for the header file:

```
extern "C" void addMixedTypes(short x,int y,double z);
```

Add Module Definition File in Visual Studio

While building the DLL from C++ code in Microsoft Visual Studio®, add a Module Definition File (.DEF) in the project. At a minimum, the DEF file must contain the following module-definition statements:

- The first statement in the file must be the `LIBRARY` statement.
- The `EXPORTS` statement lists the names and, optionally, the ordinal values of the functions exported by the DLL.

For example, if a DLL exports functions `multDoubleArray` and `addMixedTypes`, `module.def` contains:

```
LIBRARY
EXPORTS
multDoubleArray
addMixedTypes
```

Using Bit Fields

You can modify a bit field declaration by using type `int` or an equivalent. For example, if your library has the following declared in its header file:

```
int myfunction();
```

```

struct mystructure
{
    /* note the sum of fields bits */
    unsigned field1 :4;
    unsigned field2 :4;
};

```

you can replace it with:

```

int myfunction();

struct mystructure
{
    /* field 8 bits wide to be manipulated in MATLAB */
    char allfields; /* A char is 8 bits on all supported platforms */
};

```

It is then possible to access the data in the two fields using bit masking in MATLAB.

Using Enum Declarations

char definitions for enum are not supported. In C a char constant `A' for instance is automatically converted to its numeric equivalent (65) but MATLAB does not do this so the header file must be modified first replacing `A' with the number 65 (`int8(`A') == 65`). For example, replace:

```
enum Enum1 {ValA='A',ValB='B'};
```

with:

```
enum Enum1 {ValA=65,ValB=66};
```

Unions Not Supported

Unions are not supported. It may be possible to modify the source code taking out the union declaration and replacing it with the largest alternative, then writing MATLAB code to interpret the results as needed. For example, replace the following union:

```
struct mystruct
```

```
{
    union
    {
        struct {char byte1,byte2;};
        short word;
    };
};
```

with:

```
struct mystruct
{
    short word;
};
```

where on a little-endian based machine, `byte1` is `mod(f,256)`, `byte2` is `f/256`, and `word=byte2*256+byte1`.

Compiler Dependencies

Header files must be compatible with the supported compilers on a platform. For an up-to-date list of supported compilers, see the [Supported and Compatible Compilers Web page](#). You cannot load external libraries with explicit dependencies on other compilers.

Limitations Using Structures

Nested structures or structures containing a pointer to a structure are not supported. However, MATLAB can access an array of structures created in an external library.

Limitations Using Pointers

Function Pointers

The shared library interface does not support library functions that work with function pointers.

Multilevel Pointers

Limited support for multilevel pointers and structures containing pointers. Using inputs and outputs and structure members declared with more than two levels of indirection is unsupported. For example, `double ***outp` translated to `doublePtrPtrPtr` is not supported.

Functions with Variable Number of Input Arguments Not Supported

The shared library interface does not support library functions with variable number of arguments, which are represented by an ellipsis (...).

You can create multiple alias functions in a prototype file, one for each set of arguments used to call the function. For more information, see “MATLAB Prototype Files” on page 2-57.

Troubleshooting Shared Library Applications

Module Not Found Error

This error occurs when the shared library has dependencies which MATLAB can not find.

On Windows systems, to find library dependencies, use the third-party product Dependency Walker. Dependency Walker is a free utility that scans any 32-bit or 64-bit Windows module and builds a hierarchical tree diagram of all dependent modules. For each module found, it lists all the functions that are exported by that module, and which of those functions are called by other modules. Download the Dependency Walker utility from the following Web site:

<http://www.dependencywalker.com/>

See the Technical Support solution 1-2RQL4L at <http://www.mathworks.com/support/solutions/data/1-2RQL4L.html> for information on using the Dependency Walker.

No Matching Signature Error

This error occurs when you call a function without the correct input arguments, or if there is an error in the function signature in the header file.

For example, the function signature for the `addStructByRef` function in `shrlibsample` is:

```
[double, c_structPtr] addStructByRef(c_structPtr)
```

Load the library.

```
addpath(fullfile(matlabroot,'extern','examples','shrlib'))  
loadlibrary('shrlibsample')
```

Create a structure, and call `addStructByRef`.

```
struct.p1 = 4; struct.p2 = 7.3; struct.p3 = -290;
```

If you call the function without the input argument, MATLAB displays the error message.

```
[res,st] = calllib('shrlibsample','addStructByRef');
```

```
Error using calllib  
No method with matching signature.
```

The correct call is:

```
[res,st] = calllib('shrlibsample','addStructByRef',struct);
```

MATLAB Crashes Making a Function Call to a Shared Library

Some shared libraries, compiled as Microsoft Windows 32-bit libraries, use a calling convention that is incompatible with the default MATLAB calling convention. The default calling convention for MATLAB and for Microsoft C and C++ compilers is `cdecl`. For more information, see the MSDN® Calling Conventions article.

If your library uses a different calling convention, you must create a `loadlibrary` prototype file and modify it with the correct settings, as described in the Technical Support solution 1-671ZZL at <http://www.mathworks.com/support/solutions/data/1-671ZZL.html>.

For information about creating prototype files, see “MATLAB Prototype Files” on page 2-57.

Passing Arguments to Shared Library Functions

In this section...
“C and MATLAB Equivalent Types” on page 2-18
“Passing Arguments” on page 2-20
“Passing a NULL Pointer” on page 2-21
“Manually Converting Data Passed to Functions” on page 2-22

C and MATLAB Equivalent Types

The shared library interface supports all standard scalar C types. The following table shows these C types with their equivalent MATLAB types. MATLAB uses the type from the right column for arguments having the C type shown in the left column.

Note All scalar values returned by MATLAB are of type double.

MATLAB Primitive Types

C Type	Equivalent MATLAB Type
char, byte	int8
unsigned char, byte	uint8
short	int16
unsigned short	uint16
int	int32
long (Windows)	int32, long
long (Linux)	int64, long
unsigned int	uint32

MATLAB Primitive Types (Continued)

C Type	Equivalent MATLAB Type
unsigned long (Windows)	uint32, long
unsigned long (Linux)	uint64, long
float	single
double	double
char *	1xn char array
*char[]	cell array of strings

The following table shows how MATLAB maps C pointers (column 1) to the equivalent MATLAB function signature (column 2). In most cases, you can pass a variable from the Equivalent MATLAB Type column to functions with the corresponding Argument Data Type. See “Pointer Arguments in C Functions” on page 2-39 for information about when you might choose to use a `libpointer` object instead.

MATLAB Extended Types

C Pointer Type	Argument Data Type	Equivalent MATLAB Type
double *	doublePtr	double
float *	singlePtr	single
integer pointer types (int *)	(u)int(size)Ptr	(u)int(size)
Matrix of signed bytes	int8Ptr	int8
Null-terminated string passed by value	cstring	1xn char array
Array of pointers to strings (or one **char)	stringPtrPtr	cell array of strings
enum	enumPtr	

MATLAB Extended Types (Continued)

C Pointer Type	Argument Data Type	Equivalent MATLAB Type
<i>type **</i>	Same as <i>typePtr</i> with an added <i>Ptr</i> (for example, <i>double **</i> is <i>doublePtrPtr</i>)	libpointer object
<i>void *</i>	<i>voidPtr</i>	
<i>void **</i>	<i>voidPtrPtr</i>	libpointer object
C-style structure	<i>structure</i>	MATLAB struct
<i>mxArray *</i>	MATLAB array	MATLAB array
<i>mxArray **</i>	MATLAB arrayPtr	libpointer object

Passing Arguments

Here are some important things to note about the input and output arguments shown in the Functions in library shrlibsample listing:

- Many arguments (like `int32` and `double`) are similar to their C counterparts. In these cases, you need only to pass in the MATLAB types shown for these arguments.
- Some C arguments (for example, `**double`, or predefined structures), are different from standard MATLAB types. In these cases, you can either pass a standard MATLAB type and let MATLAB convert it for you, or you convert the data yourself using the MATLAB functions `libstruct` and `libpointer`. For more information, see “Manually Converting Data Passed to Functions” on page 2-22.
- C functions often return data in input arguments passed by reference. MATLAB creates additional output arguments to return these values. Note that in the listing in the previous section, all input arguments ending in `Ptr` or `PtrPtr` are also listed as outputs.

Guidelines for Passing Arguments

- Nonscalar arguments must be declared as passed by reference in the library functions.
- If the library function uses single subscript indexing to reference a two-dimensional matrix, keep in mind that C programs process matrices row by row while MATLAB processes matrices by column. To get C behavior from the function, transpose the input matrix before calling the function, and then transpose the function output.
- Use an empty array, [], to pass a NULL parameter to a library function that supports optional input arguments. This is valid only when the argument is declared as a Ptr or PtrPtr as shown by `libfunctions` or `libfunctionsview`.

Passing a NULL Pointer

You can create a NULL pointer to pass to library functions in the following ways:

- Pass an empty array [] as the argument.
- Use the `libpointer` function:

```
p = libpointer; % no arguments  
  
p = libpointer('string') % string argument  
  
p = libpointer('stringPtr') % pointer to a string argument
```
- Use the `libstruct` function:

```
p = libstruct('structtype'); % structure type
```

Creating an Empty libstruct Object

To create an empty `libstruct` object, call `libstruct` with only the `structtype` argument. For example:

```
sci = libstruct('c_struct')  
get(sci)  
  
p1: 0
```

```
p2: 0  
p3: 0
```

MATLAB displays the initialized values.

Manually Converting Data Passed to Functions

Under most conditions, MATLAB software automatically converts data passed to and from external library functions to the type expected by the external function. However, you may choose to convert your argument data manually. Circumstances under which you might find this advantageous are:

- When you pass the same piece of data to a series of library functions, you can convert it once manually before the call to the first function rather than having MATLAB convert it automatically on every call. This reduces the number of unnecessary copy and conversion operations.
- When you pass large structures, you can save memory by creating MATLAB structures that match the shape of the C structures used in the external function instead of using generic MATLAB structures. The `libstruct` function creates a MATLAB structure modeled from a C structure taken from the library. See “Working with Structure Arguments” on page 2-53 for more information.
- When an argument to an external function uses more than one level of referencing (e.g., `double **`), you must pass a pointer created using the `libpointer` function rather than relying on MATLAB to convert the type automatically.

Shared Library shrlibsample.c

MATLAB software includes a sample external library called `shrlibsample.c`. The library is in the folder `matlabroot\extern\examples\shrlib`. To see the code, open the file in MATLAB Editor. The corresponding header file is `shrlibsample.h`. To see the code, open this file.

To use the `shrlibsample` library, you first need to either add this folder to your MATLAB path with the command:

```
addpath(fullfile(matlabroot,'extern','examples','shrlib'))
```

or make the folder your current working folder with the command:

```
cd(fullfile(matlabroot,'extern','examples','shrlib'))
```

The following code loads the library and displays the MATLAB syntax for calling functions in the library:

```
loadlibrary('shrlibsample')
```

```
libfunctions shrlibsample -full
```

Functions in shrlibsample Library

Functions in library `shrlibsample`:

```
[double, doublePtr] addDoubleRef(double, doublePtr, double)
double addMixedTypes(int16, int32, double)
[double, c_structPtr] addStructByRef(c_structPtr)
double addStructFields(c_struct)
c_structPtrPtr allocateStruct(c_structPtrPtr)
voidPtr deallocateStruct(voidPtr)
lib.pointer exportedDoubleValue
lib.pointer getListOfStrings
doublePtr multDoubleArray(doublePtr, int32)
[lib.pointer, doublePtr] multDoubleRef(doublePtr)
int16Ptr multiplyShort(int16Ptr, int32)
doublePtr print2darray(doublePtr, int32)
printExportedDoubleValue
cstring readEnum(Enum1)
```

```
[cstring, cstring] stringToUpper(cstring)
```

Pass String Arguments

For arguments that require `char *`, you can pass a MATLAB string (a character array). For example, see the `stringToUpper` function in the `shrlibsample` library.

stringToUpper C Function

```
EXPORTED_FUNCTION char* stringToUpper(char *input)
{
    char *p = input;

    if (p != NULL)
        while (*p!=0)
            *p++ = toupper(*p);
    return input;
}
```

`libfunctions` shows that you can use a MATLAB `cstring` for this input.
Type:

```
libfunctions shrlibsample -full
```

stringToUpper Function Signature

Return Type	Name	Arguments
[cstring, cstring]	stringToUpper	(cstring)

Create a MATLAB character array, `str`, and pass it as the input argument:

```
str = 'This was a Mixed Case string';
calllib('shrlibsample', 'stringToUpper', str)
```

```
ans =
    THIS WAS A MIXED CASE STRING
```

Although the input argument that MATLAB passes to `stringToUpper` resembles a pointer to type `char`, it is not a true pointer data type because it does not contain the address of the MATLAB character array, `str`. When the

function executes, it returns the correct result, but does not modify the value in `str`. If you examine `str`, you find it is unchanged. Type:

```
str
```

```
str =  
    This was a Mixed Case string
```

Pass Structures

In this section...

“Add Values of Fields in Structure” on page 2-27

“Preconvert MATLAB Structure Before Adding Values” on page 2-28

“Display Structure Field Names” on page 2-29

Add Values of Fields in Structure

This example sums the values of the fields in a MATLAB structure by calling the `addStructFields` function. The function is in `shrlibsample.c`, described in “Shared Library `shrlibsample.c`” on page 2-23.

Read the function signature.

addStructFields Function Signature

Return Type	Name	Arguments
double	<code>addStructFields</code>	(<code>struct c_struct st</code>)

The input argument is a structure of type `c_struct`.

Look at the definition in the `shrlibsample.h` header file for information about how to create the structure.

c_struct Structure Definition

```
struct c_struct {
    double p1;
    short p2;
    long p3;
};
```

Create and initialize structure `sm`:

```
sm.p1 = 476;    sm.p2 = -299;    sm.p3 = 1000;
```

Each field is of type `double`.

Load the library.

```
if not(libisloaded('shrlibsample'))
    addpath(fullfile(matlabroot,'extern','examples','shrlib'));
    loadlibrary('shrlibsample')
end
```

Call the function.

```
calllib('shrlibsample','addStructFields',sm)

ans =
    1177
```

MATLAB automatically converts the fields of structure `sm` to the library definition for `c_struct`.

Preconvert MATLAB Structure Before Adding Values

This example preconverts structure `sm` to `c_struct` before calling `addStructFields`. For more information about when to preconvert, see “Strategies for Passing Structures” on page 2-53.

Create and initialize structure `sm`:

```
sm.p1 = 476;    sm.p2 = -299;    sm.p3 = 1000;
```

Convert the fields, which are of type `double`, to match the `c_struct` structure type.

```
if (libisloaded('shrlibsample'))
    sc = libstruct('c_struct',sm);
end
```

The fields of `libstruct` object `sc` are `double`, `short`, and `long`.

Call the function.

```
calllib('shrlibsample','addStructFields',sm)

ans =
    1177
```

Display Structure Field Names

This example displays the field names of the externally-defined structure `c_struct`.

Create a `libstruct` object.

```
if (libisloaded('shrlibsample'))  
    s = libstruct('c_struct');  
end
```

To get the names of the fields, type:

```
get(s)
```

```
p1: 0  
p2: 0  
p3: 0
```

MATLAB displays the field names `p1`, `p2`, and `p3` and their values.

Pass Enumerated Types

In this section...

“Call readEnum Function with Enumeration String” on page 2-30

“Call Function with Integer Equivalent of Enumeration” on page 2-30

“Call Function with enum Pointer Type” on page 2-31

Call readEnum Function with Enumeration String

In MATLAB, you can express an enumerated type as either the enumeration string or its equivalent numeric value. The `readEnum` function from the `shrlibsample` library displays a string that matches the input argument.

Read the function signature.

readEnum Function Signature

Return Type	Name	Arguments
cstring	readEnum	(Enum1)

Look at the definition in the `shrlibsample.h` header file for information about the values for the `Enum1` input.

Enum1 enum Definition

```
typedef enum Enum1 {en1 = 1, en2, en4 = 4} TEnum1;
```

Call `readEnum` with a string:

```
calllib('shrlibsample', 'readEnum', 'en4')
```

```
ans =  
    You chose en4
```

Call Function with Integer Equivalent of Enumeration

The `Enum1` definition declares enumeration `en4` equal to 4. Call `readEnum` with the numeric argument.

```
calllib('shrlibsample', 'readEnum', 4)
```

```
ans =
    You chose en4
```

Call Function with enum Pointer Type

MATLAB maps C function enumeration pointer arguments to *enumPtr*, where *enum* is the name of a C enumeration. The `GetEnumType` function uses the `Enum1` definition from `shrlibsample.h` to ...

Read the function signature.

GetEnumType Function Signature

Return Type	Name	Arguments
void	GetEnumType	(Enum1Ptr)

Create an `Enum1Ptr`.

```
enumValueIn = libpointer('Enum1Ptr', 4);
```

Call the function.

```
[retVal enumValueOut] = calllib(...
    'shrlibsample',
    'GetEnumType',
    enumValueIn);
```

Read the value.

```
get(enumValueIn)
```

Pass Pointers

Pass Primitive MATLAB Type

MATLAB automatically converts an argument passed by value into an argument passed by reference when the external function prototype defines the argument as a pointer. For example, a MATLAB `double` argument passed to a function that expects `double *` is converted to a `double pointer` by MATLAB.

`addDoubleRef` is a C function that takes an argument of type `double *`.

addDoubleRef C Function

```
EXPORTED_FUNCTION double addDoubleRef(double x, double *y, double z)
{
    return (x + *y + z);
}
```

Call the function with three arguments of type `double`, and MATLAB handles the conversion:

```
calllib('shrlibsample', 'addDoubleRef', 1.78, 5.42, 13.3)
```

```
ans =
    20.5000
```

Pass Arrays

In this section...

“Two Dimensional MATLAB Arrays” on page 2-33

“More than Two Dimensional MATLAB Arrays” on page 2-34

Two Dimensional MATLAB Arrays

All MATLAB data is stored columnwise, and MATLAB uses one-based indexing for subscripts. MATLAB uses these conventions because it was originally written in Fortran. To demonstrate how this may affect your MATLAB data when using C functions, create the following matrix:

```
m=1:12;
m=reshape(m,4,3)
dims = size(m)
```

```
m =
     1     5     9
     2     6    10
     3     7    11
     4     8    12
```

```
dims =
     4     3
```

Matrix `m` is a 4-by-3 array.

You might need to transpose MATLAB arrays before passing them to a C function since C assumes a row by column format. The `print2darray` function in the `shrlibsample` library shows this.

`print2darray` C Function

```
EXPORTED_FUNCTION void print2darray(double my2d[][3],int len)
{
    int indxi,indxj;
    for(indxi=0;indxi<len;++indxi)
    {
```

```
        for(indxj=0;indxj<3;++indxj)
        {
            mexPrintf("%10g",my2d[indxi][indxj]);
        }
        mexPrintf("\n");
    }
}
```

The first argument is a two dimensional array. The len argument is the number of rows. The function displays each element of the matrix. Using matrix `m`:

```
calllib('shrlibsample','print2darray',m,4)
```

```
1         2         3
4         5         6
7         8         9
10        11        12
```

You must transpose `m` to get the desired result:

```
calllib('shrlibsample','print2darray',m',4)
```

```
1         5         9
2         6        10
3         7        11
4         8        12
```

More than Two Dimensional MATLAB Arrays

When passing an array having more than two dimensions, the shape of the array might be altered by MATLAB. To ensure that the array retains its shape, store the size of the array before making the call, and then use this same size to reshape the output array to the correct dimensions. For example:

```
vs = size(vin)           % Store the original dimensions
vs =
    2     5     2

vout = calllib('shrlibsample','multDoubleArray',vin,20);

size(vout)              % Dimensions have been altered
```

```
ans =  
    2    10  
  
vout = reshape(vout,vs);    % Restore the array to 2-by-5-by-2  
  
size(vout)  
ans =  
    2    5    2
```

Iterate Through an Array

In this section...

“Create Cell Array from libpointer” on page 2-36

“Perform Pointer Arithmetic on Structure Array” on page 2-37

Create Cell Array from libpointer

This example creates a MATLAB cell array of strings, `mlStringArray`, from the output of the `getListOfStrings` function.

The `getListOfStrings` function creates an array of strings and returns a pointer to the array.

```
if not(libisloaded('shrlibsample'))
    addpath(fullfile(matlabroot,'extern','examples','shrlib'));
    loadlibrary('shrlibsample')
end
```

Call the function.

```
ptr = calllib('shrlibsample','getListOfStrings')
```

```
ptr =
```

```
libpointer
```

Create indexing variables to iterate through the arrays. Use `ptrindex` for the strings returned by the function and `index` for the MATLAB array:

```
ptrindex = ptr;
index = 1;
```

Create the cell array of strings, `mlStringArray`:

```
while ischar(ptrindex.value{1}) %stop at end of list (NULL)
    mlStringArray{index} = ptrindex.value{1};
    ptrindex = ptrindex + 1; %increment pointer
    index = index + 1; %increment array index
end
```

To view the contents of the cell array, type:

```
m1StringArray
m1StringArray =
    'String 1'    'String Two'    ''    'Last string'
```

Perform Pointer Arithmetic on Structure Array

This example creates a MATLAB structure, based on the `c_struct` definition in the `shrlibsample.h` header file. It uses pointer arithmetic to access elements of the structure.

Load the definition.

```
if not(libisloaded('shrlibsample'))
    addpath(fullfile(matlabroot,'extern','examples','shrlib'));
    loadlibrary('shrlibsample')
end
```

Create the MATLAB structure.

```
s = struct('p1',{1,2,3},'p2',{1.1,2.2,3.3},'p3',{0});
```

Create a pointer to the structure.

```
sptr = libpointer('c_struct',s);
```

Read the values of the first element.

```
v1 = sptr.Value;
```

To read the values of the next element, increment the pointer.

```
sptr = sptr + 1;
```

```
v2 = sptr.Value;
```

Working with Pointer Arguments

In this section...

“Pointer Arguments in C Functions” on page 2-39

“The libpointer Object” on page 2-39

“Creating a Pointer to a Primitive Type” on page 2-41

“Creating a Pointer to a Structure” on page 2-44

“Passing a Pointer to the First Element of an Array” on page 2-46

“Putting a String into a Void Pointer” on page 2-47

“Passing an Array of Strings” on page 2-47

“Memory Allocation for an External Library” on page 2-49

“Multilevel Pointers” on page 2-50

Pointer Arguments in C Functions

Many functions in external libraries pass arguments by reference. When you pass by reference, you pass a *pointer* to the value. In the function signature, these are the arguments with names ending in `Ptr` and `PtrPtr`. Although MATLAB does not support passing by reference, you can create a MATLAB argument, called a *libpointer object*, that is compatible with a C pointer.

In many cases, you can simply pass a MATLAB variable (passing an argument by value), even when the signature for that function declares the argument to be a pointer. There are times, however, when it is useful to pass a *libpointer*.

- You want to modify the data in the input arguments.
- You are passing large amounts of data, and you don't want to make copies of the data.
- The library stores and uses the pointer for a period of time so you want the MATLAB function to control the lifetime of the *libpointer* object.

The libpointer Object

A *libpointer* is an instance of a MATLAB `lib.pointer` class.

Properties of `lib.pointer` Class

- Value
- `DataType` — see the `libpointer` function.

Methods of `lib.pointer` Class

- `disp`
- `isNull`
- `plus`. For an example, see “Creating a Pointer by Offsetting from an Existing `libpointer`” on page 2-43.
- `reshape`. For an example, see “Guidelines for Passing Arguments” on page 2-21.
- `setdatatype`. For more information, see “Reading a `libpointer` Object” on page 2-40 and the example in “Reading Function Return Values” on page 2-42.

Constructing a `libpointer` Object

To construct a pointer, use the `libpointer` function. For example, you want to create a pointer, `pv`, to a value of type `int16`. In this case, the type of the pointer is the data type (`int16`) suffixed by the letters `Ptr`:

```
pv = libpointer('int16Ptr',485);
```

To display the properties of the variable `pv`, type:

```
get(pv)
```

```
Value: 485  
DataType: 'int16Ptr'
```

Reading a `libpointer` Object

When a library function returns a `libpointer` object, you must initialize its type and size using the `setdatatype` method. The function signature for `setdatatype` is:

Name	Arguments
setdatatype	(handle, string, double)

where `handle` is the object's handle, `string` is the type, and `double` is the size. For an example, see “Reading Function Return Values” on page 2-42.

Creating a Pointer to a Primitive Type

The following example illustrates how to construct and pass a pointer, and how to interpret the output. It uses the `multDoubleRef` function in the `shrlibsampl` library, which multiplies the input by 5. The input is a pointer to a double, and it returns a pointer to a double.

multDoubleRef C Function

```
EXPORTED_FUNCTION double *multDoubleRef(double *x)
{
    *x *= 5;
    return x;
}
```

Construct a `libpointer` object, `xp`, to point to the input data, `x`.

```
x = 15;
xp = libpointer('doublePtr',x);
```

Verify the contents of `xp`:

```
get(xp)
```

```
Value: 15
DataType: 'doublePtr'
```

Now call the function and check the results:

```
calllib('shrlibsampl', 'multDoubleRef', xp);
xp.Value
```

```
ans =  
    75
```

The object `xp` is a *handle object*. All copies of this handle refer to the same underlying object and any operations you perform on a handle object affect all copies of that object. However, object `xp` is not a C language pointer. Although it points to `x`, it does not contain the address of `x`. The function modifies the `Value` property of `xp` but does not modify the value in the underlying object `x`. The original value of `x` is unchanged. Type:

```
x
```

```
x =  
    15
```

Reading Function Return Values

In the previous example, the result of the function called from MATLAB could be obtained by examining the modified input pointer. But this function also returns data in its output arguments that may be useful.

To see the MATLAB signature for `multDoubleRef`, type:

```
libfunctions shrlibsample -full
```

multDoubleRef Function Signature

Return Type	Name	Arguments
[lib.pointer, doublePtr]	multDoubleRef	(doublePtr)

The function returns two outputs—a `libpointer` object and the `Value` property of the input argument:

Run the example again:

```
x = 15;  
xp = libpointer('doublePtr',x);
```

Check the output values:

```
[xobj,xval] = calllib('shrlibsampl','multDoubleRef',xp)

xobj =
    lib.pointer
xval =
    75
```

Like the input argument `xp`, `xobj` is also a `libpointer` object. You can examine this output, but first you need to initialize its type and size because the function does not define these properties. Use the `setdatatype` function defined by class `lib.pointer` to set the data type to `doublePtr` and the size to 1-by-1. Once initialized, you can examine outputs by typing:

```
setdatatype(xobj,'doublePtr',1,1)
get(xobj)

ans =
    Value: 75
    DataType: 'doublePtr'
```

The second output of `multDoubleRef`, `xval`, is a copy of the `Value` property of input `xp`.

Creating a Pointer by Offsetting from an Existing `libpointer`

You can use the plus operator (+) to create a new pointer that is offset from an existing pointer by a scalar numeric value. For example, suppose you create a `libpointer` to the vector `x`:

```
x = 1:10;
xp = libpointer('doublePtr',x);
xp.Value

ans =
    1    2    3    4    5    6    7    8    9   10
```

Use the plus operator to create a new libpointer that is offset from xp:

```
xp2 = xp+4;  
xp2.Value
```

```
ans =  
     5     6     7     8     9    10
```

Note The new pointer (xp2 in this example) is valid only as long as the original pointer, xp, exists.

Creating a Pointer to a Structure

If a function has an input argument that is a pointer to a structure, you can either pass the structure itself, or pass a pointer to the structure. Creating a pointer to a structure is similar to creating a pointer to a primitive type.

The `addStructByRef` function in the `shrlibsample` library takes a pointer to a structure of type `c_struct`. The output argument is the sum of all fields in the structure. The function also modifies the fields of the input structure.

addStructByRef C Function

```
EXPORTED_FUNCTION double addStructByRef(struct c_struct *st) {  
    double t = st->p1 + st->p2 + st->p3;  
    st->p1 = 5.5;  
    st->p2 = 1234;  
    st->p3 = 12345678;  
    return t;  
}
```

Passing the Structure Itself

Although the input to the `addStructByRef` function is a pointer to a structure, you can pass the structure itself and let MATLAB make the conversion to a pointer.

In the following example, create the structure `sm` and call `addStructByRef`:

```
sm.p1 = 476;    sm.p2 = -299;    sm.p3 = 1000;
x = calllib('shrlibsample','addStructByRef',sm)
```

```
x =
    1177
```

However, MATLAB does not modify the contents of `sm`, since it is not a pointer. Type:

```
sm

sm =
    p1: 476
    p2: -299
    p3: 1000
```

Passing a Structure Pointer

The following example passes a pointer to the structure. First, create the `libpointer` object:

```
sp = libpointer('c_struct',sm);
sp.Value
```

```
ans =
    p1: 476
    p2: -299
    p3: 1000
```

The `libpointer`, `sp`, has the same values as the structure `sm`.

Pass the `libpointer` to the function:

```
if not(libisloaded('shrlibsample'))
    addpath(fullfile(matlabroot,'extern','examples','shrlib'));
    loadlibrary('shrlibsample')
end
calllib('shrlibsample','addStructByRef',sp)
```

```
ans =
    1177
```

In this case, the function modifies the structure fields. Type:

```
sp.Value
```

```
ans =  
    p1: 5.5000  
    p2: 1234  
    p3: 12345678
```

MATLAB displays the updated values.

Passing a Pointer to the First Element of an Array

In cases where a function defines an input argument that is a pointer to the first element of a data array, MATLAB automatically passes an argument that is a pointer of the correct type to the first element of data in the MATLAB vector or matrix.

The following **pseudo-code** shows how to do this. Suppose you have a function `mySum` in a library `myLib`. The signature of the C function is:

Return Type	Name	Arguments
int	mySum	(int size, short* data)

The C variable `data` is an array of type `short`. The equivalent MATLAB type is `int16`. You can pass any of the following MATLAB variables to this function:

```
Data = 1:100;  
shortData = int16(Data); %equivalent to C short type  
lp = libpointer('int16Ptr',Data); %libpointer object
```

The following **pseudo-code** statements are equivalent:

```
summed_data = calllib('myLib','mySum',100,Data);  
summed_data = calllib('myLib','mySum',100,shortData);  
summed_data = calllib('myLib','mySum',100,lp);
```

The length of the `data` vector must be equal to the specified `size`. For example:

```
% sum last 50 elements
summed_data = calllib('myLib', 'mySum', 50, Data(51:100));
```

Putting a String into a Void Pointer

C represents characters as eight-bit integers. To use a MATLAB string as an input argument, you must convert the string to the proper type and create a `voidPtr`. To do this, use the `libpointer` function as follows:

```
str = 'string variable';
vp = libpointer('voidPtr', [int8(str) 0]);
```

The syntax `[int8(str) 0]` creates the null-terminated string required by the C function. To read the string, and verify the pointer type, enter:

```
char(vp.Value)
vp.DataType
```

```
ans =
string variable
ans =
voidPtr
```

You can call a function that takes a `voidPtr` to a string as an input argument using the following syntax because MATLAB automatically converts an argument passed by value into an argument passed by reference when the external function prototype defines the argument as a pointer:

```
func_name([int8(str) 0])
```

Note that while MATLAB converts the argument from a value to a pointer, it must be of the correct type.

Passing an Array of Strings

The `getListOfStrings` function from the `shrlibsample` library returns a `char **`, which you can think of as a pointer to an array of strings.

getListOfStrings Function Signature

Return Type	Name
<code>lib.pointer</code>	<code>getListOfStrings</code>

getListOfStrings C Function

```
EXPORTED_FUNCTION const char ** getListOfStrings(void)
{
    static const char *strings[5];
    strings[0]="String 1";
    strings[1]="String Two";
    strings[2]=""; /* empty string */
    strings[3]="Last string";
    strings[4]=NULL;
    return strings;
}
```

To read this array, type:

```
if not(libisloaded('shrlibsample'))
    addpath(fullfile(matlabroot,'extern','examples','shrlib'));
loadlibrary('shrlibsample')
end
ptr = calllib('shrlibsample','getListOfStrings');
```

MATLAB creates a `libpointer` object `ptr` of type `stringPtrPtr`. This object points to the first string. To display the string, use the `Value` property:

```
ptr.Value
```

To view the other strings, you need to increment the pointer. For example, type:

```
for index = 0:3
    tempPtr = ptr + index;
    tempPtr.Value
end
```

```
ans =
    'String 1'
ans =
    'String Two'
ans =
    {''}
ans =
```



```
'Last string'
```

For another example, see “Iterate Through an Array” on page 2-36.

Memory Allocation for an External Library

In general, MATLAB passes a valid memory address each time you pass a variable to a library function. You should use a `libpointer` object in cases where the library stores the pointer and accesses the buffer over a period of time. In these cases, you need to ensure that MATLAB has control over the lifetime of the buffer and to prevent copies of the data from being made. The following **pseudo-code** is an example of asynchronous data acquisition that shows how to use a `libpointer` in this situation.

Suppose an external library `myLib` has the following functions:

```
AcquireData(int points,short *buffer)
IsAcquisitionDone(void)
```

where `buffer` is declared as follows:

```
short buffer[99]
```

First, create a `libpointer` to an array of 99 points:

```
BufferSize = 99;
pBuffer = libpointer('int16Ptr',zeros(BufferSize,1));
```

Then, begin acquiring data and wait in a loop until it is done:

```
calllib('myLib','AcquireData',BufferSize,pbuffer);
while (~calllib('myLib','IsAcquisitionDone')
    pause(0.1)
end
```

The following statement reads the data in the buffer:

```
result = pBuffer.Value;
```

When the library is done with the buffer, clear the MATLAB variable:

```
clear pBuffer
```

Multilevel Pointers

Multilevel pointers are arguments that have more than one level of referencing. A multilevel pointer type in MATLAB uses the suffix `PtrPtr`. For example, use `doublePtrPtr` for the C argument `double **`.

When calling a function that takes a multilevel pointer argument, use a `libpointer` object and let MATLAB convert it to the multilevel pointer. For example, the `allocateStruct` function in the `shrlibsample` library takes a `c_structPtrPtr` argument.

allocateStruct Function Signature

Return Type	Name	Arguments
<code>c_structPtrPtr</code>	<code>allocateStruct</code>	<code>(c_structPtrPtr)</code>

allocateStruct C Function

```
EXPORTED_FUNCTION void allocateStruct(struct c_struct **val)
{
    *val=(struct c_struct*) malloc(sizeof(struct c_struct));
    (*val)->p1 = 12.4;
    (*val)->p2 = 222;
    (*val)->p3 = 333333;
}
```

Create a `libpointer` object of type `c_structPtr` and pass it to the function:

```

if not(libisloaded('shrlibsample'))
    addpath(fullfile(matlabroot,'extern','examples','shrlib'));
    loadlibrary('shrlibsample')
end
sp = libpointer('c_structPtr');
calllib('shrlibsample','allocateStruct',sp)
get(sp)

```

```

ans =
    Value: [1x1 struct]
    DataType: 'c_structPtr'

```

Type:

sp.Value

```

ans =
    p1: 12.4000
    p2: 222
    p3: 333333

```

When you use `allocateStruct`, you must free memory using the command:

```
calllib('shrlibsample','deallocateStruct',sp)
```

Returning an Array of Strings

Suppose you have a library, `myLib`, with a function, `acquireString`, that reads an array of strings. The function signature is:

Return Type	Name	Arguments
char**	acquireString	(void)

```
char** acquireString(void)
```

The following **pseudo-code** shows how to manipulate the return value, an array of pointers to strings.

```
ptr = calllib(myLib,'acquireString');
```

MATLAB creates a `libpointer` object `ptr` of type `stringPtrPtr`. This object points to the first string. To view other strings, you need to increment the pointer. For example, to display the first 3 strings, type:

```
for index = 0:2
    tempPtr = ptr + index;
    tempPtr.Value
end
```

```
ans =
    'str1'
ans =
    'str2'
ans =
    'str3'
```

Working with Structure Arguments

In this section...
“Structure Argument Requirements” on page 2-53
“Finding Structure Field Names” on page 2-53
“Strategies for Passing Structures” on page 2-53

Structure Argument Requirements

When you pass a MATLAB structure to an external library function:

- Every MATLAB field name must match a field name in the library structure definition. Field names are case sensitive.
- MATLAB structures cannot contain fields that are not in the library structure definition.
- If a MATLAB structure contains fewer fields than defined in the library structure, MATLAB sets undefined fields to zero.

You do not need to match the data types of numeric fields. The `calllib` function converts to the correct numeric type.

Finding Structure Field Names

To determine the name and data type of structure fields, you can:

- Consult the library documentation.
- Look at the structure definition in the library header file.
- Use the `libstruct` function. For an example, see “Display Structure Field Names” on page 2-29.

Strategies for Passing Structures

MATLAB automatically converts a structure to the library definition for that structure type. For most cases, such as working with small structures, this works fine. For an example, see “Add Values of Fields in Structure” on page 2-27.

However, when working with repeated calls that pass one or more large structures, it might be to your advantage to convert the structure manually before making any calls to external functions. In this way, you save processing time by converting the structure data only once at the start rather than at each function call. You can also save memory if the fields of the converted structure take up less space than the original MATLAB structure.

To manually convert, call the `libstruct` function to create a *libstruct object*. Although it is an object, it behaves like a MATLAB structure. The fields of the object are derived from an externally-specified structure type. For an example, see “Preconvert MATLAB Structure Before Adding Values” on page 2-28.

Work with libstruct Objects

This example shows the properties and methods of a libstruct object.

Create libstruct Object

Create libstruct object `sc`.

```
sm.p1 = 476;    sm.p2 = -299;    sm.p3 = 1000;
sc = libstruct('c_struct',sm);
```

Class of libstruct Object

A libstruct object is an instance of a MATLAB class called `lib.c_struct`.

`whos`

Name	Size	Bytes	Class
<code>sc</code>	1x1		<code>lib.c_struct</code>
<code>sm</code>	1x1	396	<code>struct array</code>

Size of libstruct Object

Use the `lib.c_struct` class method `structsize` to obtain the size of a libstruct object.

```
sc.structsize
```

```
ans =
    16
```

Accessing Fields of libstruct Object

The fields are properties of the `lib.c_struct` class. You can read and modify a field using the MATLAB `set` and `get` functions:

```
sc = libstruct('c_struct');
set(sc, 'p1', 100, 'p2', 150, 'p3', 200);
get(sc)
```

```
p1: 100  
p2: 150  
p3: 200
```

You can also read and modify the fields by treating them like MATLAB structure fields:

```
sc.p1 = 23;  
sc.p1
```

```
ans =  
23
```

MATLAB Prototype Files

In this section...

- “How to Create a Prototype File” on page 2-58
- “How to Specify a Thunk file” on page 2-58
- “Deploy Applications That Use loadlibrary” on page 2-58
- “Use loadlibrary in a Parallel Computing Environment” on page 2-58
- “Change Function Signature” on page 2-58
- “Rename Library Function” on page 2-58
- “Load Subset of Functions in Library” on page 2-59
- “Call Function with Variable Number of Arguments” on page 2-59

MATLAB provides a way to modify header file information by creating a *prototype file*, a file of MATLAB commands.

Like a header file, the prototype file contains the function signatures for the library. Here are some reasons for using a prototype file.

- To deploy applications that use `loadlibrary` (using MATLAB Compiler™).
- To use `loadlibrary` in a parallel computing environment (using Parallel Computing Toolbox™).
- To make changes to signatures of the library functions.
- To rename some of the library functions.
- To use only a small percentage of the functions in the library you are loading.
- To use functions with a variable number of arguments.

You can make changes to the prototypes by editing the prototype file and reloading the library.

How to Create a Prototype File

To create a prototype file, use the `mfilename` option of the `loadlibrary` function.

How to Specify a Thunk file

For information about default thunk file names, see `loadlibrary`. To change the name, use the `thunkfilename` option.

Deploy Applications That Use `loadlibrary`

To deploy a MATLAB application that uses `loadlibrary`, using MATLAB Compiler:

- Create a prototype file.
- For 64-bit applications, specify a thunk file.
- Include all the relevant files when creating the project with `mcc`.

Use `loadlibrary` in a Parallel Computing Environment

To use `loadlibrary` in a parallel computing environment (using Parallel Computing Toolbox):

- Create a prototype file.
- For 64-bit applications, specify a thunk file.
- Make sure all relevant files are accessible to all workers.

Change Function Signature

Edit the prototype file, changing the `fcns.LHS` or `fcns.RHS` field for that function. This changes the types of arguments on the left hand side or right hand side, respectively.

Rename Library Function

Edit the prototype file, defining the `fcns.alias` field for that function.

Load Subset of Functions in Library

Edit the prototype file, commenting out the unused functions. This reduces the amount of memory required for the library.

Call Function with Variable Number of Arguments

Create an alias function in a prototype file for each set of arguments you use to call the function.

Create Alias Function Name Using Prototype File

This example shows how to create and modify a prototype file to create an alias for the function, `mxGetNumberOfDimensions`.

Use a folder for which you have write-access.

```
cd('c:\work')
```

Create prototype file, `mxproto`.

```
hfile = fullfile(matlabroot,'extern','include','matrix.h');  
loadlibrary('libmx',hfile,'mfilename','mxproto')
```

MATLAB creates the file, `mxproto.m`, in the current folder.

Open the file in MATLAB Editor.

```
edit mxproto.m
```

Search for the function `mxGetNumberOfDimensions`.

The following command assigns the alias `mxGetDims`.

```
fcns.alias{fcnNum}='mxGetDims';
```

Add the command to the line before the command to increment `fcnNum`. The new function prototype, with the new command shown in bold, looks like this:

```
fcns.name{fcnNum}='mxGetNumberOfDimensions';  
fcns.calltype{fcnNum}='cdecl';  
fcns.LHS{fcnNum}='int32';  
fcns.RHS{fcnNum}={'MATLAB array'};  
fcns.alias{fcnNum}='mxGetDims'; % Alias defined  
fcnNum=fcnNum+1; % Increment fcnNum
```

Reload libmx using the prototype file.

```
unloadlibrary libmx  
loadlibrary('libmx', @mxproto)
```

Call the function.

```
y = rand(4,7,2);  
calllib('libmx', 'mxGetDims', y)
```

```
ans =  
     3
```

Clean up.

Intro to MEX-Files

- “Introducing MEX-Files” on page 3-2
- “MEX-Files Call C/C++ and Fortran Programs” on page 3-5
- “MATLAB Data” on page 3-18
- “Build MEX-Files” on page 3-27
- “Table of MEX-File Source Code Files” on page 3-38
- “Custom Building MEX-Files” on page 3-43
- “Call LAPACK and BLAS Functions” on page 3-59
- “Running MEX-Files with .DLL File Extensions on Windows 32-bit Platforms” on page 3-70
- “Upgrade MEX-Files to Use 64-Bit API” on page 3-71
- “Platform Compatibility” on page 3-84
- “Invalid MEX-File Error” on page 3-85
- “Before You Run a MEX-File You Receive from Someone Else” on page 3-86
- “Version Compatibility” on page 3-87
- “Troubleshooting MEX-Files” on page 3-88
- “Configuration Issues” on page 3-89
- “Understanding MEX-File Problems” on page 3-91
- “Compiler- and Platform-Specific Issues” on page 3-96
- “Memory Management Issues” on page 3-97
- “Compiler Errors in Fortran MEX-Files” on page 3-103

Introducing MEX-Files

In this section...
“What Are MEX-Files?” on page 3-2
“Definition of MEX” on page 3-3
“MEX and MX Matrix Libraries” on page 3-3
“Introduction to Source MEX-Files” on page 3-3
“Overview of Creating a Binary MEX-File” on page 3-4
“Configuring Your Environment” on page 3-4

What Are MEX-Files?

You can call your own C, C++, or Fortran subroutines from the MATLAB command line as if they were built-in functions. These programs, called binary *MEX-files*, are dynamically-linked subroutines that the MATLAB interpreter loads and executes. MEX stands for “MATLAB executable.”

Note MATLAB supports MEX-files created in C++, with some limitations. For more information, see “Creating C++ MEX-Files” on page 4-9.

MEX-files have several applications:

- Calling large pre-existing C/C++ and Fortran programs from MATLAB without rewriting them as MATLAB functions
- Replacing performance-critical routines with C/C++ implementations

MATLAB also provides an interface to shared libraries, described in “Calling Functions in Shared Libraries” on page 2-3. You can use the `loadlibrary` and `calllib` commands to call functions in such libraries.

MEX-files are not appropriate for all applications. MATLAB is a high-productivity environment whose specialty is eliminating time-consuming, low-level programming in compiled languages like C, C++, or

Fortran. In general, do your programming in MATLAB. Do not use MEX-files unless your application requires it.

Definition of MEX

The term `mex` has different meanings, as shown in the following table:

MEX Term	Definition
source MEX-file	C, C++, or Fortran source code file.
binary MEX-file	Dynamically-linked subroutine executed in the MATLAB environment.
MEX function library	MATLAB C/C++ and Fortran API Reference library to perform operations in the MATLAB environment.
<code>mex</code> build script	MATLAB function to create a binary file from a source file.

MEX and MX Matrix Libraries

- **MX Matrix Library** — Functions for use in programs to pass `mxArray`, the type MATLAB uses to store arrays, to and from MEX-files. For a list of these functions, see **MX Matrix Library**. For information about `mxArray`, see “MATLAB Data” on page 3-18. For examples using these functions, see `matlabroot/extern/examples/mx`.
- **MEX Library** — Functions to perform operations in the MATLAB environment. For a list of these functions, see “C MEX Library” in “Build C/C++ MEX-Files”. For examples using these functions, see `matlabroot/extern/examples/mex`.

Introduction to Source MEX-Files

This section provides general information about source MEX-files and how to get started. For a C language example, see “Creating a Source MEX-File” on page 3-5. For information about using specific MATLAB C/C++ and Fortran API Reference library functions, see “Workflow of a MEX-File” on page 3-10.

You can create MEX-files in C, C++, or Fortran. For clarity, this topic is in the context of a C language program. For language-specific instructions,

see “C/C++ Source MEX-Files” on page 4-2 and “Fortran Source MEX-Files” on page 5-2.

To create source MEX-files you need the tools and knowledge to modify and build source code. In particular, you need a compiler supported by MATLAB. For an up-to-date list of supported compilers, see the Supported and Compatible Compilers Web page.

A *computational routine* is the source code that performs functionality you want to use with MATLAB. For example, if you created a standalone C program for this functionality, it would have a `main()` function. MATLAB communicates with your MEX-file using a *gateway routine*. The MATLAB function that creates the gateway routine is *mexfunction*. You use `mexfunction` instead of `main()` in your source file.

Overview of Creating a Binary MEX-File

To create a binary MEX-file:

- Assemble your functions and the MATLAB API functions into one or more C/C++ source files.
- Write a gateway function in one of your C/C++ source files.
- Use the MATLAB *mex* function, called a build script, to build a binary MEX-file.
- Use your binary MEX-file like any MATLAB function.

Configuring Your Environment

Before you start building binary MEX-files, select your default compiler and test an existing source MEX-file. For more information about compilers, and for step-by-step instructions for compiling sample programs, see “Build MEX-Files” on page 3-27.

MEX-Files Call C/C++ and Fortran Programs

In this section...

“Creating a Source MEX-File” on page 3-5
“Workflow of a MEX-File” on page 3-10
“Using Binary MEX-Files” on page 3-16
“Binary MEX-File Placement” on page 3-17
“Using Help Files with MEX-Files” on page 3-17
“Workspace for MEX-File Functions” on page 3-17

Creating a Source MEX-File

Suppose you have some C code, called `arrayProduct`, that multiplies an n -dimensional array y by a scalar value x and returns the results in array z . It might look something like the following:

```
void arrayProduct(double x, double *y, double *z, int n)
{
    int i;

    for (i=0; i<n; i++) {
        z[i] = x * y[i];
    }
}
```

If $x = 5$ and y is an array with values 1.5, 2, and 9, then calling:

```
arrayProduct(x,y,z,n)
```

creates an array z with the values 7.5, 10, and 45.

The following steps show how to call this function in MATLAB, using a MATLAB matrix, by creating the MEX-file `arrayProduct`.

- 1 “Create Your MEX Source File” on page 3-6
- 2 “Create a Gateway Routine” on page 3-6

- 3** “Use Preprocessor Macros” on page 3-7
- 4** “Verify Input and Output Parameters” on page 3-7
- 5** “Read Input Data” on page 3-8
- 6** “Prepare Output Data” on page 3-9
- 7** “Perform Calculation” on page 3-9
- 8** “Build the Binary MEX-File” on page 3-9
- 9** “Test the MEX-File” on page 3-9

Create Your MEX Source File

Open MATLAB Editor and copy your code into a new file. Save the file on your MATLAB path, for example, in `c:\work`, and name it `arrayProduct.c`. This file is your computational routine, and the name of your MEX-file is `arrayProduct`.

Copy and paste the code in the following examples to create the final MEX-file. Alternatively, use the example `arrayProduct.c`, located in `matlabroot\extern\examples\mex`. To see the contents of `arrayProduct.c`, open the file in the MATLAB Editor.

Create a Gateway Routine

At the beginning of the file, add the C/C++ header file:

```
#include "mex.h"
```

Add comments:

```
/*  
 * arrayProduct.c  
 * Multiplies an input scalar times a 1xN matrix  
 * and outputs a 1xN matrix  
 *  
 * This is a MEX-file for MATLAB.  
 */
```

After the computational routine, add the gateway routine `mexFunction`:

```
/* The gateway function */
void mexFunction( int nlhs, mxArray *plhs[],
                 int nrhs, const mxArray *prhs[] )
{
/* variable declarations here */

/* code here */
}
```

Use Preprocessor Macros

The MX Matrix Library and MEX Library functions use MATLAB preprocessor macros for cross-platform flexibility.

Edit your computational routine to use `mwSize` for `mxArray` size `n` and index `i`.

```
void arrayProduct(double x, double *y, double *z, mwSize n)
{
    mwSize i;

    for (i=0; i<n; i++) {
        z[i] = x * y[i];
    }
}
```

Verify Input and Output Parameters

In this example, there are two input arguments (a matrix and a scalar) and one output argument (the product). To check that the number of input arguments `nrhs` is two and the number of output arguments `nlhs` is one, put the following code inside the `mexFunction` routine:

```
/* check for proper number of arguments */
if(nrhs!=2) {
    mexErrMsgIdAndTxt("MyToolbox:arrayProduct:nrhs",
                    "Two inputs required.");
}
```

```
if(nlhs!=1) {
    mexErrMsgIdAndTxt("MyToolbox:arrayProduct:nlhs",
        "One output required.");
}
```

The following code validates the input values:

```
/* make sure the first input argument is scalar */
if( !mxIsDouble(prhs[0]) ||
    mxIsComplex(prhs[0]) ||
    mxGetNumberOfElements(prhs[0])!=1 ) {
    mexErrMsgIdAndTxt("MyToolbox:arrayProduct:notScalar",
        "Input multiplier must be a scalar.");
}
```

The second input argument must be a row vector.

```
/* check that number of rows in second input argument is 1 */
if(mxGetM(prhs[1])!=1) {
    mexErrMsgIdAndTxt("MyToolbox:arrayProduct:notRowVector",
        "Input must be a row vector.");
}
```

Read Input Data

Put the following declaration statements at the beginning of your mexFunction:

```
double multiplier;    /* input scalar */
double *inMatrix;    /* 1xN input matrix */
mwSize ncols;        /* size of matrix */
```

Add these statements to the code section of mexFunction:

```
/* get the value of the scalar input */
multiplier = mxGetScalar(prhs[0]);

/* create a pointer to the real data in the input matrix */
inMatrix = mxGetPr(prhs[1]);
```

```
/* get dimensions of the input matrix */
ncols = mxGetN(prhs[1]);
```

Prepare Output Data

Put the following declaration statement after your input variable declarations:

```
double *outMatrix;      /* output matrix */
```

Add these statements to the code section of `mexFunction`:

```
/* create the output matrix */
plhs[0] = mxCreateDoubleMatrix(1,ncols,mxREAL);

/* get a pointer to the real data in the output matrix */
outMatrix = mxGetPr(plhs[0]);
```

Perform Calculation

The following statement executes your function:

```
/* call the computational routine */
arrayProduct(multiplier,inMatrix,outMatrix,ncols);
```

Build the Binary MEX-File

Your source file should look something like `arrayProduct.c`, located in `matlabroot/extern/examples/mex`. To see the contents of `arrayProduct.c`, open the file in the MATLAB Editor.

To build the binary MEX-file, at the MATLAB command prompt, type:

```
mex arrayProduct.c
```

Test the MEX-File

Since the input arguments to `arrayProduct` are of type `double`, you can call the function with default MATLAB variables. Type:

```
s = 5;
A = [1.5, 2, 9];
B = arrayProduct(s,A)
```

```
B =  
    7.5000    10.0000    45.0000
```

It is good practice to validate the type of a MATLAB variable before calling a MEX-file. To do this, check for the specific class of the variable, using the `strcmp` function with the `class` function. The following code tests input variable `inputArg` and, if necessary, converts it to `double`:

```
if strcmp(class(inputArg),'double')  
    % OK to call function  
else  
    % Convert variable to correct type  
    inputArg = double(inputArg);  
end
```

For example:

```
inputArg = int16(A);  
if ~strcmp(class(inputArg),'double')  
    inputArg = double(inputArg);  
end  
B = arrayProduct(s,inputArg)
```

```
B =  
    10    10    45
```

To test error conditions, type:

```
arrayProduct
```

```
Error using arrayProduct  
Two inputs required.
```

Workflow of a MEX-File

This section discusses MATLAB API functions for handling the basic workflow of a MEX-file and uses C language code snippets for illustration. For an example of a complete C program, see “Creating a Source MEX-File” on page 3-5. Unless otherwise specified, in this section the term “MEX-file” refers to a source file.

Some basic programming tasks are:

- “Creating a Gateway Function” on page 3-11
- “Declaring Data Structures” on page 3-11
- “Managing Input and Output Parameters” on page 3-12
- “Validating Inputs” on page 3-12
- “Allocating and Freeing Memory” on page 3-13
- “Manipulating Data” on page 3-14
- “Displaying Messages to the User” on page 3-14
- “Handling Errors” on page 3-15
- “Cleaning Up and Exiting” on page 3-15

Creating a Gateway Function

Use the `mexfunction` function in your C source file as the interface between your code and MATLAB. Place this function after your computational routine and any other functions in your source.

The signature for `mexfunction` is:

```
void  
mexFunction(int nlhs, mxArray *plhs[], ...  
            int nrhs, const mxArray *prhs[]);
```

The keyword `const` means your MEX-file does not modify the input arguments, `prhs`.

Declaring Data Structures

Use type `mxArray` to handle MATLAB arrays. The following statement declares an `mxArray` named `myData`:

```
mxArray *myData;
```

To define the values of `myData`, use one of the `mxCreate*` functions. Some useful array creation routines are `mxCreateNumericArray`,

`mxCreateCellArray`, and `mxCreateCharArray`. For example, the following statement allocates an m -by-1 floating-point `mxArray` initialized to 0:

```
myData = mxCreateDoubleMatrix(m, 1, mxREAL);
```

C/C++ programmers should note that data in a MATLAB array is in column-major order. (For an illustration, see “Data Storage” on page 3-20.) Use the MATLAB `mxGet*` array access routines, described in “Manipulating Data” on page 3-14, to read data from an `mxArray`.

Managing Input and Output Parameters

MATLAB passes data to and from MEX-files in a highly regulated way, described in “Required Parameters” on page 4-3.

Input parameters (found in the `prhs` array) are read-only; do not modify them in your MEX-file. Changing data in an input parameter can produce undesired side effects.

You also must take care when using an input parameter to create output data or any data used locally in your MEX-file. This is because of the way MATLAB handles MEX-file cleanup after processing. For an example, see the troubleshooting topic “Incorrectly Constructing a Cell or Structure `mxArray`” on page 3-98.

If you want to copy an input array into your local `myData` array, call `mxDuplicateArray` to make a copy of the input array before using it. For example:

```
mxArray *myData = mxCreateStructMatrix(1,1,nfields,fnames);  
mxSetField(myData,0,"myFieldName",mxDuplicateArray(prhs[0]));
```

Validating Inputs

Good programming practice requires you to validate inputs to your function. MATLAB provides `mxIs*` routines for this purpose. The `mxIsClass` function is a general-purpose way to test an `mxArray`.

For example, suppose your second input argument (identified by `prhs[1]`) must be a full matrix of real numbers. Use the following statements to check this condition:

```
if(mxIsSparse(prhs[1]) ||
    mxIsComplex(prhs[1]) ||
    mxIsClass(prhs[1], "char")) {
    mexErrMsgTxt("input2 must be full matrix of real values.");
}
```

This example is not an exhaustive check. You can also test for structures, cell arrays, function handles, and MATLAB objects.

Allocating and Freeing Memory

MATLAB performs cleanup of MEX-file variables, as described in “Automatic Cleanup of Temporary Arrays” on page 4-47. However, MathWorks® recommends that MEX-file functions destroy their own temporary arrays and free their own dynamically allocated memory. It is more efficient to perform this cleanup in the source MEX-file than to rely on the automatic mechanism.

MATLAB manages memory and performs its own initialization and cleanup. You must use the MATLAB-provided functions, such as `mxMalloc` and `mxFree`, to manage memory. Do not use the standard C library counterparts; doing so can produce unexpected results, including program termination.

For information on how MATLAB allocates memory for arrays and data structures, see “Memory Allocation”.

Allocate memory for variables that your MEX-file uses. For example, if the first input to your function (`prhs[0]`) is a string, in order to manipulate the string, create a buffer `buf` of size `buflen`. The following statements declare these variables:

```
char *buf;
int buflen;
```

The size of the buffer is dependent on the number of dimensions of your input array and the size of the data in the array. This statement calculates the size of `buflen`:

```
buflen = mxGetN(prhs[0])*sizeof(mxChar)+1;
```

Now we can allocate memory for buf:

```
buf = mxMalloc(buflen);
```

At the end of the program, if you do not return buf as a plhs output parameter (as described in “Cleaning Up and Exiting” on page 3-15), then free its memory as follows:

```
mxFree(buf);
```

Manipulating Data

The mxGet* array access routines get references to the data in an mxArray. Use these routines to modify data in your MEX-file. Each function provides access to specific information in the mxArray. Some useful functions are mxGetData, mxGetPr, mxGetM, and mxGetString. Many of these functions have corresponding mxSet* routines to allow you to modify values in the array.

The following statements read the input string prhs[0] into a C-style string buf:

```
char *buf;  
int buflen;  
int status;  
buflen = mxGetN(prhs[0])*sizeof(mxChar)+1;  
buf = mxMalloc(buflen);  
status = mxGetString(prhs[0], buf, buflen);
```

Displaying Messages to the User

Use the mexPrintf function, as you would a C/C++ printf function, to print a string in the MATLAB Command Window. Use the mexErrMsgIdAndTxt and mexWarnMsgIdAndTxt functions to print error and warning information in the Command Window.

For example, using the variables declared in the previous example, you can print the input string prhs[0] as follows:

```
if (mxGetString(prhs[0], buf, buflen) == 0) {
```

```
    mexPrintf("The input string is: %s\n", buf);
}
```

Handling Errors

The `mexErrMsgIdAndTxt` function prints error information and terminates your binary MEX-file. The `mexWarnMsgIdAndTxt` function prints information, but does not terminate the MEX-file. For example:

```
if (mxIsChar(prhs[0])) {
    if (mxGetString(prhs[0], buf, buflen) == 0) {
        mexPrintf("The input string is: %s\n", buf);
    }
    else {
        mexErrMsgIdAndTxt("MyProg:ConvertString",
            "Could not convert string data.");
        // exit MEX-file
    }
}
else {
    mexWarnMsgIdAndTxt("MyProg:InputString",
        "Input should be a string to print properly.");
}

// continue with processing
```

Cleaning Up and Exiting

As described in “Allocating and Freeing Memory” on page 3-13, destroy any temporary arrays and free any dynamically allocated memory, except if such an `mxArray` is returned in the output argument list, returned by `mexGetVariablePtr`, or used to create a structure. Also, never delete input arguments.

Use `mxFree` to free memory allocated by the `mxMalloc`, `mxMalloc`, or `mxRealloc` functions. Use `mxDestroyArray` to free memory allocated by the `mxCreate*` functions.

Using Binary MEX-Files

Binary MEX-files are subroutines produced from C/C++ or Fortran source code. They behave just like MATLAB scripts and built-in functions. While scripts have a platform-independent extension `.m`, MATLAB identifies MEX-files by platform-specific extensions. The following table lists the platform-specific extensions for MEX-files.

Binary MEX-File Extensions

Platform	Binary MEX-File Extension
Linux (64-bit)	<code>mexa64</code>
Apple Macintosh (64-bit)	<code>mexmaci64</code>
Microsoft Windows (32-bit)	<code>mexw32</code>
Windows (64-bit)	<code>mexw64</code>

You call MEX-files exactly as you call any MATLAB function. For example, on a Windows platform, there is a binary MEX-file called `histc.mexw32` (in the MATLAB toolbox folder `matlabroot\toolbox\matlab\datafun`) that performs a histogram count. The file `histc.m` contains the help text documentation. When you call `histc` from MATLAB, the dispatcher looks through the list of folders on the MATLAB search path. It scans each folder looking for the first occurrence of a file named `histc` with either the corresponding file name extension from the table or `.m`. When it finds one, it loads the file and executes it. Binary MEX-files take precedence over `.m` files when like-named files exist in the same folder. However, help text documentation still reads from the `.m` file.

You cannot use a binary MEX-file on a platform if you compiled it on a different platform. Recompile the source code on the platform for which you want to use the MEX-file.

Binary MEX-File Placement

Put your MEX-files in a folder on the MATLAB path. Alternatively, run MATLAB from the folder containing the MEX-file. MATLAB runs functions in the current working folder before functions on the path.

Use `path` to see the current folders on your path. You can add new folders to the path either by using the `addpath` function, or by selecting **File > SetPath** to edit the path.

If you use a Windows operating system and your binary MEX-files are on a network drive, be aware that file servers do not always report folder and file changes correctly. If you change a MEX-file on a network drive and find that MATLAB does not use the latest changes, you can force MATLAB to look for the correct version of the file by changing folders away from and then back to the folder containing the file.

Using Help Files with MEX-Files

You can document the behavior of your MEX-files by writing a MATLAB script containing comment lines. For information, see “Add Help for Your Program”. The `help` command automatically finds and displays the appropriate text when help is requested and the interpreter finds and executes the corresponding MEX-file when the function is invoked.

Workspace for MEX-File Functions

Unlike MATLAB functions, MEX-file functions (binary MEX-files) do not have their own variable workspace. MEX-file functions operate in the caller’s workspace. `mexEvalString` evaluates the string in the caller’s workspace. In addition, you can use the `mexGetVariable` and `mexPutVariable` routines to get and put variables into the caller’s workspace.

MATLAB Data

In this section...
“The MATLAB Array” on page 3-18
“Lifecycle of mxArray” on page 3-18
“Data Storage” on page 3-20
“MATLAB Types” on page 3-21
“Sparse Matrices” on page 3-23
“Using Data Types” on page 3-23
“Testing for Most-Derived Class” on page 3-25

The MATLAB Array

The MATLAB language works with a single object type: the MATLAB array. All MATLAB variables (including scalars, vectors, matrices, strings, cell arrays, structures, and objects) are stored as MATLAB arrays. In C/C++, the MATLAB array is declared to be of type `mxArray`. The `mxArray` structure contains the following information about the array:

- Its type
- Its dimensions
- The data associated with this array
- If numeric, whether the variable is real or complex
- If sparse, its indices and nonzero maximum elements
- If a structure or object, the number of fields and field names

To access the `mxArray` structure, use the API functions in the MX Matrix Library. These functions allow you to create, read, and query information about the MATLAB data in your MEX-files.

Lifecycle of mxArray

Like MATLAB functions, a MEX-file gateway routine passes MATLAB variables by reference. However, these arguments are C pointers. A *pointer*

to a variable is the *address* (location in memory) of the variable. MATLAB functions handle data storage for you automatically. When passing data to a MEX-file, you use pointers, which follow specific rules for accessing and manipulating variables. For information about working with pointers, refer to a programming reference, such as *The C Programming Language* by Kernighan, B. W., and D. M. Ritchie.

Note Since variables use memory, you need to understand how your MEX-file creates an `mxArray` and your responsibility for releasing (freeing) the memory. This is important to prevent memory leaks. The lifecycle of an `mxArray`—and the rules for managing memory—depends on whether it is an input argument, output argument, or local variable. The function you call to deallocate an `mxArray` depends on the function you used to create it, which is listed in the create function’s MX Matrix Library documentation.

Input Argument `prhs`

An `mxArray` passed to a MEX-file through the `prhs` input parameter exists outside the scope of the MEX-file. Do not free memory for any `mxArray` in the `prhs` parameter. Additionally, `prhs` variables are read-only; do not modify them in your MEX-file.

Output Argument `plhs`

If you create an `mxArray` (allocate memory and create data) for an output argument, the memory and data exist beyond the scope of the MEX-file. Do not free memory on an `mxArray` returned in the `plhs` output parameter.

Local Variable

You allocate memory whenever you use an `mxCreate*` function to create an `mxArray` or when you call the `mxMalloc` and associated functions. After observing the rules for handling input and output arguments, the MEX-file should destroy temporary arrays and free dynamically allocated memory. To deallocate memory, use either `mxDestroyArray` or `mxFree`. Refer to the MX Matrix Library function documentation for information about which function to use.

Data Storage

MATLAB stores data in a column-major (columnwise) numbering scheme, which is how Fortran stores matrices. MATLAB uses this convention because it was originally written in Fortran. MATLAB internally stores data elements from the first column first, then data elements from the second column second, and so on, through the last column.

For example, given the matrix:

```
a=['house'; 'floor'; 'porch']  
a =  
    house  
    floor  
    porch
```

its dimensions are:

```
size(a)  
ans =  
     3     5
```

and its data is stored as:

h	f	p	o	l	o	u	o	r	s	o	c	e	r	h
---	---	---	---	---	---	---	---	---	---	---	---	---	---	---

If a matrix is N-dimensional, MATLAB represents the data in N-major order. For example, consider a three-dimensional array having dimensions 4-by-2-by-3. Although you can visualize the data as:

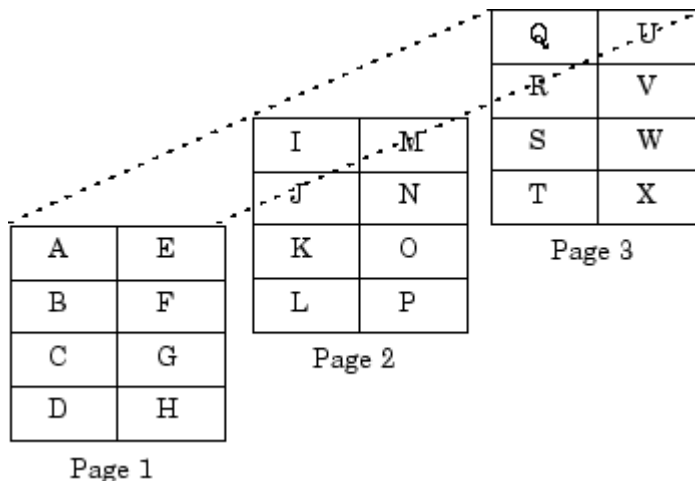

MATLAB internally represents the data for this three-dimensional array in the following order:

A	B	C	D	E	F	G	H	I	J	K	L	M	N	O	P	Q	R	S	T	U	V	W	X
0	1	2	3	4	5	6	7	8	9	10	11	12	13	14	15	16	17	18	19	20	21	22	23

The `mxCalcSingleSubscript` function creates the offset from the first element of an array to the desired element, using N-dimensional subscripting.

MATLAB Types

Complex Double-Precision Matrices

The most common data type in MATLAB is the complex double-precision, nonsparse matrix. These matrices are of type `double` and have dimensions `m`-by-`n`, where `m` is the number of rows and `n` is the number of columns. The data is stored as two vectors of double-precision numbers—one contains the real data and one contains the imaginary data. The pointers to this data are referred to as `pr` (pointer to real data) and `pi` (pointer to imaginary data), respectively. A noncomplex matrix is one whose `pi` is `NULL`.

Numeric Matrices

MATLAB also supports other types of numeric matrices. These are single-precision floating-point and 8-, 16-, and 32-bit integers, both signed and unsigned. The data is stored in two vectors in the same manner as double-precision matrices.

Logical Matrices

The logical data type represents a logical true or false state using the numbers 1 and 0, respectively. Certain MATLAB functions and operators return logical 1 or logical 0 to indicate whether a certain condition was found to be true or not. For example, the statement $(5 * 10) > 40$ returns a logical 1 value.

MATLAB Strings

MATLAB strings are of type char and are stored the same way as unsigned 16-bit integers except there is no imaginary data component. Unlike C, MATLAB strings are not null terminated.

Cell Arrays

Cell arrays are a collection of MATLAB arrays where each mxArray is referred to as a cell. This allows MATLAB arrays of different types to be stored together. Cell arrays are stored in a similar manner to numeric matrices, except the data portion contains a single vector of pointers to mxArrays. Members of this vector are called cells. Each cell can be of any supported data type, even another cell array.

Structures

A 1-by-1 structure is stored in the same manner as a 1-by-n cell array where n is the number of fields in the structure. Members of the data vector are called fields. Each field is associated with a name stored in the mxArray.

Objects

Objects are stored and accessed the same way as structures. In MATLAB, objects are named structures with registered methods. Outside MATLAB, an object is a structure that contains storage for an additional class name that identifies the name of the object.

Multidimensional Arrays

MATLAB arrays of any type can be multidimensional. A vector of integers is stored where each element is the size of the corresponding dimension. The storage of the data is the same as matrices.

Empty Arrays

MATLAB arrays of any type can be empty. An empty `mxAarray` is one with at least one dimension equal to zero. For example, a double-precision `mxAarray` of type `double`, where `m` and `n` equal 0 and `pr` is `NULL`, is an empty array.

Sparse Matrices

Sparse matrices have a different storage convention from that of full matrices in MATLAB. The parameters `pr` and `pi` are still arrays of double-precision numbers, but these arrays contain only nonzero data elements. There are three additional parameters: `nzmax`, `ir`, and `jc`.

- `nzmax` is an integer that contains the length of `ir`, `pr`, and, if it exists, `pi`. It is the maximum possible number of nonzero elements in the sparse matrix.
- `ir` points to an integer array of length `nzmax` containing the row indices of the corresponding elements in `pr` and `pi`.
- `jc` points to an integer array of length `n+1`, where `n` is the number of columns in the sparse matrix. The `jc` array contains column index information. If the `j`th column of the sparse matrix has any nonzero elements, `jc[j]` is the index in `ir` and `pr` (and `pi` if it exists) of the first nonzero element in the `j`th column, and `jc[j+1] - 1` is the index of the last nonzero element in that column. For the `j`th column of the sparse matrix, `jc[j]` is the total number of nonzero elements in all preceding columns. The last element of the `jc` array, `jc[n]`, is equal to `nnz`, the number of nonzero elements in the entire sparse matrix. If `nnz` is less than `nzmax`, more nonzero entries can be inserted into the array without allocating additional storage.

Using Data Types

You can write source MEX-files, MAT-file applications, and engine applications in C/C++ that accept any class or data type supported by MATLAB (see “Data Types”). In Fortran, only the creation of double-precision

n-by-m arrays and strings are supported. You use binary C/C++ and Fortran MEX-files like MATLAB functions.

Caution MATLAB does not check the validity of MATLAB data structures created in C/C++ or Fortran using one of the MX Matrix Library create functions (for example, `mxCreateStructArray`). Using invalid syntax to create a MATLAB data structure can result in unexpected behavior in your C/C++ or Fortran program.

The explore Example

There is an example source MEX-file included with MATLAB, called `explore.c`, that identifies the data type of an input variable. The source code for this example is in `matlabroot/extern/examples/mex`, where `matlabroot` represents the top-level folder where MATLAB is installed on your system.

Note In platform-independent discussions that refer to folder paths, this book uses the UNIX convention. For example, a general reference to the `mex` folder is `matlabroot/extern/examples/mex`.

For example, typing:

```
cd([matlabroot ' /extern/examples/mex']);
x = 2;
explore(x);
```

produces this result:

```
-----
Name: prhs[0]
Dimensions: 1x1
Class Name: double
-----
(1,1) = 2
```

`explore` accepts any data type. Try using `explore` with these examples:

```
explore([1 2 3 4 5])
explore 1 2 3 4 5
explore({1 2 3 4 5})
explore(int8([1 2 3 4 5]))
explore {1 2 3 4 5}
explore(sparse(eye(5)))
explore(struct('name', 'Joe Jones', 'ext', 7332))
explore(1, 2, 3, 4, 5)
```

Testing for Most-Derived Class

If you define functions that require inputs that are:

- MATLAB built-in types
- Not subclasses of MATLAB built-in types

use the following technique to exclude subclasses of built-in types from the input arguments.

- Define a cell array that contains the names of built-in types accepted by your function.
- Call `class` and `strcmp` to test for specific types in a MATLAB control statement.

The following code tests an input argument, `inputArg`:

```
if strcmp(class(inputArg), 'single')
    % Call function
else
    inputArg = single(inputArg);
end
```

Testing for a Category of Types

Suppose you create a MEX-function, `myMexFcn`, that requires two numeric inputs that must be of type `double` or `single`:

```
outArray = myMexFcn(a,b)
```

Define a cell array `floatTypes` that contains the strings `double` and `single`:

```
floatTypes = {'double','single'};

% Test for proper types
if any(strcmp(class(a),floatTypes)) && ...
    any(strcmp(class(b),floatTypes))
    outArray = myMexFcn(a,b);
else
    % Try to convert inputs to avoid error
    ...
end
```

Another Test for Built-In Types

You can use `isobject` to separate built-in types from subclasses of built-in types. The `isobject` function returns `false` for instances of built-in types. For example:

```
% Create a int16 array
a = int16([2,5,7,11]);
isobject(a)
```

```
ans =
     0
```

Determine if an array is one of the built-in integer types:

```
if isa(a,'integer') && ~isobject(a)
    % a is a built-in integer type
    ...
end
```

Build MEX-Files

In this section...

“What You Need to Build MEX-Files” on page 3-27

“Selecting a Compiler on Windows Platforms” on page 3-28

“Selecting a Compiler on UNIX Platforms” on page 3-33

“Linking Multiple Files” on page 3-36

“Overview of Building the timestwo MEX-File” on page 3-36

What You Need to Build MEX-Files

You need a compiler and the `mex` function to build MEX-files. MATLAB software supports many compilers and provides computer configuration files, called *options files*, designed specifically for these compilers. For an up-to-date list of supported compilers, see the Supported and Compatible Compilers Web page.

On 32-bit Microsoft Windows platforms, MATLAB provides a C compiler, `Lcc`. To view Help on using the `Lcc` compiler, type:

```
winopen(fullfile(matlabroot, '\sys\lcc\bin\wedit.hlp'))
```

If you have multiple compilers installed on your system, you can choose which compiler to use, as described in “Selecting a Compiler on Windows Platforms” on page 3-28 or “Selecting a Compiler on UNIX Platforms” on page 3-33.

To help you configure your system using a sample MEX-file, see “Overview of Building the timestwo MEX-File” on page 3-36.

For information about creating MEX-files, see “Creating a Source MEX-File” on page 3-5.

If you have difficulty creating MEX-files, refer to “Troubleshoot MEX-Files”.

Selecting a Compiler on Windows Platforms

A *selected compiler configuration* specifies the compiler and build options MATLAB uses every time you invoke the `mex` build script. The compiler in this configuration is the *selected* compiler. It is the program that compiles source code into object code. A *configuration* is the set of programs and instructions that builds source code into shared libraries and standalone executable files.

To select a configuration, use the `mex -setup` command. You can set or change the configuration anytime, from either the MATLAB or the system command prompt. After you choose a configuration, it becomes the default and you no longer have to select one to compile MEX-files.

You can view information about the selected compiler configuration using the `mex.getCompilerConfigurations` function.

You can change the compiler configuration for a single call to the `mex` script using the `-f` switch, which specifies an options file. Subsequent calls to `mex` continue to use the selected compiler configuration.

For more information about these topics, see:

- “Viewing Supported Windows Compilers” on page 3-28
- “Selecting a Windows Compiler Configuration” on page 3-29
- “Getting Windows Configuration Information” on page 3-31
- “Specifying a Windows Options File” on page 3-32

Viewing Supported Windows Compilers

To see the list of supported compilers on the Windows platform, type:

```
mex -setup
```

MATLAB displays the following dialog. The text has been formatted to fit the page.

Note The list of compilers shown in your version of MATLAB might be different from the list shown in this example. For an up-to-date list of supported compilers, see the Supported and Compatible Compilers Web page.

Please choose your compiler for building external interface (MEX) files:

Would you like mex to locate installed compilers [y]/n? N

Select a compiler:

[1] Intel C++ 9.1 (with Microsoft Visual C++ 2005 linker)
[2] Intel Visual Fortran 10.1 (with Microsoft Visual C++ 2005 linker)
[3] Intel Visual Fortran 9.1 (with Microsoft Visual C++ 2005 linker)
[4] Lcc-win32 C 2.4.1
[5] Microsoft Visual C++ 6.0
[6] Microsoft Visual C++ .NET 2003
[7] Microsoft Visual C++ 2005
[8] Microsoft Visual C++ 2005 Express Edition
[9] Microsoft Visual C++ 2008
[10] Open WATCOM C++
[11] Open WATCOM C++ 1.3

[0] None

Compiler: 0

Done . . .

Selecting a Windows Compiler Configuration

MATLAB helps you choose a compiler configuration by generating a list of either:

- All supported compilers. This is the same information found on the Supported and Compatible Compilers Web page. To see this list, follow the instructions in “Viewing Supported Windows Compilers” on page 3-28.
- Installed compilers found on your system. Only compilers supported by MATLAB are in this list.

To select a configuration from a list of supported compilers found on your system, type:

```
mex -setup
```

MATLAB displays the following dialog. The text has been formatted to fit the page.

Note The list of compilers shown on your system might be different from the list shown in this example. The path names to your compilers might also be different. For an up-to-date list of supported compilers, see the Supported and Compatible Compilers Web page.

```
Please choose your compiler for building external interface (MEX)
files.
```

```
Would you like mex to locate installed compilers [y]/n? y
```

```
Select a compiler:
```

```
[1] Intel Visual Fortran 9.1 (with Microsoft Visual C++ 2005 linker) in
    C:\Program Files\Intel\Compiler\Fortran\9.1
[2] Lcc-win32 C 2.4.1 in C:\PROGRA-1\MATLAB\R2007b\sys\lcc
[3] Microsoft Visual C++ 2005 in
    C:\Program Files\Microsoft Visual Studio 8
```

```
[0] None
```

```
Compiler: 2
```

```
Please verify your choices:
```

```
Compiler: Lcc-win32 C 2.4.1
Location: C:\PROGRA-1\MATLAB\R2007b\sys\lcc
```

```
Are these correct?([y]/n): y
```

```
Trying to update options file:
```

```
C:\WINNT\Profiles\user\Application Data\MathWorks\MATLAB\R2007b\
```

```
mexopts.bat
From template:
C:\PROGRA-1\MATLAB\R2007b\bin\win32\mexopts\lccopts.bat

Done . . .
```

When to Change the Selected Compiler Configuration. On Windows systems, if you create C/C++ and Fortran MEX-files, you must choose the appropriate compiler for the language you are using. If your selected compiler is the wrong language, it generates error messages. To see the language of your selected compiler, type:

```
cc = mex.getCompilerConfigurations;
cc.Language
```

You can change the compiler using either `mex -setup` or by “Specifying a Windows Options File” on page 3-32.

Getting Windows Configuration Information

On Windows systems, there is one compiler configuration. Use the `mex.getCompilerConfigurations` function to find the selected compiler configuration.

To get information about the selected compiler, type:

```
cc = mex.getCompilerConfigurations
```

MATLAB creates a `mex.CompilerConfiguration` object `cc` and displays its properties:

```
cc =

mex.CompilerConfiguration
package: mex

properties:
    Name: 'Microsoft Visual C++ 2005'
    Manufacturer: 'Microsoft'
    Language: 'C++'
    Version: '8.0'
```

```
Location: 'C:\Program Files\Microsoft Visual Studio 8'
Details: [1x1 mex.CompilerConfigurationDetails]
```

list of methods

To see the build options used by the selected compiler, type:

```
ccOptions = cc.Details
```

MATLAB creates a `mex.CompilerConfigurationDetails` object `ccOptions` and displays the options:

```
ccOptions =
```

```
mex.CompilerConfigurationDetails
```

```
package: mex
```

```
properties:
```

```
    CompilerExecutable: 'cl'
```

```
    CompilerFlags: [1x120 char]
```

```
    OptimizationFlags: '/O2 /Oy- /DNDEBUG'
```

```
    DebugFlags: '/Zi /Fd"%OUTDIR%%MEX_NAME%%MEX_EXT%.pdb"'
```

```
    LinkerExecutable: 'link'
```

```
    LinkerFlags: [1x257 char]
```

```
    LinkerOptimizationFlags: ''
```

```
    LinkerDebugFlags: '/DEBUG
```

```
                    /PDB:"%OUTDIR%%MEX_NAME%%MEX_EXT%.pdb"'
```

list of methods

Specifying a Windows Options File

MATLAB includes template options files you can use with particular compilers. The options files are located in the following folders.

Platform	Folder
32-bit Windows	<i>matlabroot</i> \bin\win32\mexopts
64-bit Windows	<i>matlabroot</i> \bin\win64\mexopts

On Windows systems, the options file has a `.bat` file extension.

For information on how to modify options files for particular systems, see “Custom Building MEX-Files” on page 3-43.

Use the `-f` option to specify an options file. To use this option, at the MATLAB prompt, type:

```
mex filename -f optionsfile
```

where *optionsfile* is the full path to the options file.

You might need to specify an options file if you want to use a different compiler (and not use the `-setup` option), or you want to compile MAT or engine standalone programs.

Selecting a Compiler on UNIX Platforms

A *selected compiler configuration* specifies the compiler and build options MATLAB uses every time you invoke the `mex` build script. The compiler in this configuration is the *selected* compiler. It is the program that compiles source code into object code. A *configuration* is the set of programs and instructions that builds source code into shared libraries and standalone executable files.

To select a configuration, use the `mex -setup` command. You can set or change the configuration anytime, from either the MATLAB or the system command prompt. After you choose a configuration, it becomes the default and you no longer have to select one to compile MEX-files.

You can view information about the selected compiler configuration using the `mex.getCompilerConfigurations` function.

You can change the compiler configuration for a single call to the `mex` script using the `-f` switch, which specifies an options file. Subsequent calls to `mex` continue to use the selected compiler configuration.

For more information about these topics, see:

- “Selecting a UNIX Compiler Configuration” on page 3-34
- “Getting UNIX Configuration Information” on page 3-34

- “Specifying a UNIX Options File” on page 3-35

Selecting a UNIX Compiler Configuration

You can set or change your compiler configuration anytime from either the MATLAB command prompt or the UNIX shell, using the command:

```
mex -setup
```

MATLAB generates a list of the available compiler configurations, called options files. To choose a compiler, type the number corresponding to your selection. (If you do not want to change your configuration, type 0. MATLAB returns to the command prompt.) MATLAB displays information about the chosen file.

Getting UNIX Configuration Information

On UNIX systems, there are three configurations, one for each compiler language (C, C++ and Fortran). Use the `mex.getCompilerConfigurations` function to view details about the compiler configurations.

To get information about the compiler configuration, type:

```
cc = mex.getCompilerConfigurations
```

MATLAB creates a `mex.CompilerConfiguration` object `cc` and displays its properties:

```
cc =  
  
1x3 mex.CompilerConfiguration  
package: mex  
  
properties:  
    Name  
  Manufacturer  
    Language  
    Version  
    Location  
    Details
```

list of methods

On the UNIX platform, `cc` is an array of three `CompilerConfiguration` objects – one for each language (C, C++, and Fortran). To see the compiler names, type:

```
disp('Compiler Name')
for i = 1:3; disp(cc(i).Name); end;
```

MATLAB displays information like:

```
Compiler Name
GNU C
GNU C++
g95
```

Note On UNIX systems, `mex.CompilerConfiguration.Location` is an empty string

Specifying a UNIX Options File

MATLAB includes template options files you can use with particular compilers. The options files are located in `matlabroot/bin`.

The UNIX options file is named `*opts.sh`, where `*` is either `mex` or a specific compiler name.

For information on how to modify options files for particular systems, see “Custom Building MEX-Files” on page 3-43.

Use the `-f` option to specify an options file. To use this option, at the MATLAB prompt, type:

```
mex filename -f optionsfile
```

where `optionsfile` is the full path to the options file.

You might need to specify an options file in the following situations:

- You want to use a different compiler (and not use the `-setup` option), or you want to compile MAT or engine standalone programs.
- You do not want to use the system C/C++ compiler.

Linking Multiple Files

You can combine multiple source files, object files, and file libraries to build a binary MEX-file. To do this, list the additional files, with their file extensions, separated by spaces. The name of the MEX-file is the name of the first file in the list.

The following command combines multiple files of different types into a binary MEX-file called `circle.ext`, where `ext` is the extension corresponding to the current platform:

```
mex circle.c square.obj rectangle.c shapes.lib
```

For a Fortran files, type:

```
mex circle.F square.o rectangle.F shapes.o
```

You may find it useful to use a software development tool like MAKE to manage MEX-file projects involving multiple source files. Create a MAKEFILE that contains a rule for producing object files from each of your source files, and then invoke the `mex` build script to combine your object files into a binary MEX-file. This way you can ensure that your source files are recompiled only when necessary.

Overview of Building the `timestwo` MEX-File

MATLAB provides an example MEX-file, `timestwo`, for you to use to configure your system. This function takes a scalar input and doubles it.

The C source file is `timestwo.c`, and the Fortran source file is `timestwo.F`. These files are in `matlabroot\extern\examples\refbook`, where `matlabroot` is the MATLAB root folder, the value returned by the `matlabroot` command.

To work with these files, copy them to a local folder. For example:

```
cd('c:\work')
copyfile([matlabroot '\extern\examples\refbook\timestwo.c'])
copyfile([matlabroot '\extern\examples\refbook\timestwo.F'])
```

To select your compiler, follow the instructions in either “Selecting a Compiler on UNIX Platforms” on page 3-33 or “Selecting a Compiler on Windows Platforms” on page 3-28.

Use the `mex` function to build the binary MEX-file. If you are using a C/C++ compiler, type:

```
mex timestwo.c
```

If you are using a Fortran compiler, type:

```
mex timestwo.F
```

This command creates the file `timestwo.ext`, where `ext` is the value returned by the `mexext` function. You call `timestwo` as if it were a MATLAB function. For example, at the MATLAB command prompt, type:

```
timestwo(4)
```

MATLAB displays:

```
ans =
     8
```

For information about `mex` options, see “MEX Script Switches” on page 3-43.

For information about the large-array-handling API, see “Handling Large `mxArrays`” on page 4-43.

Note In a future version of MATLAB, the default `mex` function will change to use the large-array-handling API. This means the `-largeArrayDims` option will be the default and you must review your MEX-files, as described in “Upgrade MEX-Files to Use 64-Bit API” on page 3-71.

Table of MEX-File Source Code Files

Source code for the MEX examples shown in the following table are in subfolders of *matlabroot/extern/examples*.

To build a C code example, first copy the file to a writable folder, such as *c:\work*, on your path:

```
copyfile(fullfile(matlabroot, 'extern', 'examples', 'foldername', ...
    'filename.c'), fullfile('c:', 'work'));
```

where *filename* is the name of the example and *foldername* is the subfolder name.

Make sure that you have a C/C++ compiler selected using the `mex -setup` command.

You can create and compile MEX-files in MATLAB or at your operating system prompt. MATLAB uses the `mex.m` file. The Microsoft Windows operating system uses the `mex.bat` file, and UNIX uses the `mex.sh` file.

At either prompt, type:

```
mex -v filename.c
```

MEX Examples

Example Name	Example Subfolder	Description
<code>arrayFillGetPr.c</code>	refbook	Fill mxArray using <code>mxGetPr</code>
<code>arrayFillSetData.c</code>	refbook	Fill mxArray with non-double values
<code>arrayFillSetPr.c</code>	refbook	Fill mxArray using <code>mxSetPr</code> to dynamically allocate memory
<code>arrayProduct.c</code>	mex	Multiply a scalar times 1xN matrix

MEX Examples (Continued)

Example Name	Example Subfolder	Description
arraySize.c	mex	Illustrate memory requirements of large mxArray
convec.c convec.F	refbook	Pass complex data
dblmat.F compute.F	refbook	Use of Fortran %VAL
dotProductComplex.c	refbook	Handle Fortran complex return type for function called from a C MEX-file
doubleelement.c	refbook	Use unsigned 16-bit integers
explore.c	mex	Identify data type of input variable
findnz.c	refbook	Use N-dimensional arrays
fulltosparse.c fulltosparse.F loadsparse.F	refbook	Populate a sparse matrix
matrixDivide.c	refbook	Call a LAPACK function
matrixDivideComplex.c	refbook	Call a LAPACK function with complex numbers
matrixMultiply.c	refbook	Call a BLAS function
matsq.F	refbook	Pass matrices in Fortran
matsqint8.F	refbook	Pass non-double matrices in Fortran

MEX Examples (Continued)

Example Name	Example Subfolder	Description
mexatexit.c mexatexit.cpp	mex	Register an exit function to close a data file
mexcallmatlab.c	mex	Call built-in MATLAB disp function
mexcallmatlabwithtrap.mex	mex	How to capture error information
mexcpp.cpp	mex	Illustrate some C++ language features in a MEX-file
mexevalstring.c	mex	Use mexEvalString to assign variables in MATLAB
mexfunction.c	mex	How to use mexfunction
mexget.c	mex	Use mexGet and mexSet to change Color property of a graphics handle
mexgetarray.c	mex	Use mexGetVariable and mexPutVariable to track counters in the MEX-file and in the MATLAB global workspace
mexlock.c mexlockf.F	mex	How to lock and unlock a MEX-file
mxcalcsinglesubscript.mex	mex	Demonstrate MATLAB 1-based matrix indexing versus C 0-based indexing

MEX Examples (Continued)

Example Name	Example Subfolder	Description
mxcreatecellmatrix.c mxcreatecellmatrixf.F	mx	Create 2-D cell array
mxcreatecharmatrixfromstr.c	mx	Create 2-D string array
mxcreatestructarray.c	mx	Create MATLAB structure from C structure
mxgeteps.c mxgetepssf.F	mx	Read MATLAB eps value
mxgetinf.c	mx	Read inf value
mxgetnzmax.c	mx	Display number of nonzero elements in a sparse matrix and maximum number of nonzero elements it can store
mxisclass.c	mx	Check if array is member of specified class
mxisfinite.c	mx	Check for NaN and infinite values
mxislogical.c	mx	Check if workspace variable is logical or global
mxmalloc.c	mx	Allocate memory to copy a MATLAB string to a C string
mxsetdimensions.c mxsetdimensionsf.F	mx	Reshape an array

MEX Examples (Continued)

Example Name	Example Subfolder	Description
mxsetnzmax.c	mx	Reallocate memory for sparse matrix and reset values of pr, pi, ir and nzmax
passstr.F	refbook	Pass C character matrix from Fortran to MATLAB
phonebook.c	refbook	Manipulate structures and cell arrays
revord.c revord.F	refbook	Copy MATLAB string data to and from C-style string
sincall.c sincall.F fill.F	refbook	Create mxArray and pass to MATLAB sin and plot functions
timestwo.c timestwo.F	refbook	Demonstrate common workflow of MEX-file
utdu_slv.c	refbook	Use LAPACK for symmetric indefinite factorization
xtimesy.c xtimesy.F	refbook	Pass multiple parameters
yprime.c yprimef.F yprimefg.F	mex	Solve simple 3 body orbit problem

Custom Building MEX-Files

In this section...
“When to Use Custom Building” on page 3-43
“MEX Script Switches” on page 3-43
“Custom Building on UNIX Systems” on page 3-47
“Custom Building on Windows Systems” on page 3-52

When to Use Custom Building

In general, the defaults that come with MATLAB software should be sufficient for building most binary MEX-files. Following are reasons that you might need more detailed information:

- You want to use an Integrated Development Environment (IDE), rather than the provided script, to build MEX-files.
- You want to create an options file, for example, to use a compiler that is unsupported.
- You want to exercise more control over the build process than the script uses.

The script, in general, uses two stages (or three, for Microsoft Windows platforms) to build MEX-files. These are the compile stage and the link stage. In between these two stages, Windows compilers must perform some additional steps to prepare for linking (the prelink stage).

MEX Script Switches

The `mex` script has a set of switches (also called **options**) that you can use to modify the link and compile stages. The MEX Script Switches table lists the available switches and their uses. Each switch is available on both UNIX and Windows systems unless otherwise noted.

For customizing the build process, you should modify the options file, which contains the compiler-specific flags corresponding to the general compile, prelink, and link steps required on your system. The options file consists of

a series of variable assignments; each variable represents a different logical piece of the build process.

Switch	Function
<code>@rsp_file</code>	(Windows systems only) Include the contents of the text file <code>rsp_file</code> as command-line arguments to <code>mex</code> .
<code>-arch</code>	Build an output file for architecture <code>arch</code> . To determine the value for <code>arch</code> , type <code>computer('arch')</code> at the MATLAB Command Prompt on the target machine. Valid values for <code>arch</code> depend on the architecture of the build platform.
<code>-c</code>	Compile only. Creates an object file, but not a binary MEX-file.
<code>-compatibleArrayDims</code>	Build a binary MEX-file using the MATLAB Version 7.2 array-handling API, which limits arrays to $2^{31}-1$ elements. Default option. (See the <code>-largeArrayDims</code> option.) In verbose mode, if you do not specify either the <code>-largeArrayDims</code> or the <code>-compatibleArrayDims</code> switches, MATLAB displays a message showing the default switch.
<code>-cxx</code>	(UNIX systems only) Use the C++ linker to link the MEX-file if the first source file is in C and there are one or more C++ source or object files. This option overrides the assumption that the first source file in the list determines which linker to use.
<code>-Dname</code>	Define a symbol name to the C preprocessor. Equivalent to a <code>#define name</code> directive in the source. Do not add a space after this switch.

(Continued)

Switch	Function
<code>-Dname=value</code>	Define a symbol name and value to the C preprocessor. Equivalent to a <code>#define name value</code> directive in the source. Do not add a space after this switch.
<code>-f optionsfile</code>	Specify location and name of options file to use. Overrides the mex default-options-file search mechanism.
<code>-fortran</code>	(UNIX systems only) Specify that the gateway routine is in Fortran. This option overrides the assumption that the first source file in the list determines which linker to use.
<code>-g</code>	Create a binary MEX-file containing additional symbolic information for use in debugging. This option disables the mex default behavior of optimizing built object code (see the <code>-O</code> option).
<code>-h[elp]</code>	Print help for mex.
<code>-Ipathname</code>	Add <i>pathname</i> to the list of folders to search for <code>#include</code> files. Do not add a space after this switch.
<code>-inline</code>	This option has been removed.
<code>-lname</code>	Link with object library. On Windows systems, <i>name</i> expands to <i>name.lib</i> or <i>libname.lib</i> and on UNIX systems, to <i>libname.so</i> or <i>libname.dylib</i> . Do not add a space after this switch.

(Continued)

Switch	Function
-L <i>folder</i>	Add <i>folder</i> to the list of folders to search for libraries specified with the -l option. On UNIX systems, you must also set the run-time library path, as explained in “Setting Run-Time Library Path” on page 1-22. Do not add a space after this switch.
-largeArrayDims	Build a binary MEX-file using the MATLAB large-array-handling API. This API can handle arrays with more than $2^{31}-1$ elements. (See the -compatibleArrayDims option.) In verbose mode, if you do not specify either the -largeArrayDims or the -compatibleArrayDims switches, MATLAB displays a message showing the default switch.
-n	No execute mode. Print any commands that mex would otherwise have executed, but do not actually execute any of them.
-O	Optimize the object code. Optimization is enabled by default and by including this option on the command line. If the -g option appears without the -O option, optimization is disabled.
-outdir <i>dirname</i>	Place all output files in folder <i>dirname</i> .
-output <i>resultname</i>	Create binary MEX-file named <i>resultname</i> . Automatically appends the appropriate MEX-file extension. Overrides the default MEX-file naming mechanism.
-setup	Specify the compiler options file to use when calling the mex function. When you use this option, all other command-line options are ignored.

(Continued)

Switch	Function
<code>-Uname</code>	Remove any initial definition of the C preprocessor symbol <i>name</i> . (Inverse of the <code>-D</code> option.) Do not add a space after this switch.
<code>-v</code>	Verbose mode. Print the values for important internal variables after the options file is processed and all command-line arguments are considered. Prints each compile step and final link step fully evaluated.
<code>name=value</code>	Override an options file variable for variable <i>name</i> . For examples, see Override Option Details on mex reference page.

Custom Building on UNIX Systems

On UNIX systems, there are two stages in MEX-file building: compiling and linking.

Compile Stage on UNIX Systems

The compile stage must

- Add `matlabroot/extern/include` to the list of folders in which to find header files (`-Imatlabroot/extern/include`).
- Define the preprocessor macro `MATLAB_MEX_FILE` (`-DMATLAB_MEX_FILE`).
- Compile the source file.

Link Stage on UNIX Systems

The link stage must

- Instruct the linker to build a shared library.

- If you link with your own libraries, set the run-time library path, which is explained in “Setting Run-Time Library Path” on page 1-22.
- Link all objects from compiled source files.
- Export the `mexFunction` symbol, representing function called by MATLAB.

For Fortran MEX-files, the symbols are all lowercase and might have appended underscores. For specific information, invoke the `mex` script in verbose mode and examine the output.

Build Options on UNIX Systems

For customizing the build process, you should modify the options file. The options file contains the compiler-specific flags corresponding to the general steps outlined above. The options file consists of a series of variable assignments. Each variable represents a different logical piece of the build process. The options files provided with MATLAB are located in `matlabroot/bin`. The section “UNIX Default Options File” on page 3-49, describes how the `mex` script looks for an options file.

To aid in providing flexibility, there are two sets of options in the options file that you can turn on and off with switches to the `mex` script. These sets of options correspond to building in *debug mode* and building in *optimization mode*. They are represented by the variables `DEBUGFLAGS` and `OPTIMFLAGS`, respectively, one pair for each *driver* that is invoked (`CDEBUGFLAGS` for the C/C++ compiler, `FDEBUGFLAGS` for the Fortran compiler, and `LDDEBUGFLAGS` for the linker; similarly for the `OPTIMFLAGS`):

- If you build in optimization mode (the default), the `mex` script includes the `OPTIMFLAGS` options in the compile and link stages.
- If you build in debug mode, the `mex` script includes the `DEBUGFLAGS` options in the compile and link stages. It does not include the `OPTIMFLAGS` options.
- You can include both sets of options by specifying both the optimization and debugging flags to the `mex` script (`-O` and `-g`, respectively).

Aside from these special variables, the `mex` options file defines the executable invoked for each mode (C/C++ compile, Fortran compile, link) and the flags for each stage. You also can provide explicit lists of libraries that must be linked in to all MEX-files containing source files of each language.

The variable summary follows.

Variable	C Compiler	C++ Compiler	Fortran Compiler	Linker
Executable	CC	CXX	FC	LD
Flags	CFLAGS	CXXFLAGS	FFLAGS	LDFLAGS
Optimization	COPTIMFLAGS	CXXOPTIMFLAGS	FOPTIMFLAGS	LDOPTIMFLAGS
Debugging	CDEBUGFLAGS	CXXDEBUGFLAGS	FDEBUGFLAGS	LDDEBUGFLAGS
Additional libraries	CLIBS	CXXLIBS	FLIBS	(none)

For specifics on the default settings for these variables, you can

- Examine the options file in *matlabroot/bin/mexopts.sh* (or the options file you are using), or
- Invoke the *mex* script in verbose mode.

UNIX Default Options File

The default MEX options file provided with MATLAB is located in *matlabroot/bin*. The *mex* script searches for an options file called *mexopts.sh* in the following order:

- The location and options file specified with the *mex -f* switch
- The current folder
- The folder specified by *matlabroot/bin*
- The folder returned by the *prefdir* function

mex uses the first occurrence of the options file it finds. If no options file is found, *mex* displays an error message. You can directly specify the name of the options file using the *-f* switch.

The UNIX options file is written in the Bourne shell script language.

For specific information on the default settings for the MATLAB supported compilers, you can examine the options file in `fullfile(matlabroot, 'bin', 'mexopts.sh')`, or you can invoke the `mex` script in verbose mode (`-v`). Verbose mode prints the exact compiler options, prelink commands (if appropriate), and linker options used in the build process for each compiler. “Custom Building on UNIX Systems” on page 3-47 gives an overview of the high-level build process.

Files and Folders on UNIX Systems

This section describes the folder organization and purpose of the files associated with the MATLAB C/C++ and Fortran API Reference on UNIX systems.

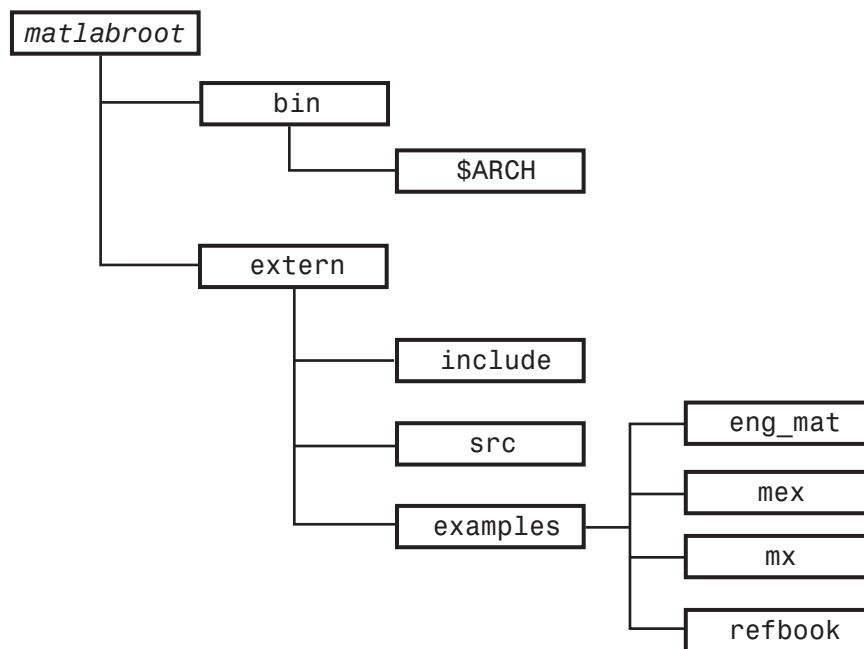

matlabroot/bin. Contains the following files for the MATLAB API:

`mex`

UNIX shell script that creates binary MEX-files from C/C++ or Fortran MEX-file source code.

matlab

UNIX shell script that initializes your environment and then invokes the MATLAB interpreter.

This folder also contains the preconfigured options files that the `mex` script uses with particular compilers. For more information, see “Specifying a UNIX Options File” on page 3-35.

matlabroot/bin/arch. Contains libraries, where *arch* specifies a particular UNIX platform. On some UNIX platforms, this folder contains two versions of this library. Library file names ending with `.so` or `.dylib` are shared libraries.

matlabroot/extern/include. Contains the header files for developing C/C++ and Fortran applications that interface with MATLAB. The relevant header files for the MATLAB API are:

engine.h

C/C++ header file for MATLAB engine programs. Contains function prototypes for engine routines.

mat.h

C/C++ header file for programs accessing MAT-files. Contains function prototypes for `mat` routines.

matrix.h

C/C++ header file containing a definition of the `mxAarray` structure and function prototypes for matrix access routines.

mex.h

Header file for building C/C++ MEX-files. Contains function prototypes for `mex` routines.

fintrf.h

Header file for building Fortran MEX-files. Contains function prototypes for `mex` routines.

matlabroot/extern/src. Contains C source files to support MEX-file features such as argument checking and versioning.

Custom Building on Windows Systems

There are three stages to MEX-file building for both C/C++ and Fortran on Windows systems: compiling, prelinking, and linking.

Compile Stage on Windows Systems

For the compile stage, a mex options file must

- Set up paths to the compiler using the COMPILER (for example, Watcom), PATH, INCLUDE, and LIB environment variables. If your compiler always has the environment variables set (e.g., in AUTOEXEC.BAT), you can comment them out in the options file.
- Define the name of the compiler, using the COMPILER environment variable, if needed.
- Define the compiler switches in the COMPFLAGS environment variable:
 - The switch to create a DLL is required for MEX-files.
 - For standalone programs, the switch to create an exe is required.
 - The -c switch (compile only; do not link) is recommended.
 - The switch to specify 8-byte alignment.
 - You can use any other switch specific to the environment.
- Define preprocessor macro, with -D, MATLAB_MEX_FILE is required.
- Set up optimizer switches and/or debug switches using OPTIMFLAGS and DEBUGFLAGS.
 - If you build in optimization mode (the default), the mex script includes the OPTIMFLAGS option in the compile stage.
 - If you build in debug mode, the mex script includes the DEBUGFLAGS options in the compile stage. It does not include the OPTIMFLAGS option.
 - You can include both sets of options by specifying both the optimization and debugging flags to the mex script (OPTIMFLAGS and DEBUGFLAGS, respectively).

Prelink Stage on Windows Systems

The prelink stage dynamically creates import libraries to import the required function into the MEX, MAT, or engine file:

- All MEX-files link against `libmex.dll` (MEX library).
- MAT standalone programs link against `libmx.dll` (array access library) and `libmat.dll` (MAT-functions).
- Engine standalone programs link against `libmx.dll` (array access library) and `libeng.dll` for engine functions.

Link Stage on Windows Systems

For the link stage, a `mex` options file must

- Define the name of the linker in the `LINKER` environment variable.
- Define the `LINKFLAGS` environment variable that must contain
 - The switch to create a shared library for MEX-files, or the switch to create an `exe` for standalone programs.
 - Export of the entry point to the MEX-file as `mexFunction` for C/C++ or `MEXFUNCTION` for Fortran.
 - The import library (or libraries) created in the `PRELINK_CMDS` stage.
 - You can use any other link switch specific to the compiler.
- Set up the linking optimization and debugging switches `LINKOPTIMFLAGS` and `LINKDEBUGFLAGS`. Use the same conditions described in the “Compile Stage on Windows Systems” on page 3-52.
- Define the link-file identifier in the `LINK_FILE` environment variable, if necessary. For example, Watcom uses `file` to identify that the name following is a file and not a command.
- Define the link-library identifier in the `LINK_LIB` environment variable, if necessary. For example, Watcom uses `library` to identify the name following is a library and not a command.
- Optionally, set up an output identifier and name with the output switch in the `NAME_OUTPUT` environment variable. The environment variable `MEX_NAME` contains the name of the first program in the command line. This

must be set for `-output` to work. If this environment is not set, the compiler default is to use the name of the first program in the command line. Even if this is set, you can override it by specifying the `mex -output` switch.

Linking DLL Files to Binary MEX-Files on Windows Systems

To link a DLL to a MEX-file, list the DLL's `.lib` file on the command line.

Windows Default Options File

The default MEX options file is placed in your `user profile` folder after you configure your system by running `mex -setup`. The `mex` script searches for an options file called `mexopts.bat` in the following order:

- The location and options file specified with the `mex -f` switch
- The current folder
- The user profile folder (returned by the `prefdir` function)

`mex` uses the first occurrence of the options file it finds. If no options file is found, `mex` searches your machine for a supported C/C++ compiler and automatically configures itself to use that compiler. Also, during the configuration process, it copies the compiler's default options file to the `user profile` folder. If multiple compilers are found, you are prompted to select one.

On Windows systems, the options file is written in the Perl script language.

For specific information on the default settings for the MATLAB supported compilers, you can examine the options file, `mexopts.bat`, or you can invoke the `mex` script in verbose mode (`-v`). Verbose mode prints the exact compiler options, prelink commands, if appropriate, and linker options used in the build process for each compiler. "Custom Building on Windows Systems" on page 3-52 gives an overview of the high-level build process.

The User Profile Folder. The Windows user profile folder contains user-specific information such as desktop appearance, recently used files, and **Start** menu items. The `mex` and `mbuild` utilities store their respective options files, `mexopts.bat` and `compopts.bat`, which are created during the `-setup` process, in a folder of your user profile folder, named `Application Data\MathWorks\MATLAB`.

Files and Folders on Windows Systems

This section describes the folder organization and purpose of the files associated with the MATLAB C/C++ and Fortran API Reference on Microsoft Windows systems.

The following figure illustrates the folders in which the MATLAB API files are located. In the illustration, *matlabroot* symbolizes the top-level folder where MATLAB is installed on your system.

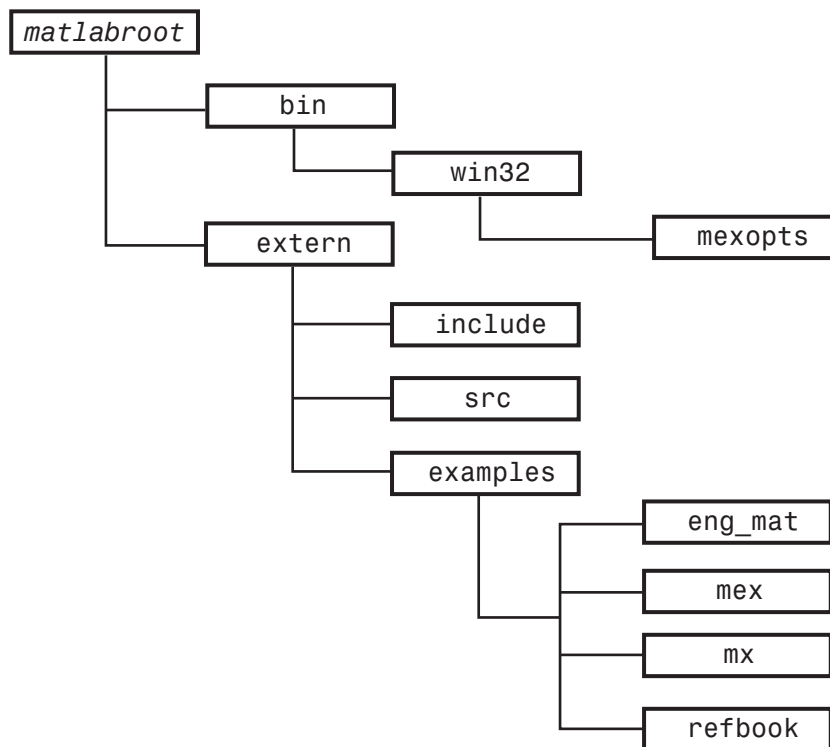

matlabroot\bin. Contains the `mex.bat` batch file that builds C/C++ and Fortran files into binary MEX-files. Also contains `mex.pl`, which is a Perl script used by `mex.bat`.

matlabroot\bin\arch\mexopts. Contains the preconfigured options files that the `mex` script uses with particular compilers. For more information, see “Specifying a Windows Options File” on page 3-32.

matlabroot\extern\include. Contains the header files for developing C/C++ and Fortran applications that interface with MATLAB.

The relevant header files for the MATLAB API (MEX-files, engine, and MAT-files) are

`engine.h`

C/C++ header file for MATLAB engine programs. Contains function prototypes for engine routines.

`mat.h`

C/C++ header file for programs accessing MAT-files. Contains function prototypes for `mat` routines.

`matrix.h`

C/C++ header file containing a definition of the `mxAarray` structure and function prototypes for matrix access routines.

`mex.h`

Header file for building C/C++ MEX-files. Contains function prototypes for `mex` routines.

`fintrf.h`

Header file for building Fortran MEX-files. Contains function prototypes for `mex` routines.

`*.def`

Files used by Microsoft Visual C++ and Microsoft Fortran compilers.

matlabroot \extern\src. Contains files used for debugging MEX-files.

Compiling MEX-Files with the Microsoft Visual C++ IDE

Note This section provides information on how to compile source MEX-files in the Microsoft Visual C++ IDE. It is not totally inclusive. This section assumes that you know how to use the IDE. If you need more information on using the Microsoft Visual C++ IDE, refer to the corresponding Microsoft documentation.

To build MEX-files with the Microsoft Visual C++ integrated development environment:

- 1 Create a project and insert your MEX source files.
- 2 Create a `.def` file to export the MEX entry point. On the **Project** menu, click **Add New Item** and select **Module-Definition File (.def)**. For example:

```
LIBRARY MYFILE
EXPORTS mexFunction          <-- for a C MEX-file
      or
EXPORTS _MEXFUNCTION        <-- for a Fortran MEX-file
```

- 3 On the **Project** menu, click **Properties** for the project to open the property pages.
- 4 Under C/C++ General properties, add the MATLAB include folder, `matlab\extern\include`, as an additional include folder.
- 5 Under C/C++ Preprocessor properties, add `MATLAB_MEX_FILE` as a preprocessor definition.
- 6 Under Linker General properties, change the output file extension to `.mexw32` if you are building for a 32-bit platform or `.mexw64` if you are building for a 64-bit platform.
- 7 Locate the `.lib` files for the compiler you are using under `matlabroot\extern\lib\win32\microsoft` or `matlabroot\extern\lib\win64\microsoft`. Under Linker Input properties, add `libmx.lib`, `libmex.lib`, and `libmat.lib` as additional dependencies.

- 8** Under **Linker Input properties**, add the module definition (`.def`) file you created.
- 9** Under **Linker Debugging properties**, if you intend to debug the MEX-file using the IDE, specify that the build should generate debugging information. For more information about debugging, see “Debugging on the Microsoft Windows Platforms” on page 4-32.

If you are using a compiler other than the Microsoft Visual C++ compiler, the process for building MEX files is like that described above. In step 4, locate the `.lib` files for the compiler you are using in a folder of `matlabroot\extern\lib\win32` or `matlabroot\extern\lib\win64`. For example, if you are using an Open Watcom C/C++ compiler, look in `matlabroot\extern\lib\win32\watcom`.

Call LAPACK and BLAS Functions

In this section...

- “What You Need to Know” on page 3-59
- “Creating a MEX-File Using LAPACK and BLAS Functions” on page 3-60
- “Preserving Input Values from Modification” on page 3-62
- “Passing Arguments to Fortran Functions from C/C++ Programs” on page 3-63
- “Passing Arguments to Fortran Functions from Fortran Programs” on page 3-64
- “Handling Complex Numbers in LAPACK and BLAS Functions” on page 3-65
- “Modifying the Function Name on UNIX Systems” on page 3-69

What You Need to Know

You can call a LAPACK or BLAS function using a MEX-file. To create a MEX-file, you need C/C++ or Fortran programming experience and the software resources (compilers and linkers) to build an executable file. It also is helpful to understand how to use Fortran subroutines. MATLAB provides the `mwlpack` and `mwblas` libraries in `matlabroot/extern/lib`. To work with complex numbers, use the conversion routines in the `fort.c` and `fort.h` files in `matlabroot/extern/examples/refbook`. To help you get started, there are source code examples in `matlabroot/extern/examples/refbook`.

If you do not know how to use MEX-files, start with the following sections:

- “MEX-Files Call C/C++ and Fortran Programs” on page 3-5
- “What You Need to Build MEX-Files” on page 3-27

For an overview showing how to create and build sample MEX-files, start with the following sections:

- “Creating a Source MEX-File” on page 3-5
- “Overview of Building the `timestwo` MEX-File” on page 3-36

Creating a MEX-File Using LAPACK and BLAS Functions

To call LAPACK or BLAS functions:

- 1 Create a source MEX-file containing the `mexFunction` gateway routine, as described in the following topics:
 - “Gateway Routine” on page 4-2 for C/C++ language MEX-files.
 - “Gateway Routine” on page 5-2 for Fortran language MEX-files.
- 2 Select a supported compiler for your platform, as described in the following topics:
 - “Selecting a Compiler on Windows Platforms” on page 3-28
 - “Selecting a Compiler on UNIX Platforms” on page 3-33.
- 3 Build a binary MEX-file using the `mex` command with one or more of the following options:
 - Link your source file to one or both of the libraries, `mwlapack` and `mwblas`.
 - Use the `-largeArrayDims` option; the `mwlapack` and `mwblas` libraries only support 64-bit integers for matrix dimensions.
 - If your function uses complex numbers, build your source file with `fort.c` and include the `fort.h` header file.

The following topics show how to use the `mex` command using the example `matrixMultiply.c`. To work with this file, copy it to a local folder. For example:

```
copyfile(fullfile(matlabroot, 'extern', 'examples', 'refbook', ...  
    'matrixMultiply.c'), fullfile('c:', 'work'));
```

The example files are read-only files. To modify an example, ensure the file is writable by typing:

```
fileattrib('matrixMultiply.c', '+w');
```

Building on Windows Platforms

There are compiler-specific versions of the libraries on the Windows platform. To link to a specific library, look at the *matlabroot/extern/lib/* folder and choose the path for your architecture and compiler. For example, type:

```
cc = mex.getCompilerConfigurations('Any','Selected');
cc.Manufacturer
computer
```

If you selected a Microsoft C/C++ compiler on a 32-bit platform, MATLAB displays:

```
ans =
Microsoft
ans =
PCWIN
```

Link to the libraries in *matlabroot/extern/lib/win32/microsoft/*. To simplify the build command, create variables *lapacklib* and *blaslib*, which identify the full path and file name of each library.

```
lapacklib = fullfile(matlabroot, ...
    'extern', 'lib', 'win32', 'microsoft', 'libmwlapack.lib');
blaslib = fullfile(matlabroot, ...
    'extern', 'lib', 'win32', 'microsoft', 'libmwblas.lib');
```

When you use a variable to identify the library, you must use the function syntax of the *mex* command. (For more information, see “Command vs. Function Syntax”.) To build *matrixMultiply.c*, which uses functions from the BLAS library, type:

```
mex('-v', '-largeArrayDims', 'matrixMultiply.c', blaslib)
```

To build a MEX-file with functions that use complex numbers, see “Handling Complex Numbers in LAPACK and BLAS Functions” on page 3-65.

Building on UNIX Platforms

To build the MEX-file *matrixMultiply.c*, which uses functions from the BLAS library, type:

```
mex -v -largeArrayDims matrixMultiply.c -lmwblas
```

To build a MEX-file with functions that use complex numbers, see “Handling Complex Numbers in LAPACK and BLAS Functions” on page 3-65.

Testing the `matrixMultiply` MEX-File

To run the `matrixMultiply` MEX-file, type:

```
A = [1 3 5; 2 4 7];  
B = [-5 8 11; 3 9 21; 4 0 8];  
X = matrixMultiply(A,B)
```

MATLAB displays:

```
X =  
    24    35   114  
    30    52   162
```

Preserving Input Values from Modification

Many LAPACK and BLAS functions modify the values of arguments passed to them. It is good practice to make a copy of arguments you can modify before passing them to these functions. For information about how MATLAB handles arguments to the `mexFunction`, see “Managing Input and Output Parameters” on page 3-12.

Example — `matrixDivide.c`

The following example calls the LAPACK function `dgesv` that modifies its input arguments. The code in this example makes copies of `prhs[0]` and `prhs[1]`, and passes the copies to `dgesv` to preserve the contents of the input arguments.

To see the example, open the file in the MATLAB Editor. To create the MEX-file, copy the source file to a working folder:

```
copyfile(fullfile(matlabroot, 'extern', 'examples', 'refbook', ...  
    'matrixDivide.c'), fullfile('c:', 'work'));
```

To build the file on Windows, type:

```
lapacklib = fullfile(matlabroot, ...
    'extern', 'lib', 'win32', 'microsoft', 'libmwlpack.lib');
mex('-v', '-largeArrayDims', 'matrixDivide.c', lapacklib)
```

To build the file on UNIX type:

```
mex -v -largeArrayDims matrixDivide.c -lmwlpack
```

To test, type:

```
A = [1 2; 3 4];
B = [5; 6];
X = matrixDivide(A,B)
```

MATLAB displays:

```
X =
   -4.0000
    4.5000
```

Passing Arguments to Fortran Functions from C/C++ Programs

The LAPACK and BLAS functions are written in Fortran. Be aware that C/C++ and Fortran use different conventions for passing arguments to and from functions. Fortran functions expect the arguments to be passed by reference, while arguments to C/C++ functions are passed by value. When you pass by value, you pass a copy of the value. When you pass by reference, you pass a pointer to the value. A reference is also the address of the value.

When you call a Fortran subroutine, like a function from LAPACK or BLAS, from a C/C++ program, be sure to pass the arguments by reference. To do this, precede the argument with an ampersand (&), unless that argument is already a reference. For example, when you create a matrix using the `mxGetPr` function, you create a reference to the matrix and do not need the ampersand before the argument.

In the following code snippet, variables `m`, `n`, `p`, `one`, and `zero` need the `&` character to make them a reference. Variables `A`, `B`, `C`, and `chn` are pointers, which are references.

```
/* pointers to input & output matrices*/
```

```
double *A, *B, *C;
/* matrix dimensions */
mwSignedIndex m,n,p;
/* other inputs to dgemm */
char *chn = "N";
double one = 1.0, zero = 0.0;

/* call BLAS function */
dgemm(chn, chn, &m, &n, &p, &one, A, &m, B, &p, &zero, C, &m);
```

Example – matrixMultiply.c

The `matrixMultiply.c` example calls `dgemm`, passing all arguments by reference. To see the source code, open the file in the MATLAB Editor. To build and run this example, see “Creating a MEX-File Using LAPACK and BLAS Functions” on page 3-60.

Passing Arguments to Fortran Functions from Fortran Programs

You can call LAPACK and BLAS functions from Fortran MEX files. The following example takes two matrices and multiplies them by calling the BLAS routine `dgemm`:

```
#include "fintrf.h"

subroutine mexFunction(nlhs, plhs, nrhs, prhs)
mwPointer plhs(*), prhs(*)
integer nlhs, nrhs
mwPointer mxcreatedoublematrix
mwPointer mxgetpr
mwPointer A, B, C
mwSignedIndex mxgetm, mxgetn
mwSignedIndex m, n, p, numel
double precision one, zero, ar, br
character ch1, ch2

ch1 = 'N'
ch2 = 'N'
```

```
one = 1.0
zero = 0.0

A = mxgetpr(prhs(1))
B = mxgetpr(prhs(2))
m = mxgetm(prhs(1))
p = mxgetn(prhs(1))
n = mxgetn(prhs(2))

plhs(1) = mxcreatedoublematrix(m, n, 0.0)
C = mxgetpr(plhs(1))
numel = 1
call mxcopyprtrtoreal8(A, ar, numel)
call mxcopyprtrtoreal8(B, br, numel)

call dgemm(ch1, ch2, m, n, p, one, %val(A), m,
          +          %val(B), p, zero, %val(C), m)

return
end
```

Handling Complex Numbers in LAPACK and BLAS Functions

MATLAB stores complex numbers differently than Fortran. MATLAB stores the real and imaginary parts of a complex number in separate, equal length vectors, `pr` and `pi`. Fortran stores the same complex number in one location with the real and imaginary parts interleaved.

As a result, complex variables exchanged between MATLAB and a Fortran function are incompatible. Use the conversion routines, `mat2fort` and `fort2mat`, that change the storage format of complex numbers to address this incompatibility.

- `mat2fort` — Convert MATLAB complex matrix to Fortran complex storage.
- `fort2mat` — Convert Fortran complex storage to MATLAB real and imaginary parts.

The `fort.c` and `fort.h` files provide routines for conversion between MATLAB and Fortran complex data structures. These files define the `mat2fort` and `fort2mat` routines.

To use these routines, you need to:

- 1** Include the `fort.h` header file in your source file, using the statement `#include "fort.h"`.
- 2** Link the `fort.c` file with your program. Specify the full path, `matlabroot/extern/examples/refbook` for `fort.c` in the build command.
- 3** Use the `-Ipathname` switch to indicate the header file. Specify the full path, `matlabroot/extern/examples/refbook` for `fort.h` in the build command.
- 4** When you specify the full path, replace the term `matlabroot` with the actual folder name.

Handling Complex Number Input Values

It is unnecessary to copy arguments for functions that use complex number input values. The `mat2fort` conversion routine creates a copy of the arguments for you. For information, see “Preserving Input Values from Modification” on page 3-62.

Handling Complex Number Output Arguments

For complex variables returned by a Fortran function, do the following:

- 1** When allocating storage for the variable, allocate a real variable with twice as much space as you would for a variable of the same size. Do this because the returned variable uses the Fortran format, which takes twice the space. See the allocation of `zout` in the example.
- 2** Use the `fort2mat` function to make the variable compatible with MATLAB.

Example — Passing Complex Variables

This example shows how to call a function, passing complex `prhs[0]` as input and receiving complex `plhs[0]` as output. Temporary variables `zin` and `zout` contain the input and output values in Fortran format. To see the example,

open the file in the MATLAB Editor. To create the MEX-file, copy the source file to a working folder:

```
copyfile(fullfile(matlabroot, 'extern', 'examples', 'refbook', ...
    'matrixDivideComplex.c'), fullfile('c:', 'work'));
```

To build the file on a Windows platform, type:

```
lapacklib = fullfile(matlabroot, ...
    'extern', 'lib', 'win32', 'microsoft', 'libmwlpack.lib');
fortfile = fullfile(matlabroot, 'extern', 'examples', ...
    'refbook', 'fort.c');
fortheadir = fullfile(matlabroot, 'extern', 'examples', ...
    'refbook');
mex('-v', '-largeArrayDims', ['-I' fortheadir], ...
    'matrixDivideComplex.c', fortfile, lapacklib)
```

To build on a UNIX platform, type:

```
fortfile = fullfile(matlabroot, 'extern', 'examples', ...
    'refbook', 'fort.c');
fortheadir = fullfile(matlabroot, 'extern', 'examples', ...
    'refbook');
mex('-v', '-largeArrayDims', ['-I' fortheadir], ...
    'matrixDivideComplex.c', fortfile, '-lmwlapack')
```

To test:

```
Areal = [1 2; 3 4];
Aimag = [1 1; 0 0];
Breal = [5; 6];
Bimag = [0; 0];
Acomplex = complex(Areal,Aimag);
Bcomplex = complex(Breal,Bimag);
X = matrixDivideComplex(Acomplex,Bcomplex)
```

MATLAB displays:

```
X =
  -4.4000 + 0.8000i
   4.8000 - 0.6000i
```

Example — Handling Fortran Complex Return Type

Some level 1 BLAS functions (for example, `zdotu` and `zdotc`) return a double complex type, which the C language does not support. The following C MEX-file, `dotProductComplex.c`, shows how to handle the Fortran complex return type for function `zdotu`. To see the example, open the file in the MATLAB Editor.

The calling syntax for a C program calling a Fortran function that returns a value in an output argument is platform-dependent. On the Windows platform, the return value needs to be passed in as the first input argument. MATLAB provides a macro, `FORTRAN_COMPLEX_FUNCTIONS_RETURN_VOID`, to handle these differences.

The `dotProductComplex` example computes the dot product X of each element of two complex vectors A and B . The calling syntax is:

```
X = dotProductComplex(A,B)
```

where A and B are complex vectors of the same size and X is a complex scalar.

For example, to build the MEX-file on a Windows 32-bit platform as `dotProductComplex.mexw32`, type:

```
blaslib = fullfile(matlabroot, ...  
    'extern', 'lib', 'win32', 'microsoft', 'libmwblas.lib');  
fortfile = fullfile(matlabroot, 'extern', 'examples', ...  
    'refbook', 'fort.c');  
fortheaderdir = fullfile(matlabroot, 'extern', 'examples', ...  
    'refbook');  
mex('-v', '-largeArrayDims', ['-I' fortheaderdir], ...  
    'dotProductComplex.c', fortfile, blaslib)
```

To test, type;

```
a1 = [1+2i; 2+3i];  
b1 = [-1+2i; -1+3i];  
X = dotProductComplex(a1,b1)
```

MATLAB displays:

```
X =
  -16.0000 + 3.0000i
```

Example — Symmetric Indefinite Factorization Using LAPACK

The example `utdu_slv.c` calls LAPACK functions `zhesvx` and `dsysvx`. To see the example, open the file in the MATLAB Editor. To create the MEX-file, copy the source file to a working folder:

```
copyfile(fullfile(matlabroot, 'extern', 'examples', 'refbook', ...
    'utdu_slv.c'), fullfile('c:', 'work'));
```

To build the file on Windows, type:

```
lapacklib = fullfile(matlabroot, ...
    'extern', 'lib', 'win32', 'microsoft', 'libmwlpack.lib');
fortheaderdir = fullfile(matlabroot, 'extern', 'examples', ...
    'refbook');
mex('-v', '-largeArrayDims', ['-I' fortheaderdir], ...
    'utdu_slv.c', fortfile, lapacklib)
```

To build on a UNIX platform, type:

```
mex -v -largeArrayDims utdu_slv.c -lmwlpack
```

Modifying the Function Name on UNIX Systems

Add an underscore character following the function name when calling LAPACK or BLAS functions on a UNIX system. For example, to call `dgemm`, use:

```
dgemm_(arg1, arg2, ..., argn);
```

Or add these lines to your source code:

```
#if !defined(_WIN32)
#define dgemm dgemm_
#endif
```

Running MEX-Files with .DLL File Extensions on Windows 32-bit Platforms

A MEX-file is a shared library dynamically loaded at runtime. Shared libraries are sometimes called `.dll` files, for dynamically-linked library. MEX-files have a platform-dependent extension, which the `mex` function automatically assigns.

On 32-bit Windows platforms, the extension is `.mexw32`. MATLAB has supported `.dll` as a secondary MEX-file extension since Version 7.1 (R14SP3). In Version 7.7 (R2008b), if you used the `-output` switch to create a MEX-file with a `.dll` extension, MATLAB displayed a warning message that such usage is being phased out.

In MATLAB Version 7.10 (R2010a), you can no longer create a MEX-file with a `.dll` file extension. If you try to, MATLAB creates the MEX-file with the proper extension and displays the following warning:

```
Warning: Output file was specified with file extension, ".dll", which
        is not a proper MEX-file extension. The proper extension for
        this platform, ".mexw32", will be used instead.
```

MATLAB continues to execute a MEX-file with a `.dll` extension, but future versions of MATLAB will not support this extension.

Upgrade MEX-Files to Use 64-Bit API

In this section...

“MATLAB Support for 64-Bit Indexing” on page 3-71

“MEX Uses 32-Bit API by Default” on page 3-71

“What If I Do Not Upgrade?” on page 3-73

“How to Upgrade MEX-Files to Use the 64-Bit API” on page 3-75

MATLAB Support for 64-Bit Indexing

MATLAB Version 7.3 (R2006b) added support for 64-bit indexing. With 64-bit indexing, you can create variables with up to $2^{48}-1$ elements on 64-bit platforms. Before Version 7.3, the C/C++ and Fortran API Reference library functions used `int` in C/C++ and `INTEGER*4` in Fortran to represent array dimensions. These types limit the size of an array to 32-bit integers. Simply building and running MEX-files on a 64-bit platform does not guarantee you access to the additional address space. You must update your MEX source code to take advantage of this functionality.

The following changes to the MX Matrix Library support 64-bit indexing:

- New types, `mwSize` and `mwIndex`, enabling large-sized data.
- Updated MX Matrix Library functions use `mwSize` and `mwIndex` types for inputs and outputs. These functions are called the *64-bit API* or the *large-array-handling API*.
- New `-largeArrayDims` flag for `mex` build command enabling use of the 64-bit API.

To help transition your MEX-files to the 64-bit API, MATLAB maintains an interface, or *compatibility layer*. Use the `-compatibleArrayDims` flag to build MEX-files with this interface.

MEX Uses 32-Bit API by Default

The `mex` command uses the `-compatibleArrayDims` flag (32-bit API) by default. In a future version of MATLAB, the `mex` command will change to use

the large-array-handling API. At that time, the `-largeArrayDims` option will be the default. This topic describes how to upgrade your MEX-files now in preparation for that transition.

Can I Run Existing Binary MEX-Files?

You can run existing binary MEX-files without upgrading the files for use with the 64-bit API. However, unrelated incompatibilities that prevent execution of an existing MEX-file can occur. If your MEX-file does not execute properly, review the MEX Compatibility Considerations topics in the Release Notes for this release. To find MEX topics, check the External Interfaces section of the Compatibility Summary for MATLAB release notes table for each relevant version.

Must I Update Source MEX-Files on 64-Bit Platforms?

If you build MEX-files on 64-bit platforms or write platform-independent applications, you must upgrade your MEX-files when the default changes. To *upgrade*, review your source code, make appropriate changes, and rebuild using the `mex` command.

Previous versions of the External Interfaces Release Notes provide instructions for updating your MEX-files. What action you take now depends on whether your MEX-files currently use the 64-bit API. The following table helps you identify your next actions.

State of Your Source Code	Next Action
I do not plan to update my code.	You have chosen to opt-out and you must build using the <code>-compatibleArrayDims</code> flag.
I want to update my code. Where do I start?	See “How to Upgrade MEX-Files to Use the 64-Bit API” on page 3-75.
I use MEX-files, but do not have access to the source code.	Ask the owner of the source code to follow the steps in “How to Upgrade MEX-Files to Use the 64-Bit API” on page 3-75.

State of Your Source Code	Next Action
I use third-party libraries.	<p>Ask the vendor if the libraries support 64-bit indexing. If not, you cannot use these libraries to create 64-bit MEX-files. Build your MEX-file using the <code>-compatibleArrayDims</code> flag.</p> <p>If the libraries support 64-bit indexing, review your source code, following the steps in “How to Upgrade MEX-Files to Use the 64-Bit API” on page 3-75, and then test.</p>
I updated my code in a previous release.	Review your source code, following the steps in “How to Upgrade MEX-Files to Use the 64-Bit API” on page 3-75, and then test.

Must I Update Source MEX-Files on 32-Bit Platforms?

There are no changes to building 32-bit MEX-files. However, in a future version of MATLAB, the compatibility layer, with the `-compatibleArrayDims` flag, might be unsupported and you then would need to upgrade your MEX-files.

If you build MEX-files exclusively on 32-bit platforms, but want to write platform-independent code, you still can upgrade your code. If possible, build on a 64-bit system to validate your changes.

What If I Do Not Upgrade?

On 32-bit platforms, you do not need to make any changes to build MEX-files.

On 64-bit platforms, you can build MEX-files by using the `-compatibleArrayDims` flag.

On 64-bit platforms, if you do not update your source files and you build without the `-compatibleArrayDims` flag, the results are unpredictable. One or more of the following could occur:

- Increased compiler warnings and/or errors from your native compiler
- Run-time errors
- Wrong answers

How to Upgrade MEX-Files to Use the 64-Bit API

Use the following checklist to review and update MEX-file source code.

- 1** Prepare your code before editing — see “Back Up Files and Create Tests” on page 3-76.
- 2** Iteratively change and test code.

Before building your MEX-files with the 64-bit API, refactor your existing code by checking for the following conditions:

- a** “Update Variables” on page 3-76.
- b** “Replace Unsupported Functions” on page 3-79.
- c** If necessary, “Update Fortran Source Code” on page 3-81.

After each change, build and test your code:

- Build with the 32-bit API. For example, to build `myMexFile.c`, type:

```
mex -compatibleArrayDims myMexFile.c
```

- Test after each refactoring — see “Test, Debug, and Resolve Differences After Each Refactoring Iteration” on page 3-80.

- 3** Compile using the 64-bit API. To build `myMexFile.c`, type:

```
mex -largeArrayDims myMexFile.c
```

- 4** Resolve failures and warnings — see “Resolve `-largeArrayDims` Build Failures and Warnings” on page 3-80.

- 5** Compare Results — see “Execute 64-Bit MEX-File and Compare Results with 32-Bit Version” on page 3-80.

- 6** Check memory — see “Experiment with Large Arrays” on page 3-81.

The following procedures use C/C++ terminology and example code. Fortran MEX-files share the same issues, with additional tasks described in “Update Fortran Source Code” on page 3-81.

Back Up Files and Create Tests

Before adapting your code to handle large arrays, verify the MEX-file works with the traditional 32-bit array dimensions. At a minimum, build a list of expected inputs and outputs, or create a full test suite. Use these tests to compare the results with the upgraded source code. The results should be identical.

Back up all source, binary, and test files.

Update Variables

To handle large arrays, convert variables containing array indices or sizes to use the `mwSize` and `mwIndex` types instead of the 32-bit `int` type. Review your code to see if it contains the following types of variables:

- Variables used directly by the MX Matrix Library functions — see “Update Arguments Used to Call Functions in the 64-Bit API” on page 3-76.
- Intermediate variables — see “Update Variables Used for Array Indices and Sizes” on page 3-77.
- Variables used as both size/index values and as 32-bit integers — see “Analyze Other Variables” on page 3-78.

Update Arguments Used to Call Functions in the 64-Bit API

Identify the 64-bit API functions in your code that use the `mwSize` / `mwIndex` types. For the list of functions, see “Using the 64-Bit API” on page 4-43. Search for the variables that you use to call the functions. Check the function signature, shown under the **Syntax** heading on the function reference page. The signature identifies the variables that take `mwSize` / `mwIndex` values as input or output values. Change your variables to use the correct type.

For example, suppose your code uses the `mxCreateDoubleMatrix` function, as shown in the following statements:

```
int nrows,ncolumns;  
...  
y_out = mxCreateDoubleMatrix(nrows, ncolumns, mxREAL);
```

To see the function signature, type:

```
doc mxCreateDoubleMatrix
```

The signature is: `mxArray *mxCreateDoubleMatrix(mwSize m, mwSize n, mxComplexity ComplexFlag)`

The type for input arguments `m` and `n` is `mwSize`. Change your code as shown in the table.

Replace:	With:
<code>int nrows,ncolumns;</code>	<code>mwSize nrows,ncolumns;</code>

Update Variables Used for Array Indices and Sizes

If your code uses intermediate variables to calculate size and index values, use `mwSize` / `mwIndex` for these variables. For example, the following code declares the inputs to `mxCreateDoubleMatrix` as type `mwSize`:

```
mwSize nrows,ncolumns; /* inputs to mxCreateDoubleMatrix */
int numDataPoints;
nrows = 3;
numDataPoints = nrows * 2;
ncolumns = numDataPoints + 1;
...
y_out = mxCreateDoubleMatrix(nrows, ncolumns, mxREAL);
```

This example uses the intermediate variable, *numDataPoints* (of type `int`), to calculate the value of *ncolumns*. If you copy a 64-bit value from *nrows* into the 32-bit variable, *numDataPoints*, the resulting value truncates. Your MEX-file could crash or produce incorrect results. Use type `mwSize` for *numDataPoints*, as shown in the following table.

Replace:	With:
<code>int numDataPoints;</code>	<code>mwSize numDataPoints;</code>

Analyze Other Variables

You do not need to change every integer variable in your code. For example, field numbers in structures and status codes are of type `int`. However, you need to identify variables used for multiple purposes and, if necessary, replace them with multiple variables.

The following example creates a matrix, *myNumeric*, and a structure, *myStruct*, based on the number of sensors. The code uses one variable, *numSensors*, for both the size of the array and the number of fields in the structure.

```
mxArray *myNumeric, *myStruct;
int numSensors;
mwSize m, n;
char **fieldnames;
...
myNumeric = mxCreateDoubleMatrix(numSensors, n, mxREAL);
myStruct = mxCreateStructMatrix(m, n, numSensors, fieldnames);
```

The function signatures for `mxCreateDoubleMatrix` and `mxCreateStructMatrix` are:

```
mxArray *mxCreateDoubleMatrix(mwSize m, mwSize n,
                               mxComplexity ComplexFlag)
mxArray *mxCreateStructMatrix(mwSize m, mwSize n,
                               int nfields, const char **fieldnames);
```

For the `mxCreateDoubleMatrix` function, your code uses *numSensors* for the variable *m*. The type for *m* is `mwSize`. For the `mxCreateStructMatrix` function, your code uses *numSensors* for the variable *nfields*. The type for *nfields* is `int`. Replace *numSensors* with two new variables to properly handle both functions, as shown in the following table.

Replace:	With:
<pre>int numSensors;</pre>	<pre>/* create 2 variables */ /* of different types */ mwSize numSensorSize; int numSensorFields;</pre>
<pre>myNumeric = mxCreateDoubleMatrix(numSensors, n, mxREAL);</pre>	<pre>/* use mwSize variable */ /* numSensorSize */ myNumeric = mxCreateDoubleMatrix(numSensorSize, n, mxREAL);</pre>
<pre>myStruct = mxCreateStructMatrix(m, n, numSensors, fieldnames);</pre>	<pre>/* use int variable */ /* numSensorFields */ myStruct = mxCreateStructMatrix(m, n, numSensorFields, fieldnames);</pre>

Replace Unsupported Functions

While updating older MEX-files, you could find calls to unsupported functions, such as `mxCreateFull`, `mxGetName`, or `mxIsString`. MATLAB removed support for these functions in Version 7.1 (R14SP3). You cannot use unsupported functions with 64-bit array dimensions. For the list of unsupported functions and the recommended replacements, see “Obsolete Functions No Longer Documented”.

Update your code to use an equivalent function, if available. For example, use `mxCreateDoubleMatrix` instead of `mxCreateFull`.

Test, Debug, and Resolve Differences After Each Refactoring Iteration

To build `myMexFile.c` with the 32-bit API, type:

```
mex -compatibleArrayDims myMexFile.c
```

Use the tests you created at the beginning of this process to compare the results of your updated MEX-file with your original binary file. Both MEX-files should return identical results. If not, debug and resolve any differences. Differences are easier to resolve now than when you build using the 64-bit API.

Resolve `-largeArrayDims` Build Failures and Warnings

After reviewing and updating your code, compile your MEX-file using the large array handling API. To build `myMexFile.c` with the 64-bit API, type:

```
mex -largeArrayDims myMexFile.c
```

Since the `mwSize` / `mwIndex` types are MATLAB types, your compiler sometimes refers to them as `size_t`, `unsigned_int64`, or by other similar names.

Most build problems are related to type mismatches between 32- and 64-bit types. Step 5 in the Technical Support solution 1-5C27B9 identifies common build problems for specific compilers, and possible solutions.

Execute 64-Bit MEX-File and Compare Results with 32-Bit Version

Compare the results of running your MEX-file compiled with the 64-bit API with the results from your original binary. If there are any differences or failures, use a debugger to investigate the cause. For information on the capabilities of your debugger, refer to your compiler documentation.

Step 6 in the Technical Support solution 1-5C27B9 identifies issues you might encounter when running your MEX-files, and possible solutions.

After you resolve any issues and upgrade your MEX-file, it replicates the functionality of your original code while using the large array handling API.

Experiment with Large Arrays

If you have access to a machine with large amounts of memory, you can experiment with large arrays. An array of double-precision floating-point numbers (the default in MATLAB) with 2^{32} elements takes approximately 32 GB of memory.

For an example that demonstrates the use of large arrays, see the `arraySize.c` MEX-file in “Handling Large mxArray” on page 4-43.

Update Fortran Source Code

All of the previous information applies to Fortran, as well as C/C++. Fortran uses similar API signatures, identical `mwSize / mwIndex` types, and similar compilers and debuggers. To make your Fortran source code 64-bit compatible, perform these additional tasks:

- “Use Fortran API Header File” on page 3-81
- “Declare Fortran Pointers” on page 3-81
- “Require Fortran Type Declarations” on page 3-82
- “Use Variables in Function Calls” on page 3-82
- “Manage Reduced Fortran Compiler Warnings” on page 3-83

Use Fortran API Header File. To make your Fortran MEX-file compatible with the 64-bit API, use the `fintrf.h` header file in your Fortran source files. Name your source files with an uppercase `.F` file extension. For more information about these requirements, see “The Components of a Fortran MEX-File” on page 5-2.

Declare Fortran Pointers. Pointers need to be 32- or 64-bit addresses based on machine type. This requirement is not directly tied to array dimensions, but you could encounter problems when moving 32-bit code to 64-bit machines as part of this conversion.

For more information, see “Preprocessor Macros” on page 5-5 and the `mwPointer` reference page.

The C/C++ compiler automatically handles pointer size. In Fortran, MATLAB uses the `mwPointer` type to handle this difference. For example, `mxCreateDoubleMatrix` returns an `mwPointer`:

```
mwPointer mxCreateDoubleMatrix(m, n, ComplexFlag)
mwSize m, n
integer*4 ComplexFlag
```

Require Fortran Type Declarations. Fortran uses implicit type definitions. This means undeclared variables starting with letters I through N are implicitly declared type `INTEGER`. Variable names starting with other letters are implicitly declared type `REAL*4`. Using the implicit `INTEGER` type could work for 32-bit indices, but is not safe for large array dimension MEX-files. Add the `IMPLICIT NONE` statement to your Fortran subroutines to force you to declare all variables. For example:

```
subroutine mexFunction(nlhs, plhs, nrhs, prhs)
implicit none
```

This statement helps identify 32-bit integers in your code that do not have explicit type declarations. Then, you can declare them as `INTEGER*4` or `mwSize / mwIndex`, as appropriate. For more information on `IMPLICIT NONE`, refer to your Fortran compiler documentation.

Use Variables in Function Calls. If you use a number as an argument to a function, your Fortran compiler could assign the argument an incorrect type. On a 64-bit platform, an incorrect types can produce `Out of Memory` errors, segmentation violations, or incorrect results. For example, definitions for the argument types for the `mxCreateDoubleMatrix` function are:

```
mwPointer mxCreateDoubleMatrix(m, n, ComplexFlag)
mwSize m, n
integer*4 ComplexFlag
```

Suppose you have a C/C++ MEX-file with the following statement:

```
myArray = mxCreateDoubleMatrix(2, 3, mxREAL);
```

Most C/C++ compilers interpret the number 2 as a 64-bit value. Some Fortran compilers cannot detect this requirement, and supply a 32-bit value. For example, an equivalent Fortran statement is:

```
myArray = mxCreateDoubleMatrix(2, 3, 0)
```

The compiler interprets the value of the `ComplexFlag` argument 0 correctly as type `INTEGER*4`. However, the compiler could interpret the argument 2 as a 32-bit value, even though the argument `m` is declared type `mwSize`.

A compiler-independent solution to this problem is to declare and use an `mwSize / mwIndex` variable instead of a literal value. For example, the following statements unambiguously call the `mxCreateDoubleMatrix` function in Fortran:

```
mwSize nrows, ncols
INTEGER*4 flag
nrows = 2
ncols = 3
flag = 0
myArray = mxCreateDoubleMatrix(nrows, ncols, flag)
```

Manage Reduced Fortran Compiler Warnings. Some Fortran compilers cannot detect as many type mismatches as similar C/C++ compilers. This inability can complicate the step “Resolve -largeArrayDims Build Failures and Warnings” on page 3-80 by leaving more issues to find with your debugger in the step “Execute 64-Bit MEX-File and Compare Results with 32-Bit Version” on page 3-80.

Platform Compatibility

In this section...

“Verify the MEX-File Is Built For Your Platform” on page 3-84

“Verify Your Architecture on Windows Platforms” on page 3-84

Verify the MEX-File Is Built For Your Platform

If you obtain a binary MEX-file from another source, be sure the file was compiled for the same platform on which you want to run it. The file extension reflects the platform, as shown in the following table. To determine the extension for your platform, use the `mexext` function.

Binary MEX-File Extensions

Platform	Binary MEX-File Extension
Linux (64-bit)	mexa64
Apple Macintosh (64-bit)	mexmaci64
Microsoft Windows (32-bit)	mexw32
Windows (64-bit)	mexw64

Verify Your Architecture on Windows Platforms

Verify the MEX-file is for the same platform, 32- vs. 64-bit.

Invalid MEX-File Error

MATLAB Version Incompatibility

When you try to run a binary MEX-file from a version of MATLAB that is different from the version that created the MEX-file, MATLAB displays an error message of the following form:

```
Invalid MEX-file <mexfilename>:  
The specified module could not be found.
```

DLL Files Not on Path on Windows Systems

MATLAB fails to load binary MEX-files if it cannot find all .dll files referenced by the MEX-file; the .dll files must be on the DOS path or in the same folder as the MEX-file. This is also true for third-party .dll files.

When this happens, MATLAB displays an error message of the following form:

```
Invalid MEX-file <mexfilename>:  
The specified module could not be found.
```

On Windows systems, to find library dependencies, use the third-party product Dependency Walker. Dependency Walker is a free utility that scans any 32-bit or 64-bit Windows module and builds a hierarchical tree diagram of all dependent modules. For each module found, it lists all the functions that are exported by that module, and which of those functions are called by other modules. Download the Dependency Walker utility from the following Web site:

<http://www.dependencywalker.com/>

See the Technical Support solution 1-2RQL4L at <http://www.mathworks.com/support/solutions/data/1-2RQL4L.html> for information on using the Dependency Walker.

Before You Run a MEX-File You Receive from Someone Else

A MEX-file is a function, created in MATLAB, that calls C, C++, or Fortran subroutines. To call a MEX-file, use the name of the file, without the file extension. The file must be on your MATLAB path.

If you cannot run a MEX-file that you did not create, consider the following:

- “Platform Compatibility” on page 3-84
- “Version Compatibility” on page 3-87
- Install the compiler used to create the MEX-file.
- If the MEX-file uses specialized runtime libraries, those libraries must be installed on your system. For troubleshooting information, see “DLL Files Not on Path on Windows Systems” on page 3-85.

A MEX-file is a *dynamically-linked* subroutine that the MATLAB interpreter loads and executes when you call the function. Dynamic linking means that when you call the function, the program looks for dependent libraries. MEX-files use MATLAB runtime libraries and language-specific libraries. A MEX-file might also use specialized runtime libraries. The code for these libraries is not included in the MEX-file; the libraries must be present on your computer when you run the MEX-file.

If you write a MEX-file, build it, and then execute it in the same MATLAB session, all of the dependent libraries are available, as expected. However, if you receive a MEX-file from another MATLAB user, you might not have all of the dependent libraries.

Version Compatibility

For best results, your version of MATLAB must be the same version that was used to create the MEX-file.

MEX-files use MATLAB runtime libraries. MEX-files are usually backwards compatible, which means you can run a MEX-file that was created on an earlier version of MATLAB on later versions of MATLAB. If the MEX-file generates errors, recompile the MEX-file from the source code.

Sometimes a MEX-file created on a newer version of MATLAB runs on an older version of MATLAB (forward compatibility), but this is not supported.

Troubleshooting MEX-Files

Technical Support

<http://www.mathworks.com/support/>

Configuration Issues

In this section...

“Search Path Problem on Microsoft Windows Systems” on page 3-89

“MATLAB Path Names Containing Spaces on Windows Systems” on page 3-89

“Internal Error When Using `mex -setup ()`” on page 3-89

Search Path Problem on Microsoft Windows Systems

On Windows systems, if you move the MATLAB executable without reinstalling the MATLAB software, you might need to modify `mex.bat` to point to the new MATLAB location.

MATLAB Path Names Containing Spaces on Windows Systems

If you have problems building MEX-files on Windows systems and there is a space in any of the folder names within the MATLAB path, either reinstall MATLAB into a path name that contains no spaces or rename the folder that contains the space. For example, if you install MATLAB under the Program Files folder, you might have difficulty building MEX-files with certain C/C++ compilers.

Internal Error When Using `mex -setup ()`

Some antivirus software packages might conflict with the `mex -setup` process or other `mex` commands. If you get an error message of the following form in response to a `mex` command:

```
mex.bat: internal error in sub get_compiler_info(): don't
recognize <string>
```

then you need to disable your antivirus software temporarily and reenter the command. After you have successfully run the `mex` script, you can reenable your antivirus software.

Alternatively, you can open a separate MS-DOS window and enter the `mex` command from that window.

Understanding MEX-File Problems

Use the following figure to help isolate common problems that occur when creating binary MEX-files.

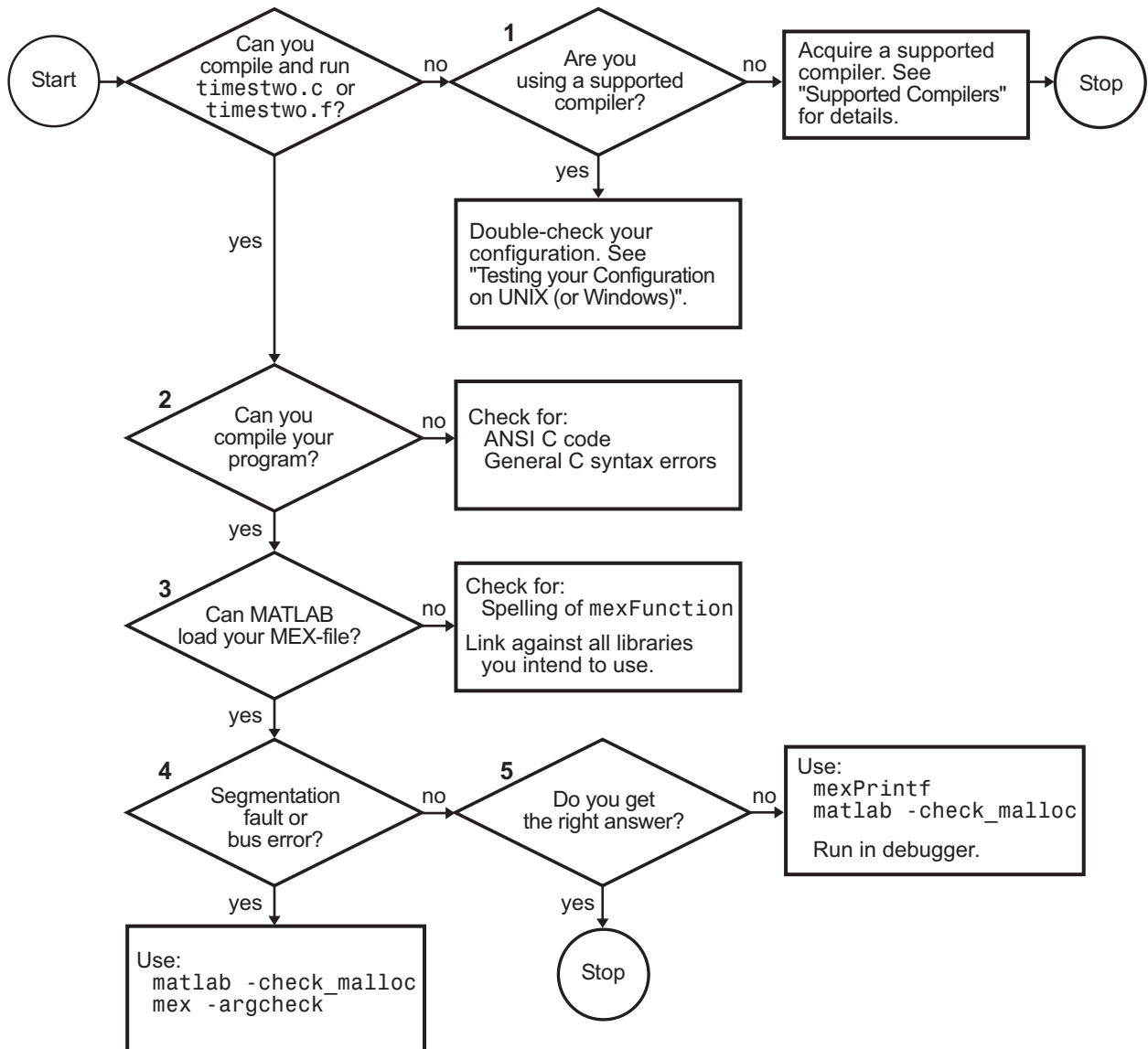

Troubleshooting MEX-File Creation Problems

In this section...

“Problem 1 — Compiling a Source MEX-File Fails” on page 3-92

“Problem 2 — Compiling Your Own Program Fails” on page 3-92

“Problem 3 — Binary MEX-File Load Errors” on page 3-93

“Problem 4 — Segmentation Fault” on page 3-94

“Problem 5 — Program Generates Incorrect Results” on page 3-94

Problems 1 through 5 refer to the corresponding numbered sections of the previous flowchart. For additional suggestions on resolving MEX-file build problems, see the MathWorks Technical Support Web site at:

<http://www.mathworks.com/support>

Problem 1 — Compiling a Source MEX-File Fails

Syntax Errors Compiling C/C++ MEX-Files on UNIX

The most common configuration problem in creating C/C++ source MEX-files on UNIX systems involves using a non-ANSI C compiler, or failing to pass to the compiler a flag that tells it to compile ANSI C code.

A reliable way of knowing if you have this type of configuration problem is if the header files supplied by MATLAB generate a string of syntax errors when you try to compile your code. See “Build MEX-Files” on page 3-27 for information on selecting the appropriate options file or, if necessary, obtain an ANSI C compiler.

Problem 2 — Compiling Your Own Program Fails

Mixing ANSI and non-ANSI C code can generate a string of syntax errors. MATLAB provides header and source files that are ANSI C compliant. Therefore, your C code must also be ANSI compliant.

Other common problems that can occur in any C/C++ program are neglecting to include all necessary header files, or neglecting to link against all required libraries.

Make sure you are using a MATLAB-supported compiler. See “What You Need to Build MEX-Files” on page 3-27 for this information. Additional information can be found in “Compiler- and Platform-Specific Issues” on page 3-96.

Symbol mexFunction Unresolved or Not Defined

Attempting to compile a MEX-function that does not include a gateway function generates errors about the mexFunction symbol. For example, using a C/C++ compiler, MATLAB displays information like:

```
LINK : error LNK2001: unresolved external symbol mexFunction
```

Using a Fortran compiler, MATLAB displays information like:

```
unresolved external symbol _MEXFUNCTION
```

If you want to call functions from a C/C++ or Fortran library from MATLAB, you must write a gateway function, as described in “Create a Gateway Routine” on page 3-6.

Problem 3 – Binary MEX-File Load Errors

If you receive an error of the form:

```
Unable to load mex file:  
Invalid MEX-file
```

MATLAB does not recognize your MEX-file.

MATLAB loads MEX-files by looking for the gateway routine, mexFunction. If you misspell the function name, MATLAB cannot load your MEX-file and generates an error message. On Windows systems, check that you are exporting mexFunction correctly.

On some platforms, if you fail to link against required libraries, you might get an error when MATLAB loads your MEX-file rather than when you compile your MEX-file. In such cases, a system error message referring to *unresolved symbols* or *unresolved references* appears. Be sure to link against the library that defines the function in question.

On Windows systems, MATLAB fails to load MEX-files if it cannot find all .dll files referenced by the MEX-file; the .dll files must be on the path or in the same folder as the MEX-file. This is also true for third-party .dll files. See “DLL Files Not on Path on Windows Systems” on page 3-85 for information to diagnose this problem.

Problem 4 – Segmentation Fault

If a binary MEX-file causes a segmentation violation or assertion, it means the MEX-file attempted to access protected, read-only, or unallocated memory.

These types of programming errors are sometimes difficult to track down. Segmentation violations do not always occur at the same point as the logical errors that cause them. If a program writes data to an unintended section of memory, an error might not occur until the program reads and interprets the corrupted data. Consequently, a segmentation violation can occur after the MEX-file finishes executing.

One cause of memory corruption is to pass a null pointer to a function. To check for this condition, add code in your MEX-file to check for invalid arguments to MEX Library and MX Matrix Library API functions.

To troubleshoot problems of this nature, run MATLAB within a debugging environment. For more information, see “Debug C/C++ Language MEX-Files” on page 4-32 or “Debug Fortran Source MEX-Files” on page 5-24.

Problem 5 – Program Generates Incorrect Results

If your program generates the wrong answer(s), there are several causes. First, there could be an error in the computational logic. Second, the program could be reading from an uninitialized section of memory. For example, reading the 11th element of a 10-element vector yields unpredictable results.

Another cause of generating a wrong answer could be overwriting valid data due to memory mishandling. For example, writing to the 15th element of a 10-element vector might overwrite data in the adjacent variable in memory. This case can be handled in a similar manner as segmentation violations, as described in Problem 4.

In all of these cases, you can use `mexPrintf` to examine data values at intermediate stages or run MATLAB within a debugger to exploit all the tools the debugger provides.

Compiler- and Platform-Specific Issues

In this section...
“Linux gcc Compiler Version Error” on page 3-96
“Linux gcc -fPIC Errors” on page 3-96
“Watcom IDE Unresolved References” on page 3-96

Linux gcc Compiler Version Error

For information concerning a gcc compiler version error on Linux systems, see the Technical Support solution 1-2H64MF.

Linux gcc -fPIC Errors

If you link a static library with a MEX-file, which is a shared library, you might get an error message containing the text `recompile with -fPIC`. Try compiling the static library with the `-fPIC` flag in order to create position independent code. For information about using the gcc compiler, see www.gnu.org. For an up-to-date list of supported compilers, see the Supported and Compatible Compilers Web page.

Watcom IDE Unresolved References

If you use the Watcom IDE to create MEX-files and get unresolved references to API functions when linking against our libraries, check the argument-passing convention. The Watcom IDE uses a default switch that passes parameters in registers. MATLAB requires that you pass parameters on the stack.

Memory Management Issues

In this section...

“Overview” on page 3-97

“Improperly Destroying an mxArray” on page 3-98

“Incorrectly Constructing a Cell or Structure mxArray” on page 3-98

“Creating a Temporary mxArray with Improper Data” on page 3-99

“Creating Potential Memory Leaks” on page 3-100

“Improperly Destroying a Structure” on page 3-101

“Destroying Memory in a C++ Class Destructor” on page 3-102

Overview

When a binary MEX-file returns control to MATLAB, it returns the results of its computations in the output arguments—the mxArray's contained in the left-hand side arguments `plhs[]`. MATLAB destroys any mxArray created by the MEX-file that is not in this argument list. In addition, MATLAB frees any memory that was allocated in the MEX-file using the `mxMalloc`, `mxRealloc`, or `mxRealloc` functions.

In general, MathWorks recommends that MEX-file functions destroy their own temporary arrays and free their own dynamically allocated memory. It is more efficient to perform this cleanup in the source MEX-file than to rely on the automatic mechanism. This approach is consistent with other MATLAB API applications (MAT-file applications, engine applications, and MATLAB Compiler generated applications, which do not have any automatic cleanup mechanism.)

However, you should not destroy an mxArray in a source MEX-file when it is:

- passed to the MEX-file in the right-hand side list `prhs[]`
- returned in the left-hand side list `plhs[]`
- returned by `mexGetVariablePtr`
- used to create a structure

This section describes situations specific to memory management. We recommend you review code in your source MEX-files to avoid using these functions in the following situations. For additional information, see “Memory Management” on page 4-47 in *Creating C/C++ Language MEX-Files*. For guidance on memory issues, see “Strategies for Efficient Use of Memory”.

Potential memory management problems include:

Improperly Destroying an mxArray

Do not use `mxFree` to destroy an `mxArray`.

Example

In the following example, `mxFree` does not destroy the array object. This operation frees the structure header associated with the array, but MATLAB stills operates as if the array object needs to be destroyed. Thus MATLAB tries to destroy the array object, and in the process, attempts to free its structure header again:

```
mxArray *temp = mxCreateDoubleMatrix(1,1,mxREAL);  
    ...  
mxFree(temp); /* INCORRECT */
```

Solution

Call `mxDestroyArray` instead:

```
mxDestroyArray(temp); /* CORRECT */
```

Incorrectly Constructing a Cell or Structure mxArray

Do not call `mxSetCell` or `mxSetField` variants with `prhs[]` as the member array.

Example

In the following example, when the MEX-file returns, MATLAB destroys the entire cell array. Since this includes the members of the cell, this implicitly destroys the MEX-file’s input arguments. This can cause several strange results, generally having to do with the corruption of the caller’s workspace,

if the right-hand side argument used is a temporary array (for example, a literal or the result of an expression):

```
myfunction('hello')
/* myfunction is the name of your MEX-file and your code
/* contains the following: */

    mxArray *temp = mxCreateCellMatrix(1,1);
    ...
    mxSetCell(temp, 0, prhs[0]); /* INCORRECT */
```

Solution

Make a copy of the right-hand side argument with `mxDuplicateArray` and use that copy as the argument to `mxSetCell` (or `mxSetField` variants). For example:

```
mxSetCell(temp, 0, mxDuplicateArray(prhs[0])); /* CORRECT */
```

Creating a Temporary mxArray with Improper Data

Do not call `mxDestroyArray` on an `mxArray` whose data was not allocated by an API routine.

Example

If you call `mxSetPr`, `mxSetPi`, `mxSetData`, or `mxSetImagData`, specifying memory that was not allocated by `mxMalloc`, `mxRealloc`, or `mxRealloc` as the intended data block (second argument), then when the MEX-file returns, MATLAB attempts to free the pointers to real data and imaginary data (if any). Thus MATLAB attempts to free memory, in this example, from the program stack:

```
mxArray *temp = mxCreateDoubleMatrix(0,0,mxREAL);
double data[5] = {1,2,3,4,5};
...
mxSetM(temp,1); mxSetN(temp,5); mxSetPr(temp, data);
/* INCORRECT */
```

Solution

Rather than use `mxSetPr` to set the data pointer, instead, create the `mxArray` with the right size and use `memcpy` to copy the stack data into the buffer returned by `mxGetPr`:

```
mxArray *temp = mxCreateDoubleMatrix(1,5,mxREAL);
double data[5] = {1,2,3,4,5};
...
memcpy(mxGetPr(temp), data, 5*sizeof(double)); /* CORRECT */
```

Creating Potential Memory Leaks

Prior to Version 5.2, if you created an `mxArray` using one of the API creation routines and then you overwrote the pointer to the data using `mxSetPr`, MATLAB still freed the original memory. This is no longer the case.

For example:

```
pr = mxCalloc(5*5, sizeof(double));
... <load data into pr>
plhs[0] = mxCreateDoubleMatrix(5,5,mxREAL);
mxSetPr(plhs[0], pr); /* INCORRECT */
```

will now leak $5*5*8$ bytes of memory, where 8 bytes is the size of a double.

You can avoid that memory leak by changing the code to:

```
plhs[0] = mxCreateDoubleMatrix(5,5,mxREAL);
pr = mxGetPr(plhs[0]);
... <load data into pr>
```

or alternatively:

```
pr = mxCalloc(5*5, sizeof(double));
... <load data into pr>
plhs[0] = mxCreateDoubleMatrix(5,5,mxREAL);
mxFree(mxGetPr(plhs[0]));
mxSetPr(plhs[0], pr);
```

Note that the first solution is more efficient.

Similar memory leaks can also occur when using `mxSetPi`, `mxSetData`, `mxSetImagData`, `mxSetIr`, or `mxSetJc`. You can avoid memory leaks by changing the code as described in this section.

Improperly Destroying a Structure

For a structure, you must call `mxDestroyArray` only on the structure, not on the field data arrays. A field in the structure points to the data in the array used by `mxSetField` or `mxSetFieldByNumber`. When `mxDestroyArray` destroys the structure, it attempts to traverse down through itself and free all other data, including the memory in the data arrays. If you call `mxDestroyArray` on each data array, the same memory is freed twice and this can corrupt memory.

Example

The following example creates three arrays: one structure array `aStruct` and two data arrays, `myDataOne` and `myDataTwo`. Field name `one` contains a pointer to the data in `myDataOne`, and field name `two` contains a pointer to the data in `myDataTwo`.

```
mxArray *myDataOne;
mxArray *myDataTwo;
mxArray *aStruct;
const char *fields[] = { "one", "two" };

myDataOne = mxCreateDoubleScalar(1.0);
myDataTwo = mxCreateDoubleScalar(2.0);

aStruct = mxCreateStructMatrix(1,1,2,fields);
mxSetField( aStruct, 0, "one", myDataOne );
mxSetField( aStruct, 1, "two", myDataTwo );
mxDestroyArray(myDataOne);
mxDestroyArray(myDataTwo);
mxDestroyArray(aStruct); /* tries to free myDataOne and myDataTwo */
```

Solution

The command `mxDestroyArray(aStruct)` destroys the data in all three arrays:

```
...  
aStruct = mxCreateStructMatrix(1,1,2,fields);  
mxSetField( aStruct, 0, "one", myDataOne );  
mxSetField( aStruct, 1, "two", myDataTwo );  
mxDestroyArray(aStruct);
```

Destroying Memory in a C++ Class Destructor

Do not use the `mxFree` or `mxDestroyArray` functions in a C++ destructor of a class used in a MEX-function. If the MEX-function throws an error, MATLAB cleans up MEX-file variables, as described in “Automatic Cleanup of Temporary Arrays” on page 4-47.

If an error occurs that causes the object to go out of scope, MATLAB calls the C++ destructor. Freeing memory directly in the destructor means both MATLAB and the destructor free the same memory, which can corrupt memory.

Compiler Errors in Fortran MEX-Files

When you compile a Fortran MEX-file using a free source form format, MATLAB displays an error message of the following form:

```
Illegal character in statement label field
```

mex supports the fixed source form. The difference between free and fixed source forms is explained in the Fortran Language Reference Manual Source Forms topic. The URL for this topic is:

```
http://h21007.www2.hp.com/portal/download/files/unprot/Fortran/docs/lrm/lrm0015.htm#source\_formatmenu?&Record=383697&STASH=7
```

The URL for the Fortran Language Reference Manual is:

```
http://h21007.www2.hp.com/portal/download/files/unprot/Fortran/docs/lrm/dflrm.htm
```

C/C++ MEX-Files

- “C/C++ Source MEX-Files” on page 4-2
- “Set Up C/C++ Examples” on page 4-11
- “Pass Scalar Values” on page 4-12
- “Pass Strings” on page 4-14
- “Pass Multiple Inputs or Outputs” on page 4-16
- “Pass Structures and Cell Arrays” on page 4-18
- “Create 2-D Cell Array” on page 4-20
- “Fill mxArray” on page 4-21
- “Prompt User for Input” on page 4-22
- “Handle Complex Data” on page 4-23
- “Handle 8-, 16-, and 32-Bit Data” on page 4-24
- “Manipulate Multidimensional Numerical Arrays” on page 4-25
- “Handle Sparse Arrays” on page 4-27
- “Call MATLAB Functions from C/C++ MEX-Files” on page 4-28
- “Use C++ Features in MEX-Files” on page 4-29
- “Handle Files with C++” on page 4-30
- “Debug C/C++ Language MEX-Files” on page 4-32
- “Handling Large mxArray” on page 4-43
- “Memory Management” on page 4-47
- “Handling Large File I/O” on page 4-50

C/C++ Source MEX-Files

In this section...

“The Components of a C/C++ MEX-File” on page 4-2

“Gateway Routine” on page 4-2

“Computational Routine” on page 4-5

“Preprocessor Macros” on page 4-5

“Data Flow in MEX-Files” on page 4-5

“Creating C++ MEX-Files” on page 4-9

The Components of a C/C++ MEX-File

You create binary MEX-files using the `mex` build script. `mex` compiles and links source files into a shared library called a binary MEX-file, which you can run at the MATLAB command line. Once compiled, you treat binary MEX-files like MATLAB functions.

This section explains the components of a source MEX-file, statements you use in a program source file. Unless otherwise specified, the term “MEX-file” refers to a source file.

The MEX-file consists of:

- A “Gateway Routine” on page 4-2 that interfaces C/C++ and MATLAB data.
- A “Computational Routine” on page 4-5 written in C/C++ that performs the computations you want implemented in the binary MEX-file.
- “Preprocessor Macros” on page 4-5 for building platform-independent code.

Gateway Routine

The *gateway routine* is the entry point to the MEX-file shared library. It is through this routine that MATLAB accesses the rest of the routines in your MEX-files. Use the following guidelines to create a gateway routine:

- “Naming the Gateway Routine” on page 4-3

- “Required Parameters” on page 4-3
- “Creating and Using Source Files” on page 4-4
- “Using MATLAB Libraries” on page 4-4
- “Required Header Files” on page 4-4
- “Naming the MEX-File” on page 4-4

The following is a sample C/C++ MEX-file gateway routine:

```
void mexFunction(
    int nlhs, mxArray *plhs[],
    int nrhs, const mxArray *prhs[])
{
    /* more C/C++ code ... */
}
```

Naming the Gateway Routine

The name of the gateway routine must be `mexFunction`.

Required Parameters

A gateway routine must contain the parameters *prhs*, *nrhs*, *plhs*, and *nlhs* described in the following table.

Parameter	Description
<i>prhs</i>	An array of right-hand input arguments.
<i>plhs</i>	An array of left-hand output arguments.
<i>nrhs</i>	The number of right-hand arguments, or the size of the <i>prhs</i> array.
<i>nlhs</i>	The number of left-hand arguments, or the size of the <i>plhs</i> array.

Declare *prhs* and *plhs* as type `mxArray *`, which means they point to MATLAB arrays. They are vectors that contain pointers to the arguments of the MEX-file.

You can think of the name *prhs* as representing the “parameters, right-hand side,” that is, the input parameters. Likewise, *plhs* represents the “parameters, left-hand side,” or output parameters.

Creating and Using Source Files

It is good practice to write the gateway routine to call a “Computational Routine” on page 4-5; however, this is not required. The computational code can be part of the gateway routine. If you use both gateway and computational routines, you can combine them into one source file or into separate files. If you use separate files, the gateway routine must be the first source file listed in the `mex` command.

The name of the file containing your gateway routine is important, as explained in “Naming the MEX-File” on page 4-4.

Using MATLAB Libraries

The MX Matrix Library and the MEX Library describe functions you can use in your gateway and computational routines that interact with MATLAB programs and the data in the MATLAB workspace. The MX Matrix Library functions provide access methods for manipulating MATLAB arrays. The MEX Library functions perform operations in the MATLAB environment.

Required Header Files

To use the functions in the C/C++ and Fortran API Reference library you must include the `mex` header, which declares the entry point and interface routines. Put this statement in your source file:

```
#include "mex.h"
```

Naming the MEX-File

The binary MEX-file name, and hence the name of the function you use in MATLAB, is the name of the source file containing your gateway routine.

The file extension of the binary MEX-file is platform-dependent. You find the file extension using the `mexext` function, which returns the value for the current machine.

Computational Routine

The *computational routine* contains the code for performing the computations you want implemented in the binary MEX-file. Computations can be numerical computations as well as inputting and outputting data. The gateway calls the computational routine as a subroutine.

The programming requirements described in “Creating and Using Source Files” on page 4-4, “Using MATLAB Libraries” on page 4-4, and “Required Header Files” on page 4-4 might also apply to your computational routine.

Preprocessor Macros

The MX Matrix and MEX libraries use the MATLAB *preprocessor macros* `mwSize` and `mwIndex` for cross-platform flexibility. `mwSize` represents size values, such as array dimensions and number of elements. `mwIndex` represents index values, such as indices into arrays.

Data Flow in MEX-Files

The following examples illustrate data flow in MEX-files:

- “Showing Data Input and Output” on page 4-5
- “Gateway Routine Data Flow Diagram” on page 4-6
- “MATLAB Example `yprime.c`” on page 4-7

Showing Data Input and Output

Suppose your MEX-file `myFunction` has two input arguments and one output argument. The MATLAB syntax is `[X] = myFunction(Y, Z)`. To call `myFunction` from MATLAB, type:

```
X = myFunction(Y, Z);
```

The MATLAB interpreter calls `mexFunction`, the gateway routine to `myFunction`, with the following arguments:

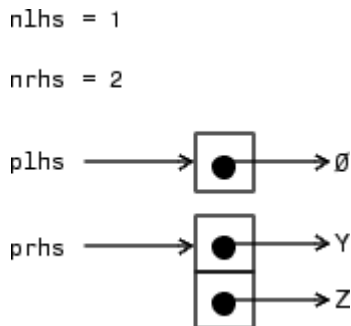

Your input is `prhs`, a two-element array (`nrhs = 2`). The first element is a pointer to an mxArray named `Y` and the second element is a pointer to an mxArray named `Z`.

Your output is `plhs`, a one-element array (`nlhs = 1`) where the single element is a null pointer. The parameter `plhs` points at nothing because the output `X` is not created until the subroutine executes.

The gateway routine creates the output array and sets a pointer to it in `plhs[0]`. If the routine does not assign a value to `plhs[0]` but you assign an output value to the function when you call it, MATLAB generates an error.

Note It is possible to return an output value even if `nlhs = 0`. This corresponds to returning the result in the *ans* variable.

Gateway Routine Data Flow Diagram

The following MEX Cycle diagram shows how inputs enter a MEX-file, what functions the gateway routine performs, and how outputs return to MATLAB.

In this example, the syntax of the MEX-file `func` is `[C, D] = func(A,B)`. In the figure, a call to `func` tells MATLAB to pass variables `A` and `B` to your MEX-file. `C` and `D` are left unassigned.

The gateway routine `func.c` uses the `mxCreate*` functions to create the MATLAB arrays for your output arguments. It sets `plhs[0]` and `plhs[1]` to the pointers to the newly created MATLAB arrays. It uses the `mxGet*`

functions to extract your data from your input arguments `prhs[0]` and `prhs[1]`. Finally, it calls your computational routine, passing the input and output data pointers as function parameters.

MATLAB assigns `plhs[0]` to `C` and `plhs[1]` to `D`.

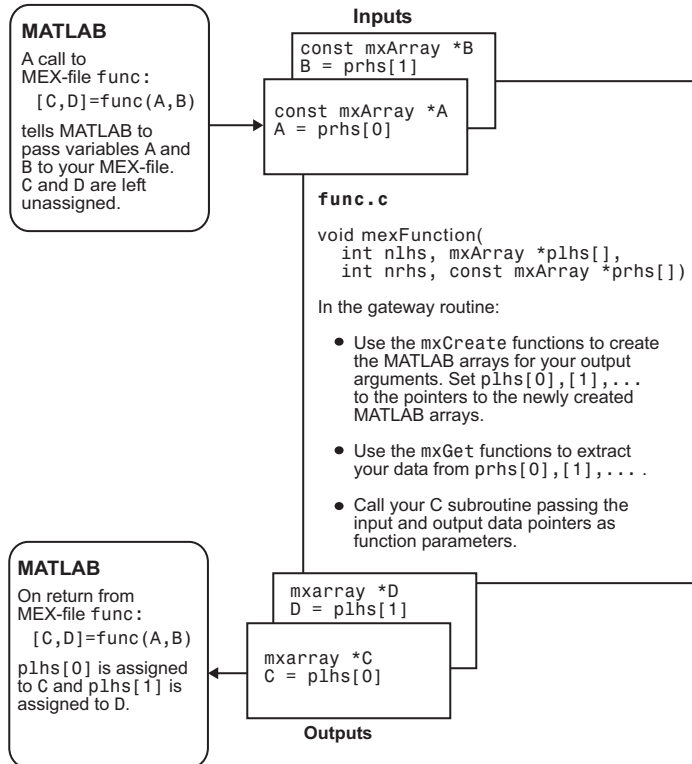

C/C++ MEX Cycle

MATLAB Example `yprime.c`

Look at the example, `yprime.c`, found in your `matlabroot/extern/examples/mex/` folder. (“Build MEX-Files” on page 3-27 explains how to create the binary MEX-file.) Its calling syntax is `[YP] = YPRIME(T,Y)`, where `T` is an integer and `Y` is a vector with four elements. For `T=1` and `Y=1:4`, when you type:

```
yprime(T,Y)
```

MATLAB displays:

```
ans =  
    2.0000    8.9685    4.0000   -1.0947
```

The gateway routine validates the input arguments. This step includes checking the number, type, and size of the input arrays as well as examining the number of output arrays. If the inputs are not valid, call `mexErrMsgIdAndTxt`. For example:

```
/* Check for proper number of arguments */  
if (nrhs != 2) {  
    mexErrMsgTxt("Two input arguments required.");  
} else if (nlhs > 1) {  
    mexErrMsgTxt("Too many output arguments.");  
}  
  
/* Check the dimensions of Y. Y can be 4 X 1 or 1 X 4. */  
m = mxGetM(Y_IN);  
n = mxGetN(Y_IN);  
if (!mxIsDouble(Y_IN) || mxIsComplex(Y_IN) ||  
    (MAX(m,n) != 4) || (MIN(m,n) != 1)) {  
    mexErrMsgTxt("YPRIME requires that Y be a 4 x 1 vector.");  
}
```

To create MATLAB arrays, call one of the `mxCreate*` functions, like `mxCreateDoubleMatrix`, `mxCreateSparse`, or `mxCreateString`. If it needs them, the gateway routine can call `mxMalloc` to allocate temporary work arrays for the computational routine. In this example:

```
/* Create a matrix for the return argument */  
plhs[0] = mxCreateDoubleMatrix(m, n, mxREAL);
```

In the gateway routine, you access the data in `mxArray` and manipulate it in your computational subroutine. For example, the expression `mxGetPr(prhs[0])` returns a pointer of type `double *` to the real data in the `mxArray` pointed to by `prhs[0]`. You can then use this pointer like any other pointer of type `double *` in C/C++. For example:

```
/* Assign pointers to the various parameters */  
yp = mxGetPr(plhs[0]);
```

In this example, a computational routine, `yprime`, performs the calculations:

```
/* Do the actual computations in a subroutine */  
yprime(yp,t,y);
```

After calling your computational routine from the gateway, you can set a pointer of type `mxArray` to the data it returns. MATLAB recognizes the output from your computational routine as the output from the binary MEX-file.

When a binary MEX-file completes its task, it returns control to MATLAB. MATLAB automatically destroys any arrays created by the MEX-file not returned through the left-hand side arguments.

MathWorks recommends that MEX-file functions destroy their own temporary arrays and free their own dynamically allocated memory. It is more efficient to perform this cleanup in the source MEX-file than to rely on the automatic mechanism.

Creating C++ MEX-Files

MEX-files support all C++ language standards.

This section discusses specific C++ language issues to consider when creating and using MEX-files.

Creating Your C++ Source File

The C++ source code for the examples provided by MATLAB use the `.cpp` file extension. The extension `.cpp` is unambiguous and generally recognized by C++ compilers. Other possible extensions include `.C`, `.cc`, and `.cxx`.

Compiling and Linking

You can run a C++ MEX-file only on systems with the same version of MATLAB that the file was compiled on.

Use `mex -setup` to select a C++ compiler, then type:

```
mex filename.cpp
```

You can use command-line options, as shown in the “MEX Script Switches” on page 3-43 table.

Your link command must have all the necessary DLL files that the MEX-function is dependent upon. To help you check for dependent files, see the Troubleshooting topic “DLL Files Not on Path on Windows Systems” on page 3-85.

Examples

The examples “Use C++ Features in MEX-Files” on page 4-29 and “Handle Files with C++” on page 4-30 illustrate the use of C++ by walking through source code examples available in your MATLAB folder.

Memory Considerations For Class Destructors

Do not use the `mxFree` or `mxDestroyArray` functions in a C++ destructor of a class used in a MEX-function. If the MEX-function throws an error, MATLAB cleans up MEX-file variables, as described in “Automatic Cleanup of Temporary Arrays” on page 4-47.

If an error occurs that causes the object to go out of scope, MATLAB calls the C++ destructor. Freeing memory directly in the destructor means both MATLAB and the destructor free the same memory, which can corrupt memory.

Use `mexPrintf` to Print to the MATLAB Command Window

Using `cout` or the C-language `printf` function does not work as expected in C++ MEX-files. Use the `mexPrintf` function instead.

Set Up C/C++ Examples

The MX Matrix Library provides a full set of routines that handle the types supported by MATLAB. For each data type there is a specific set of functions that you can use for data manipulation. The first example discusses the simple case of doubling a scalar. After that, the examples discuss how to pass in, manipulate, and pass back various data types, and how to handle multiple inputs and outputs. Finally, the sections discuss passing and manipulating various MATLAB types.

Source code for the examples in this section are in the *matlabroot/extern/examples/refbook* folder. To build an example, first copy the file to a writable folder, such as *c:\work*, on your path:

```
copyfile(fullfile(matlabroot, 'extern', 'examples', 'refbook', ...  
    'filename.c'), fullfile('c:', 'work'));
```

where *filename* is the name of the example.

Make sure that you have a C/C++ compiler selected using the `mex -setup` command. Then at the MATLAB command prompt, type:

```
mex filename.c
```

The following topics look at source code for the examples. Unless otherwise specified, the term "MEX-file" refers to a source file.

For a list of MEX example files available with MATLAB, see "Table of MEX-File Source Code Files" on page 3-38.

Pass Scalar Values

Look at a simple example of C code and its MEX-file equivalent. This computational function takes a scalar and doubles it:

```
#include <math.h>
void timestwo(double y[], double x[])
{
    y[0] = 2.0*x[0];
    return;
}
```

To see the same function written in the MEX-file format (`timestwo.c`), open the file in MATLAB Editor.

In C/C++, the compiler checks function arguments. In MATLAB, you can pass any number or type of arguments to a function, which is responsible for argument checking. This is also true for MEX-files. Your program must safely handle any number of input or output arguments of any supported type.

To compile and link this example, at the MATLAB prompt, type:

```
mex timestwo.c
```

MATLAB creates the binary MEX-file called `timestwo` with an extension corresponding to the platform on which you are running. You can now call `timestwo` like a MATLAB function:

```
x = 2;
y = timestwo(x)
y =
     4
```

You can create and compile MEX-files in MATLAB or at your operating system prompt. MATLAB uses the `mex.m` file. The Microsoft Windows operating system uses the `mex.bat` file, and UNIX uses the `mex.sh` file. Typing:

```
mex filename
```

at either prompt produces a compiled version of your MEX-file.

The previous example views scalars as 1-by-1 matrices. Alternatively, you can use a special API function called `mxGetScalar` that returns the values of scalars instead of pointers to copies of scalar variables (`timestwoalt.c`). To see the alternative code (error checking has been omitted for brevity), open the file in MATLAB Editor.

This example passes the input scalar `x` by value into the `timestwo_alt` subroutine, but passes the output scalar `y` by reference.

Pass Strings

You can pass any MATLAB type to and from MEX-files. The example `revord.c` accepts a string and returns the characters in reverse order. To see the example, open the file in MATLAB Editor.

In this example, the API function `mxMalloc` replaces `calloc`, the standard C/C++ function for dynamic memory allocation. `mxMalloc` allocates dynamic memory using the MATLAB memory manager and initializes it to zero. Use `mxMalloc` in any situation where C/C++ would require the use of `calloc`. The same is true for `mxMalloc` and `mxRealloc`; use `mxMalloc` in any situation where C/C++ would require the use of `malloc` and use `mxRealloc` where C/C++ would require `realloc`.

Note MATLAB automatically frees up memory allocated with the MX Matrix Library allocation routines (`mxMalloc`, `mxMalloc`, `mxRealloc`) upon exiting your MEX-file. If you do not want to free this memory, use the API function `mexMakeMemoryPersistent`.

The gateway routine `mexFunction` allocates memory for the input and output strings. Since these are C-style strings, they need to be one greater than the number of elements in the MATLAB string. Next, the MATLAB string is copied to the input string. Both the input and output strings are passed to the computational subroutine (`revord`), which loads the output in reverse order. The output buffer is a valid null-terminated C string because `mxMalloc` initializes the memory to 0. The API function `mxCreateString` then creates a MATLAB string from the C string, `output_buf`. Finally, `plhs[0]`, the left-hand side return argument to MATLAB, is set to the MATLAB array you just created.

By isolating variables of type `mxArray` from the computational subroutine, you can avoid having to make significant changes to your original C/C++ code.

To build this example, at the command prompt type:

```
mex revord.c
```

Type:

```
x = 'hello world';  
y = revord(x)
```

MATLAB displays:

```
y =  
dlrow olleh
```

Pass Multiple Inputs or Outputs

The *plhs* [] and *prhs* [] parameters are vectors that contain pointers to each left-hand side (output) variable and each right-hand side (input) variable, respectively. Accordingly, *plhs*[0] contains a pointer to the first left-hand side argument, *plhs*[1] contains a pointer to the second left-hand side argument, and so on. Likewise, *prhs*[0] contains a pointer to the first right-hand side argument, *prhs*[1] points to the second, and so on.

This example, `xtimesy`, multiplies an input scalar by an input scalar or matrix and outputs a matrix.

To build this example, at the command prompt type:

```
mex xtimesy.c
```

Use `xtimesy` with two scalars:

```
x = 7;  
y = 7;  
z = xtimesy(x,y)
```

MATLAB displays:

```
z =  
    49
```

Use `xtimesy` with a scalar and a matrix:

```
x = 9;  
y = ones(3);  
z = xtimesy(x,y)
```

MATLAB displays:

```
z =  
    9    9    9  
    9    9    9  
    9    9    9
```

To see the corresponding MEX-file C code `xtimesy.c`, open the file in MATLAB Editor.

As this example shows, creating MEX-file gateways that handle multiple inputs and outputs is straightforward. You must match the indices of the *prhs* and *plhs* vectors with the input and output arguments of your function. In the example above, the input variable `x` corresponds to *prhs*[0] and the input variable `y` to *prhs*[1].

The `mxGetScalar` function returns the value of `x`, rather than a pointer to `x`. This is just an alternative way of handling scalars. You could treat `x` as a 1-by-1 matrix and use `mxGetPr` to return a pointer to `x`.

Pass Structures and Cell Arrays

Passing structures and cell arrays into MEX-files is like passing any other data type, except the data itself is of type `mxArray`. In practice, this means that `mxGetField` (for structures) and `mxGetCell` (for cell arrays) return pointers of type `mxArray`. You treat the pointers like any other pointers of type `mxArray`, but if you want to pass the data contained in the `mxArray` to a C/C++ routine, you must use an API function such as `mxGetData` to access it.

This example takes an `m`-by-`n` structure matrix as input and returns a new 1-by-1 structure that contains these fields:

- String input generates an `m`-by-`n` cell array
- Numeric input (noncomplex, scalar values) generates an `m`-by-`n` vector of numbers with the same class ID as the input, for example, `int`, `double`, and so on.

To see the program `phonebook.c`, open the file in MATLAB Editor.

To build this example, at the command prompt type:

```
mex phonebook.c
```

To see how this program works, enter this structure:

```
friends(1).name = 'Jordan Robert';  
friends(1).phone = 3386;  
friends(2).name = 'Mary Smith';  
friends(2).phone = 3912;  
friends(3).name = 'Stacy Flora';  
friends(3).phone = 3238;  
friends(4).name = 'Harry Alpert';  
friends(4).phone = 3077;
```

The results of this input are:

```
phonebook(friends)  
  
ans =  
    name: {1x4 cell }
```

phone: [3386 3912 3238 3077]

Create 2-D Cell Array

This example, `mxcreatecellmatrix.c`, takes the input arguments and places them in a cell array. It then displays the contents through a `mexCallMATLAB` call. To see the program, open the file in MATLAB Editor.

Create input arguments.

```
str1 = 'hello';  
str2 = 'world';  
num = 2012;
```

Create a 3x1 cell array and call `disp` to display the contents.

```
mxcreatecellmatrix(str1,str2,num)
```

The contents of the created cell is:

```
'hello'  
'world'  
[2012]
```

Fill mxArray

You can move data from a C/C++ program into an mxArray using the MX Matrix Library. The functions you use depend on the type of data in your application. Use the `mxSetPr` and `mxGetPr` functions for data of type `double`. For numeric data other than `double`, use the `mxSetData` function. For nonnumeric data, see the examples on the `mxCreateString` function reference page.

The following examples use a variable *data* to represent data from a computational routine (described in “The Components of a C/C++ MEX-File” on page 4-2). Each example creates an mxArray using the `mxCreateNumericMatrix` function, fills it with *data*, and returns it as the output argument *plhs[0]*.

These examples use real data only. If you have complex data, use the `mxGetPi` and `mxSetPi` functions as needed.

Copying Data Directly into an mxArray

The `arrayFillGetPr.c` example uses the `mxGetPr` function to copy the values from *data* to *plhs[0]*. To see the example, open the file in MATLAB Editor.

Pointing to Data

The `arrayFillSetPr.c` example uses the `mxSetPr` function to point *plhs[0]* to *data*. To see the example, open the file in MATLAB Editor.

The example `arrayFillSetData.c` illustrates how to fill an mxArray for numeric types other than `double`. To see the example, open the file in MATLAB Editor.

Prompt User for Input

Because MATLAB does not use `stdin` and `stdout`, do not use C/C++ functions like `scanf` and `printf` to prompt for user input. The following example shows how to use `mexCallMATLAB` with the `input` function to get a number from the user.

```
#include "mex.h"
#include "string.h"
void mexFunction( int nlhs, mxArray *plhs[],
                  int nrhs, const mxArray *prhs[] )
{
    mxArray  *new_number, *str;
    double out;

    str = mxCreateString("Enter extension: ");
    mexCallMATLAB(1,&new_number,1,&str,"input");
    out = mxGetScalar(new_number);
    mexPrintf("You entered: %.0f ", out);
    mxDestroyArray(new_number);
    mxDestroyArray(str);
    return;
}
```

Handle Complex Data

MATLAB separates complex data into real and imaginary parts. The MATLAB API provides two functions, `mxGetPr` and `mxGetPi`, that return pointers (of type `double *`) to the real and imaginary parts of your data.

This example, `convec.c`, takes two complex row vectors and convolves them. To see the example, open the file in MATLAB Editor.

To build this example, at the command prompt type:

```
mex convec.c
```

Entering these numbers at the MATLAB prompt:

```
x = [3.000 - 1.000i, 4.000 + 2.000i, 7.000 - 3.000i];  
y = [8.000 - 6.000i, 12.000 + 16.000i, 40.000 - 42.000i];
```

and invoking the new MEX-file:

```
z = convec(x,y)
```

results in:

```
z =  
    1.0e+02 *
```

```
Columns 1 through 4
```

```
0.1800 - 0.2600i 0.9600 + 0.2800i 1.3200 - 1.4400i 3.7600 - 0.1200i
```

```
Column 5
```

```
1.5400 - 4.1400i
```

which agrees with the results from the built-in MATLAB function `conv`.

Handle 8-, 16-, and 32-Bit Data

The MATLAB API provides a set of functions that support signed and unsigned 8-, 16-, and 32-bit data. For example, the `mxCreateNumericArray` function constructs an unpopulated N-dimensional numeric array with a specified data size. For more information, see `mxClassID`.

Once you have created an unpopulated MATLAB array of a specified data type, you can access the data using `mxGetData` and `mxGetImagData`. These two functions return pointers to the real and imaginary data. You can perform arithmetic on data of 8-, 16-, or 32-bit precision in MEX-files and return the result to MATLAB, which recognizes the correct data class.

The example, `doubleelement.c`, constructs a 2-by-2 matrix with unsigned 16-bit integers, doubles each element, and returns both matrices to MATLAB. To see the example, open the file in MATLAB Editor.

To build this example, at the command prompt type:

```
mex doubleelement.c
```

At the MATLAB prompt, entering:

```
doubleelement
```

produces:

```
ans =  
     2     6  
     4     8
```

The output of this function is a 2-by-2 matrix populated with unsigned 16-bit integers.

Manipulate Multidimensional Numerical Arrays

You can manipulate multidimensional numerical arrays by using `mxGetData` and `mxGetImagData`. These functions return pointers to the real and imaginary parts of the data stored in the original multidimensional array. The example, `findnz.c`, takes an N-dimensional array of doubles and returns the indices for the nonzero elements in the array. To see the example, open the file in MATLAB Editor.

To build this example, at the command prompt type:

```
mex findnz.c
```

Entering a sample matrix at the MATLAB prompt gives:

```
matrix = [ 3 0 9 0; 0 8 2 4; 0 9 2 4; 3 0 9 3; 9 9 2 0]
matrix =
     3     0     9     0
     0     8     2     4
     0     9     2     4
     3     0     9     3
     9     9     2     0
```

This example determines the position of all nonzero elements in the matrix. Running the MEX-file on this matrix produces:

```
nz = findnz(matrix)
```

```
nz =
```

```
 1 1  
 4 1  
 5 1  
 2 2  
 3 2  
 5 2  
 1 3  
 2 3  
 3 3  
 4 3  
 5 3  
 2 4  
 3 4  
 4 4
```

Handle Sparse Arrays

The MATLAB API provides a set of functions that allow you to create and manipulate sparse arrays from within your MEX-files. These API routines access and manipulate `ir` and `jc`, two of the parameters associated with sparse arrays. For more information on how MATLAB stores sparse arrays, see “The MATLAB Array” on page 3-18.

The example, `fulltosparse.c`, illustrates how to populate a sparse matrix. To see the example, open the file in MATLAB Editor.

To build this example, at the command prompt type:

```
mex fulltosparse.c
```

At the MATLAB prompt, entering:

```
full = eye(5)
full =
     1     0     0     0     0
     0     1     0     0     0
     0     0     1     0     0
     0     0     0     1     0
     0     0     0     0     1
```

creates a full, 5-by-5 identity matrix. Using `fulltosparse` on the full matrix produces the corresponding sparse matrix.

```
spar = fulltosparse(full)
spar =
(1,1)      1
(2,2)      1
(3,3)      1
(4,4)      1
(5,5)      1
```

Call MATLAB Functions from C/C++ MEX-Files

It is possible to call MATLAB functions, operators, user-defined functions, and other binary MEX-files from within your C/C++ source code by using the API function `mexCallMATLAB`.

The example, `sincall.c`, creates an `mxArray`, passes various pointers to a local function to acquire data, and calls `mexCallMATLAB` to calculate the `sine` function and plot the results. To see the example, open the file in MATLAB Editor.

To build this example, at the command prompt type:

```
mex sincall.c
```

Running this example:

```
sincall
```

displays a sin curve equivalent to executing the following MATLAB commands:

```
MAX=1000;  
  
mm = MAX/2;  
for i=1:mm-1  
    X(i)=i*(4*3.14159/MAX);  
end  
  
Y = sin(X);  
plot(X,Y)
```

Use C++ Features in MEX-Files

This example, `mexcpp.cpp`, illustrates how to use C++ code with your C language MEX-file. It uses member functions, constructors, destructors, and the `iostream` include file. To see the example, open the file in MATLAB Editor.

To build this example, at the command prompt type:

```
mex mexcpp.cpp
```

The calling syntax is `mexcpp(num1, num2)`.

The routine defines a class, *myData*, with member functions `display` and `set_data`, and variables *v1* and *v2*. It constructs an object `d` of class *myData* and displays the initialized values of *v1* and *v2*. It then sets *v1* and *v2* to your input, *num1* and *num2*, and displays the new values. Finally, the `delete` operator cleans up the object.

Handle Files with C++

This example, `mexatexit.cpp`, illustrates C++ file handling features. To see the C++ code, open the C++ file in MATLAB Editor. To compare it with a C code example `mexatexit.c`, open this file in MATLAB Editor.

C Example

The C code example registers the `mexAtExit` function to perform cleanup tasks (close the data file) when the MEX-file clears. This example prints a message on the screen (using `mexPrintf`) when performing file operations `fopen`, `fprintf`, and `fclose`.

To build the MEX-file, type:

```
mex mexatexit.c
```

If you type:

```
x = 'my input string';  
mexatexit(x)
```

MATLAB displays:

```
Opening file matlab.data.  
Writing data to file.
```

To clear the MEX-file, type:

```
clear mexatexit
```

MATLAB displays:

```
Closing file matlab.data.
```

You can see the contents of `matlab.data` by typing:

```
type matlab.data
```

MATLAB displays:

```
my input string
```

C++ Example

The C++ example does not use the `mexAtExit` function. A `fileresource` class handles the file open and close functions. The MEX-file calls the destructor for this class (which closes the data file). This example also prints a message on the screen when performing operations on the data file. However, in this case, the only C file operation performed is the write operation, `fprintf`.

To build the `mexatexit.cpp` MEX-file, make sure that you have selected a C++ compiler, then type:

```
mex mexatexit.cpp
```

If you type:

```
z = 'for the C++ MEX-file';  
mexatexit(x)  
mexatexit(z)  
clear mexatexit
```

MATLAB displays:

```
Writing data to file.  
Writing data to file.
```

To see the contents of `matlab.data`, type:

```
type matlab.data
```

MATLAB displays:

```
my input string  
for the C++ MEX-file
```

Debug C/C++ Language MEX-Files

In this section...
“Notes on Debugging” on page 4-32
“Debugging on the Microsoft Windows Platforms” on page 4-32
“Debugging on Linux Platforms” on page 4-40

Notes on Debugging

The examples show how to debug `yprime.c`, found in your `matlabroot/extern/examples/mex/` folder.

Binary MEX-files built with the `-g` option do not execute on other computers because they rely on files that are not distributed with MATLAB software. For additional information on isolating problems with MEX-files, see “Troubleshoot MEX-Files”.

Debugging on the Microsoft Windows Platforms

The Microsoft Visual Studio development environment provides complete source code debugging, including the ability to set breakpoints, examine variables, and step through the source code line-by-line.

Visual Studio 2005

This section describes how to debug using Visual Studio.

- 1 Select the Microsoft Visual C++ 2005 compiler. At the MATLAB prompt, type:

```
mex -setup
```

Type `y` to locate installed compilers, and then type the number corresponding to this compiler.

- 2 Next, compile the source MEX-file with the `-g` option, which builds the file with debugging symbols included. For example:

```
copyfile(fullfile(matlabroot,'extern','examples','mex',...
```

```
'yprime.c'), fullfile('c:', 'work'));  
mex -g yprime.c
```

On a 32-bit platform, this command creates the executable file `yprime.mexw32`.

- 3** Start Visual Studio. Do not exit your MATLAB session.

4 From the Visual Studio **Tools** menu, select **Attach to Process...**¹

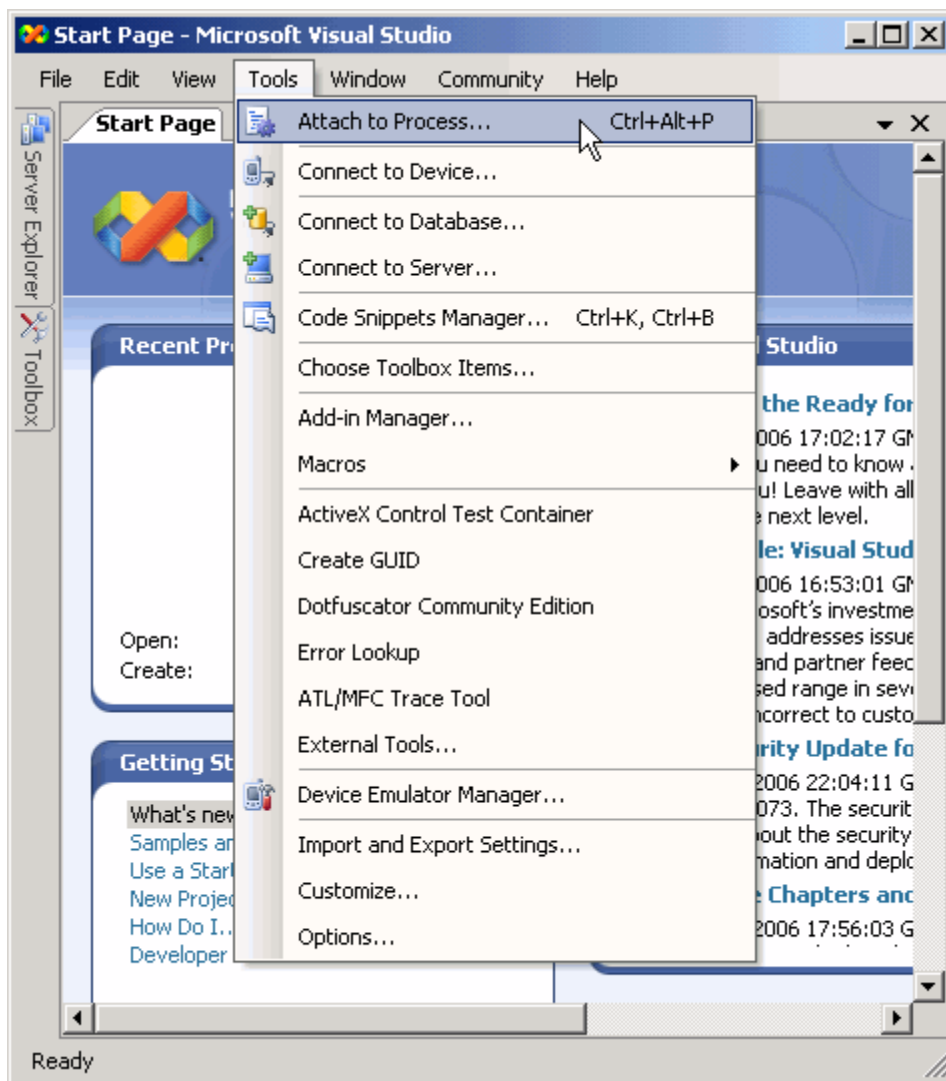

1. used by permission

- 5 In the Attach to Process dialog box, select the MATLAB process and click **Attach**.

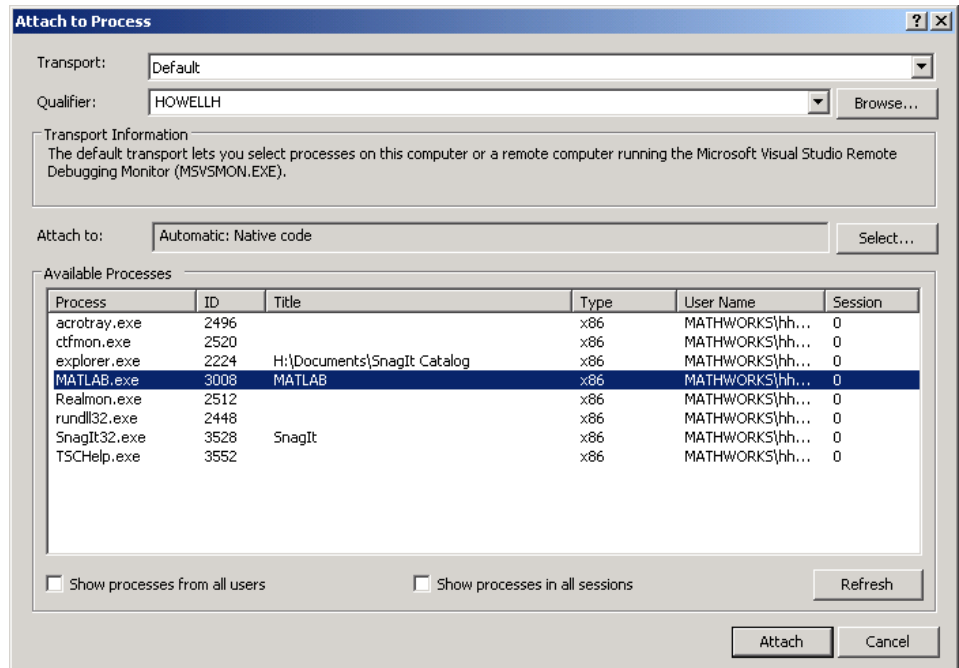

Visual Studio loads data then displays an empty code pane.

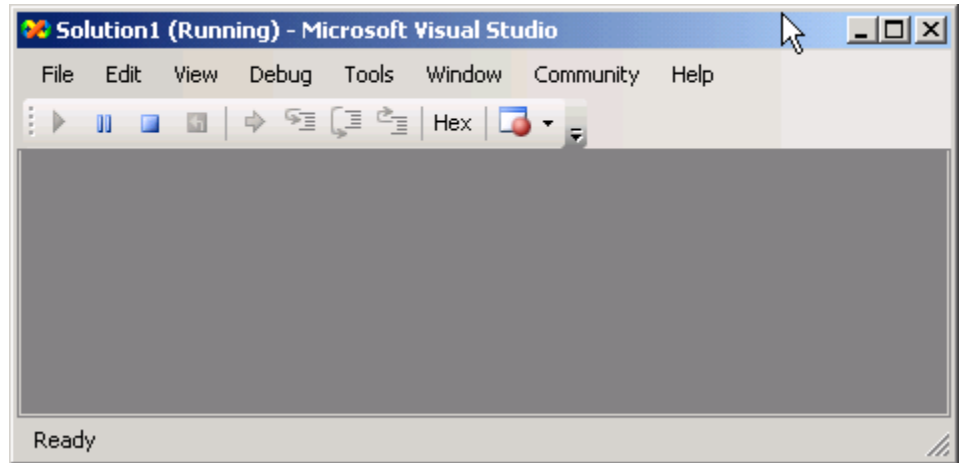

- 6 Open the source file `yprime.c` by selecting **File > Open > File**. `yprime.c` is found in the `matlabroot/extern/examples/mex/` folder.

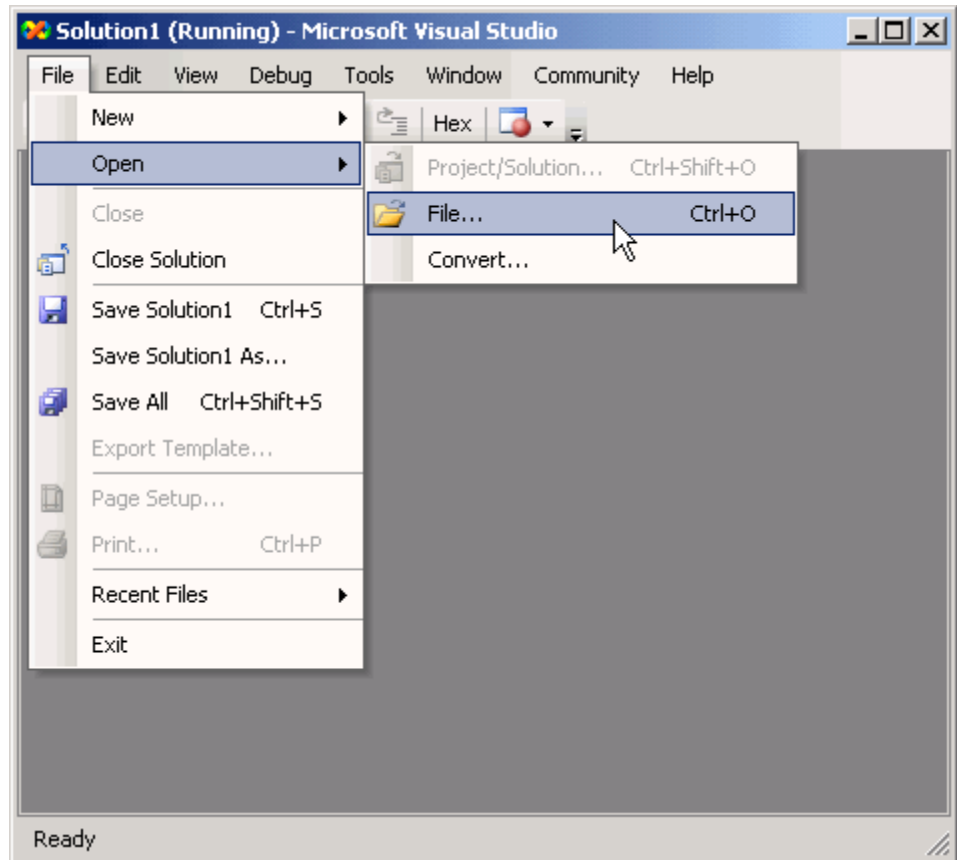

- 7 Set a breakpoint by right-clicking the desired line of code and following **Breakpoint > Insert Breakpoint** on the context menu. It is often

convenient to set a breakpoint at `mexFunction` to stop at the beginning of the gateway routine.

If you have not yet run the executable file, ignore any “!” icon that appears with the breakpoint next to the line of code.

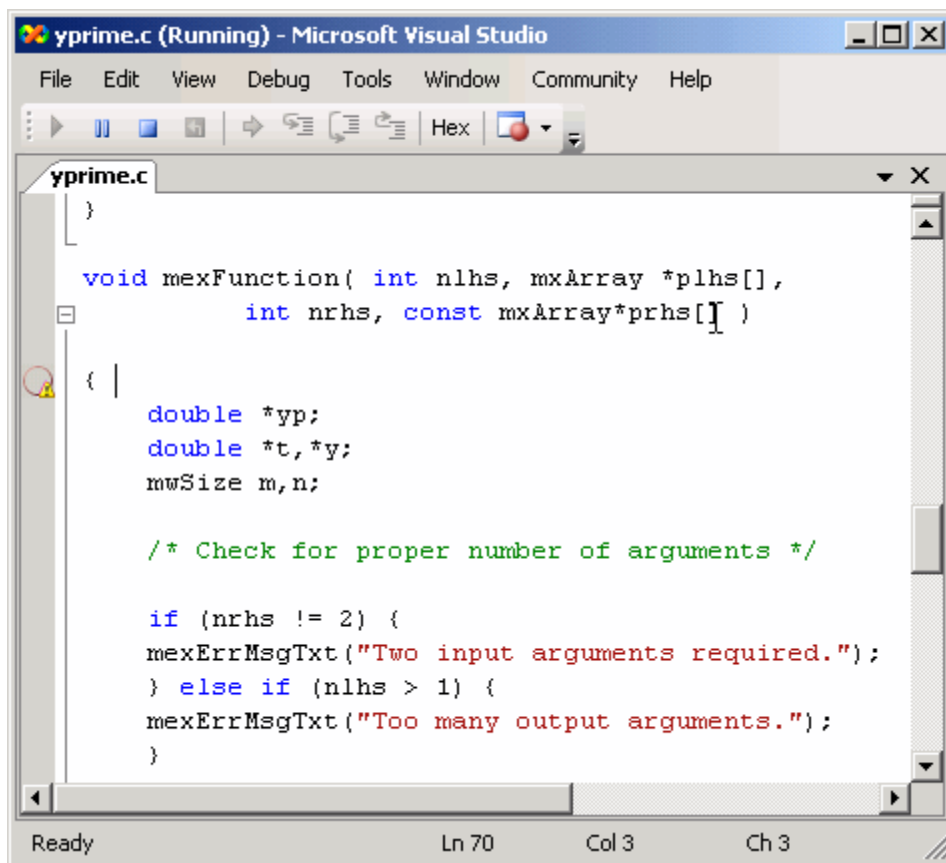

```
yprime.c (Running) - Microsoft Visual Studio
File Edit View Debug Tools Window Community Help
Hex
yprime.c
}
void mexFunction( int nlhs, mxArray *plhs[],
                 int nrhs, const mxArray*prhs[] )
{
    double *yp;
    double *t,*y;
    mwSize m,n;

    /* Check for proper number of arguments */

    if (nrhs != 2) {
        mexErrMsgTxt("Two input arguments required.");
    } else if (nlhs > 1) {
        mexErrMsgTxt("Too many output arguments.");
    }
}
Ready Ln 70 Col 3 Ch 3
```

Once you hit one of your breakpoints, you can make full use of any commands the debugger provides to examine variables, display memory, or inspect registers.

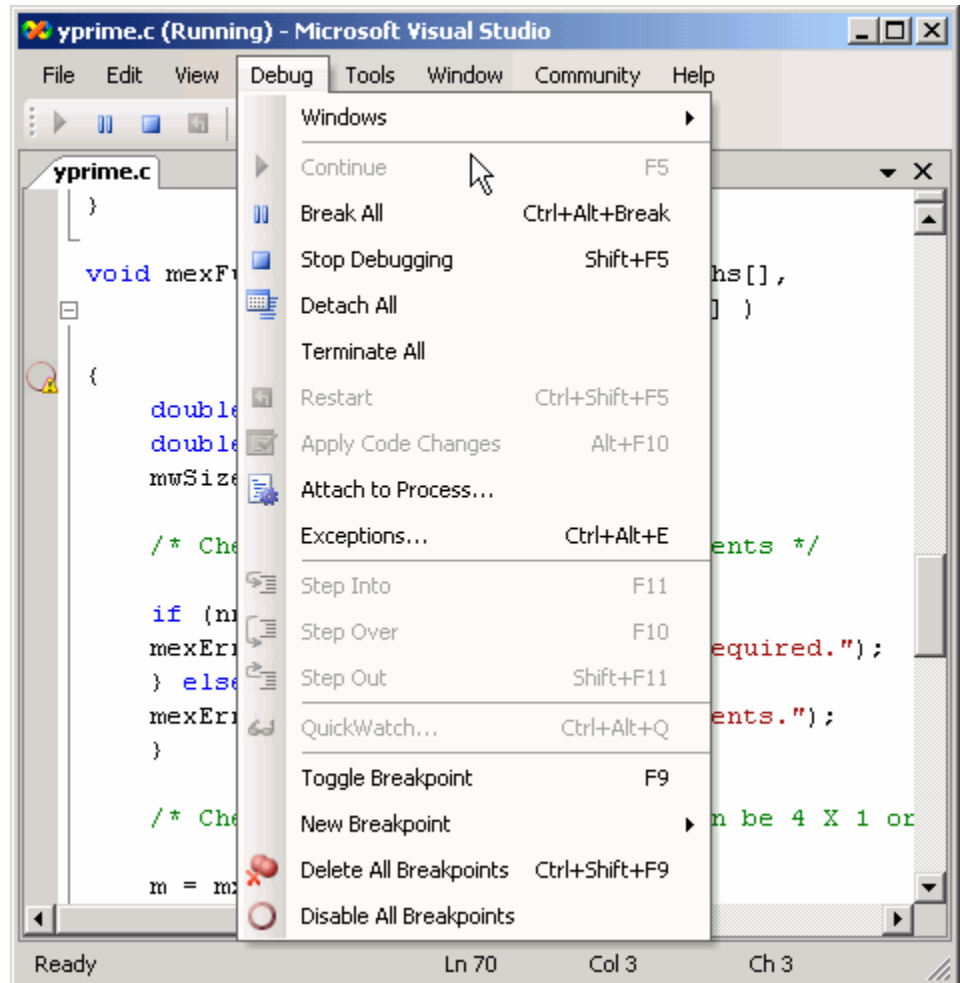

8 Run the binary MEX-file in MATLAB. After typing:

```
yprime(1,1:4)
```

yprime.c is opened in the Visual Studio debugger at the first breakpoint.

- 9** If you select **Debug > Continue**, MATLAB displays:

```
ans =  
  
    2.0000    8.9685    4.0000   -1.0947
```

For more information on how to debug in the Visual Studio environment, see your Microsoft documentation.

Debugging on Linux Platforms

The GNU® Debugger gdb, available on Linux systems, provides complete source code debugging, including the ability to set breakpoints, examine variables, and step through the source code line-by-line.

GNU Debugger gdb

In this procedure, the MATLAB command prompt `>>` is shown in front of MATLAB commands, and `linux>` represents a Linux prompt; your system may show a different prompt. The debugger prompt is `<gdb>`.

To debug with gdb:

- 1** Compile the source MEX-file with the `-g` option, which builds the file with debugging symbols included. For this example, at the Linux prompt, type:

```
linux> mex -g yprime.c
```

- 2** At the Linux prompt, start the gdb debugger using the `matlab -D` option:

```
linux> matlab -Dgdb
```

- 3** Start MATLAB without the Java® Virtual Machine (JVM™) by using the `-nojvm` startup flag:

```
<gdb> run -nojvm
```

- 4** In MATLAB, enable debugging with the `dbmex` function and run your binary MEX-file:

```
>> dbmex on
>> yprime(1,1:4)
```

5 At this point, you are ready to start debugging.

It is often convenient to set a breakpoint at `mexFunction` so you stop at the beginning of the gateway routine.

```
<gdb> break mexFunction
<gdb> continue
```

6 Once you hit one of your breakpoints, you can make full use of any commands the debugger provides to examine variables, display memory, or inspect registers.

To proceed from a breakpoint, type:

```
<gdb> continue
```

7 After stopping at the last breakpoint, type:

```
<gdb> continue
```

`yprime` finishes and MATLAB displays:

```
ans =
      2.0000      8.9685      4.0000     -1.0947
```

8 From the MATLAB prompt you can return control to the debugger by typing:

```
>> dbmex stop
```

Or, if you are finished running MATLAB, type:

```
>> quit
```

9 When you are finished with the debugger, type:

```
<gdb> quit
```

You return to the Linux prompt.

Refer to the documentation provided with your debugger for more information on its use.

Handling Large mxArray

In this section...
“Using the 64-Bit API” on page 4-43
“Building the Binary MEX-File” on page 4-45
“Example” on page 4-45
“Caution Using Negative Values” on page 4-46
“Building Cross-Platform Applications” on page 4-46

Binary MEX-files built on 64-bit platforms can handle 64-bit mxArray. These large data arrays can have up to $2^{48}-1$ elements. The maximum number of elements a sparse mxArray can have is $2^{48}-2$.

Using the following instructions creates platform-independent binary MEX-files as well.

Your system configuration can impact the performance of MATLAB. The 64-bit processor requirement enables you to create the mxArray and access data in it. However, your system’s memory, in particular the size of RAM and virtual memory, determine the speed at which MATLAB processes the mxArray. The more memory available, the faster the processing.

The amount of RAM also limits the amount of data you can process at one time in MATLAB. For guidance on memory issues, see “Strategies for Efficient Use of Memory” in the Programming Fundamentals documentation. Memory management within source MEX-files can have special considerations, as described in “Memory Management” on page 4-47.

Using the 64-Bit API

The signatures of the API functions shown in the following table use the mwSize or mwIndex types to work with a 64-bit mxArray. The variables you use in your source code to call these functions must be the correct type.

mxArray Functions Using mwSize/mwIndex

mxCalcSingleSubscript	mxCreateSparseLogicalMatrix ²
mxCalloc	mxCreateStructArray
mxCopyCharacterToPtr ¹	mxCreateStructMatrix
mxCopyComplex16ToPtr ¹	mxGetCell
mxCopyComplex8ToPtr ¹	mxGetDimensions
mxCopyInteger1ToPtr ¹	mxGetElementSize
mxCopyInteger2ToPtr ¹	mxGetField
mxCopyInteger4ToPtr ¹	mxGetFieldByNumber
mxCopyPtrToCharacter ¹	mxGetIr
mxCopyPtrToComplex16 ¹	mxGetJc
mxCopyPtrToComplex8 ¹	mxGetM
mxCopyPtrToInteger1 ¹	mxGetN
mxCopyPtrToInteger2 ¹	mxGetNumberOfDimensions
mxCopyPtrToInteger4 ¹	mxGetNumberOfElements
mxCopyPtrToPtrArray ¹	mxGetNzmax
mxCopyPtrToReal4 ¹	mxGetProperty
mxCopyPtrToReal8 ¹	mxGetString
mxCopyReal4ToPtr ¹	mxMalloc
mxCopyReal8ToPtr ¹	mxRealloc
mxCreateCellArray	mxSetCell
mxCreateCellMatrix	mxSetDimensions
mxCreateCharArray	mxSetField
mxCreateCharMatrixFromStrings	mxSetFieldByNumber
mxCreateDoubleMatrix	mxSetIr
mxCreateLogicalArray ²	mxSetJc
mxCreateLogicalMatrix ²	mxSetM
mxCreateNumericArray	mxSetN

mxArray Functions Using mwSize/mwIndex (Continued)

<code>mxCreateNumericMatrix</code>	<code>mxSetNzmax</code>
<code>mxCreateSparse</code>	<code>mxSetProperty</code>

¹Fortran function only

²C function only

Functions in this API use the `mwIndex` and `mwSize` types. For information about using these macros, see “Required Header Files” on page 4-4.

Building the Binary MEX-File

Use the `mex` build script option `-largeArrayDims` with the 64-bit API.

Example

The example, `arraySize.c` in `matlabroot/extern/examples/mex`, illustrates memory requirements of large mxArray. To see the example, open the file in MATLAB Editor.

This function requires one positive scalar numeric input, which it uses to create a square matrix. It checks the size of the input to make sure your system can theoretically create a matrix of this size. If the input is valid, it displays the size of the mxArray in kilobytes.

To build this MEX-file, type:

```
mex -largeArrayDims arraySize.c
```

To run the MEX-file, type:

```
arraySize(2^10)
```

If your system has enough available memory, MATLAB displays:

```
Dimensions: 1024 x 1024
Size of array in kilobytes: 1024
```

If your system does not have enough memory to create the array, MATLAB displays an `Out of memory` error.

You can experiment with this function to test the performance and limits of handling large arrays on your system.

Caution Using Negative Values

When using the 64-bit API, `mwSize` and `mwIndex` are equivalent to `size_t` in C/C++. This type is unsigned, unlike `int`, which is the type used in the 32-bit API. Be careful not to pass any negative values to functions that take `mwSize` or `mwIndex` arguments. Do not cast negative `int` values to `mwSize` or `mwIndex`; the returned value cannot be predicted. Instead, change your code to avoid using negative values.

Building Cross-Platform Applications

If you develop cross-platform applications (programs that can run on both 32- and 64-bit architectures), you must pay attention to the upper limit of values you use for `mwSize` and `mwIndex`. The 32-bit application reads these values and assigns them to variables declared as `int` in C/C++. Be careful to avoid assigning a large `mwSize` or `mwIndex` value to an `int` or other variable that might be too small.

Memory Management

In this section...

“Automatic Cleanup of Temporary Arrays” on page 4-47

“Persistent Arrays” on page 4-48

Memory management in MEX-files is similar to memory management in any C/C++ or Fortran application. However, there are special considerations because a binary MEX-file exists within the context of a larger application, MATLAB.

To avoid common problems related to memory management, see “Memory Management Issues” on page 3-97.

Automatic Cleanup of Temporary Arrays

When a binary MEX-file returns control to MATLAB, it returns the results of its computations in the output arguments—the `mxArrays` contained in the left-hand side arguments `p1hs[]`. MATLAB destroys any `mxArray` created by the MEX-file that is not in this argument list. In addition, MATLAB frees any memory that was allocated in the MEX-file using the `mxMalloc`, `mxRealloc`, or `mxRealloc` functions.

MathWorks recommends that MEX-file functions destroy their own temporary arrays and free their own dynamically allocated memory. It is more efficient to perform this cleanup in the source MEX-file than to rely on the automatic mechanism. However, there are several circumstances in which the MEX-file does not reach its normal return statement.

The normal return is not reached if:

- A call to `mexErrMsgTxt` occurs.
- A call to `mexCallMATLAB` occurs and the function being called creates an error. (A source MEX-file can trap such errors by using the `mexCallMATLABWithTrap` function, but not all MEX-files necessarily need to trap errors.)
- The user interrupts the binary MEX-file’s execution using **Ctrl+C**.

- The binary MEX-file runs out of memory. When this happens, the MATLAB out-of-memory handler immediately terminates the MEX-file.

A careful MEX-file programmer can ensure safe cleanup of all temporary arrays and memory before returning in the first two cases, but not in the last two cases. In the last two cases, the automatic cleanup mechanism is necessary to prevent memory leaks.

Persistent Arrays

You can exempt an array, or a piece of memory, from the MATLAB automatic cleanup by calling `mexMakeArrayPersistent` or `mexMakeMemoryPersistent`. However, if a binary MEX-file creates such persistent objects, there is a danger that a memory leak could occur if the MEX-file is cleared before the persistent object is properly destroyed. To prevent this from happening, a source MEX-file that creates persistent objects should register a function, using the `mexAtExit` function, which disposes of the objects. (You can use a `mexAtExit` function to dispose of other resources as well; for example, you can use `mexAtExit` to close an open file.)

For example, here is a simple source MEX-file that creates a persistent array and properly disposes of it.

```
#include "mex.h"

static int initialized = 0;
static mxArray *persistent_array_ptr = NULL;

void cleanup(void) {
    mexPrintf("MEX-file is terminating, destroying array\n");
    mxDestroyArray(persistent_array_ptr);
}

void mexFunction(int nlhs,
                 mxArray *plhs[],
                 int nrhs,
                 const mxArray *prhs[])
{
    if (!initialized) {
        mexPrintf("MEX-file initializing, creating array\n");
```

```
/* Create persistent array and register its cleanup. */
persistent_array_ptr = mxCreateDoubleMatrix(1, 1, mxREAL);
mexMakeArrayPersistent(persistent_array_ptr);
mexAtExit(cleanup);
initialized = 1;

/* Set the data of the array to some interesting value. */
*mxGetPr(persistent_array_ptr) = 1.0;
} else {
    mexPrintf("MEX-file executing; value of first array element is %g\n",
              *mxGetPr(persistent_array_ptr));
}
}
```

Handling Large File I/O

In this section...

“Prerequisites to Using 64-Bit I/O” on page 4-50

“Specifying Constant Literal Values” on page 4-52

“Opening a File” on page 4-53

“Printing Formatted Messages” on page 4-54

“Replacing fseek and ftell with 64-Bit Functions” on page 4-54

“Determining the Size of an Open File” on page 4-55

“Determining the Size of a Closed File” on page 4-56

Prerequisites to Using 64-Bit I/O

MATLAB supports the use of 64-bit file I/O operations in your MEX-file programs. This enables you to read and write data to files that are up to and greater than 2 GB (2^{31-1} bytes) in size. Note that some operating systems or compilers might not support files larger than 2 GB. This section describes the components you need to use 64-bit file I/O in your MEX-file programs:

- “Header File” on page 4-50
- “Type Declarations” on page 4-51
- “Functions” on page 4-51

Header File

Header file `io64.h` defines many of the types and functions required for 64-bit file I/O. The statement to include this file must be the *first* `#include` statement in your source file and must also precede any system header include statements:

```
#include "io64.h"  
#include "mex.h"
```

Type Declarations

Use the following types to declare variables used in 64-bit file I/O.

MEX Type	Description	POSIX
<code>fpos_T</code>	Declares a 64-bit int type for <code>setFilePos()</code> and <code>getFilePos()</code> . Defined in <code>io64.h</code> .	<code>fpos_t</code>
<code>int64_T</code> , <code>uint64_T</code>	Declares 64-bit signed and unsigned integer types. Defined in <code>tmwtypes.h</code> .	<code>long</code> , <code>long</code>
<code>structStat</code>	Declares a structure to hold the size of a file. Defined in <code>io64.h</code> .	<code>struct stat</code>
<code>FMT64</code>	Used in <code>mexPrintf</code> to specify length within a format specifier such as <code>%d</code> . See example in the section “Printing Formatted Messages” on page 4-54. <code>FMT64</code> is defined in <code>tmwtypes.h</code> .	<code>%lld</code>
<code>LL</code> , <code>LLU</code>	Suffixes for literal int constant 64-bit values (C Standard ISO/IEC 9899:1999(E) Section 6.4.4.1). Used only on UNIX systems.	<code>LL</code> , <code>LLU</code>

Functions

Use the following functions for 64-bit file I/O. All are defined in the header file `io64.h`.

Function	Description	POSIX
<code>fileno()</code>	Gets a file descriptor from a file pointer	<code>fileno()</code>
<code>fopen()</code>	Opens the file and obtains the file pointer	<code>fopen()</code>
<code>getFileFstat()</code>	Gets the file size of a given file pointer	<code>fstat()</code>
<code>getFilePos()</code>	Gets the file position for the next I/O	<code>fgetpos()</code>
<code>getFileStat()</code>	Gets the file size of a given file name	<code>stat()</code>
<code>setFilePos()</code>	Sets the file position for the next I/O	<code>fsetpos()</code>

Specifying Constant Literal Values

To assign signed and unsigned 64-bit integer literal values, use type definitions `int64_T` and `uint64_T`.

On UNIX systems, to assign a literal value to an integer variable where the value to be assigned is greater than $2^{31} - 1$ signed, you must suffix the value with `LL`. If the value is greater than $2^{32} - 1$ unsigned, then use `LLU` as the suffix. These suffixes apply only to UNIX systems and are considered invalid on the Microsoft Windows systems.

Note The `LL` and `LLU` suffixes are not required for hardcoded (literal) values less than 2^{31} ($2^{31} - 1$), even if they are assigned to a 64-bit `int` type.

The following example declares a 64-bit integer variable initialized with a large literal `int` value, and two 64-bit integer variables:

```
void mexFunction(int nlhs, mxArray *plhs[], int nrhs,
                 const mxArray *prhs[])
{
    #if defined(_MSC_VER) || defined(__BORLANDC__)    /* Windows */
```

```

        int64_T large_offset_example = 9000222000;
#else                                     /* UNIX    */
        int64_T large_offset_example = 9000222000LL;
#endif

int64_T offset = 0;
int64_T position = 0;

```

Opening a File

To open a file for reading or writing, use the C/C++ `fopen` function as you normally would. As long as you have included `io64.h` at the start of your program, `fopen` works correctly for large files. No changes at all are required for `fread`, `fwrite`, `fprintf`, `fscanf`, and `fclose`.

To open an existing file for read and update in binary mode:

```

fp = fopen(filename, "r+b");
if (NULL == fp)
{
    /* File does not exist. Create new file for writing
     * in binary mode.
     */
    fp = fopen(filename, "wb");
    if (NULL == fp)
    {
        sprintf(str, "Failed to open/create test file '%s'",
                filename);
        mexErrMsgTxt(str);
        return;
    }
    else
    {
        mexPrintf("New test file '%s' created\n",filename);
    }
}
else mexPrintf("Existing test file '%s' opened\n",filename);

```

Printing Formatted Messages

You cannot print 64-bit integers using the `%d` conversion specifier. Instead, use `FMT64` to specify the appropriate format for your platform. `FMT64` is defined in the header file `tmwtypes.h`. The following example shows how to print a message showing the size of a large file:

```
int64_T large_offset_example = 9000222000LL;

mexPrintf("Example large file size: %" FMT64 "d bytes.\n",
          large_offset_example);
```

Replacing `fseek` and `ftell` with 64-Bit Functions

The ANSI C `fseek` and `ftell` functions are not 64-bit file I/O capable on most platforms. The functions `setFilePos` and `getFilePos`, however, are defined as the corresponding POSIX `fsetpos` and `fgetpos`, (or `fsetpos64` and `fgetpos64`), as required by your platform/OS. These functions are 64-bit file I/O capable on all platforms.

The following example shows how to use `setFilePos` instead of `fseek`, and `getFilePos` instead of `ftell`. It uses `getFileFstat` to find the size of the file, and then uses `setFilePos` to seek to the end of the file to prepare for adding data at the end of the file.

Note Although the `offset` parameter to `setFilePos` and `getFilePos` is really a pointer to a signed 64-bit integer, `int64_T`, it must be cast to an `fpos_T*`. The `fpos_T` type is defined in `io64.h` as the appropriate `fpos64_t` or `fpos_t`, as required by your platform/OS.

```
getFileFstat(fileno(fp), &statbuf);
fileSize = statbuf.st_size;
offset = fileSize;

setFilePos(fp, (fpos_T*) &offset);
getFilePos(fp, (fpos_T*) &position );
```

Unlike `fseek`, `setFilePos` supports only absolute seeking relative to the beginning of the file. If you want to do a relative seek, first call `getFileFstat`

to obtain the file size, and then convert the relative offset to an absolute offset that you can pass to `setFilePos`.

Determining the Size of an Open File

To get the size of an open file:

- Refresh the record of the file size stored in memory using `getFilePos` and `setFilePos`.
- Retrieve the size of the file using `getFileFstat`.

Refreshing the File Size Record

Before attempting to retrieve the size of an open file, you should first refresh the record of the file size residing in memory. If you skip this step on a file that is opened for writing, the file size returned might be incorrect or 0.

To refresh the file size record, seek to any offset in the file using `setFilePos`. If you do not want to change the position of the file pointer, you can seek to the current position in the file. This example obtains the current offset from the start of the file, and then seeks to the current position to update the file size without moving the file pointer:

```
getFilePos( fp, (fpos_T*) &position);
setFilePos( fp, (fpos_T*) &position);
```

Getting the File Size

The `getFileFstat` function takes a file descriptor input argument (that you can obtain from the file pointer of the open file using `fileno`) and returns the size of that file in bytes in the `st_size` field of a `structStat` structure:

```
structStat statbuf;
int64_T fileSize = 0;

if (0 == getFileFstat(fileno(fp), &statbuf))
{
    fileSize = statbuf.st_size;
    mexPrintf("File size is %" FMT64 "d bytes\n", fileSize);
}
```

Determining the Size of a Closed File

The `getFileStat` function takes the file name of a closed file as an input argument and returns the size of the file in bytes in the `st_size` field of a `structStat` structure:

```
structStat statbuf;
int64_T fileSize = 0;

if (0 == getFileStat(filename, &statbuf))
{
    fileSize = statbuf.st_size;
    mexPrintf("File size is %" FMT64 "d bytes\n", fileSize);
}
```

Fortran MEX-Files

- “Fortran Source MEX-Files” on page 5-2
- “Set Up Fortran Examples” on page 5-12
- “Pass Scalar Values” on page 5-13
- “Pass Strings” on page 5-14
- “Pass Arrays of Strings” on page 5-15
- “Pass Matrices” on page 5-16
- “Pass Integers” on page 5-17
- “Pass Multiple Inputs or Outputs” on page 5-18
- “Handle Complex Data” on page 5-19
- “Dynamically Allocate Memory” on page 5-20
- “Handle Sparse Matrices” on page 5-21
- “Call MATLAB Functions from Fortran MEX-Files” on page 5-22
- “Debug Fortran Source MEX-Files” on page 5-24
- “Handling Large mxArray’s” on page 5-27
- “Memory Management” on page 5-30

Fortran Source MEX-Files

In this section...
“The Components of a Fortran MEX-File” on page 5-2
“Gateway Routine” on page 5-2
“Computational Routine” on page 5-5
“Preprocessor Macros” on page 5-5
“Using the Fortran %val Construct” on page 5-6
“Data Flow in MEX-Files” on page 5-7

The Components of a Fortran MEX-File

You create binary MEX-files using the `mex` build script. `mex` compiles and links source MEX-file files into a shared library called a binary MEX-file, which you can run from the MATLAB command line. Once compiled, you treat binary MEX-files like MATLAB functions.

This section explains the components of a source MEX-file, statements you use in a program source file. Unless otherwise specified, the term “MEX-file” refers to a source file.

The MEX-file consists of:

- A “Gateway Routine” on page 5-2 that interfaces Fortran and MATLAB data.
- A “Computational Routine” on page 5-5 that performs the computations you want implemented in the binary MEX-file.
- “Preprocessor Macros” on page 5-5 for building platform-independent code.

Gateway Routine

The *gateway routine* is the entry point to the MEX-file shared library. It is through this routine that MATLAB accesses the rest of the routines in your MEX-files. Use the following guidelines to create a gateway routine:

- “Naming the Gateway Routine” on page 5-3

- “Required Parameters” on page 5-3
- “Creating and Using Source Files” on page 5-4
- “Using MATLAB Libraries” on page 5-4
- “Required Header Files” on page 5-4
- “Naming the MEX-File” on page 5-5

A Fortran MEX-file gateway routine looks like this:

```
C      The gateway routine.
      subroutine mexFunction(nlhs, plhs, nrhs, prhs)
      integer nlhs, nrhs
      mwpointer plhs(*), prhs(*)
```

Naming the Gateway Routine

The name of the gateway routine must be `mexFunction`.

Required Parameters

A gateway routine must contain the parameters *prhs*, *nrhs*, *plhs*, and *nlhs* described in the following table.

Parameter	Description
<i>prhs</i>	An array of right-hand input arguments.
<i>plhs</i>	An array of left-hand output arguments.
<i>nrhs</i>	The number of right-hand arguments, or the size of the <i>prhs</i> array.
<i>nlhs</i>	The number of left-hand arguments, or the size of the <i>plhs</i> array.

Declare *prhs* and *plhs* as type `mxArray *`, which means they point to MATLAB arrays. They are vectors that contain pointers to the arguments of the MEX-file.

You can think of the name *prhs* as representing the “parameters, right-hand side,” that is, the input parameters. Likewise, *plhs* represents the “parameters, left-hand side,” or output parameters.

Creating and Using Source Files

It is good practice to write the gateway routine to call a “Computational Routine” on page 4-5; however, this is not required. The computational code can be part of the gateway routine. If you use both gateway and computational routines, you can combine them into one source file or into separate files. If you use separate files, the gateway routine must be the first source file listed in the `mex` command.

The name of the file containing your gateway routine is important, as explained in “Naming the MEX-File” on page 5-5.

Name your Fortran source file with an uppercase `.F` file extension.

The Difference Between `.f` and `.F` Files. Fortran compilers assume source files using a lowercase `.f` file extension have been preprocessed. On most platforms, `mex` makes sure the file is preprocessed regardless of the file extension. However, on Apple Macintosh platforms, `mex` cannot force preprocessing. Use an uppercase `.F` file extension to ensure your Fortran MEX-file is platform independent.

Using MATLAB Libraries

The MX Matrix Library and the MEX Library describe functions you can use in your gateway and computational routines that interact with MATLAB programs and the data in the MATLAB workspace. The MX Matrix Library functions provide access methods for manipulating MATLAB arrays. The MEX Library functions perform operations in the MATLAB environment.

Required Header Files

To use the functions in the C/C++ and Fortran API Reference library you must include the `fintrf` header file, which declares the entry point and interface routines. Put this statement in your source file:

```
#include "fintrf.h"
```

Naming the MEX-File

The binary MEX-file name, and hence the name of the function you use in MATLAB, is the name of the source file containing your gateway routine.

The file extension of the binary MEX-file is platform-dependent. You find the file extension using the `mexext` function, which returns the value for the current machine.

Computational Routine

The *computational routine* contains the code for performing the computations you want implemented in the binary MEX-file. Computations can be numerical computations as well as inputting and outputting data. The gateway calls the computational routine as a subroutine.

The programming requirements described in “Creating and Using Source Files” on page 4-4, “Using MATLAB Libraries” on page 4-4, and “Required Header Files” on page 4-4 might also apply to your computational routine.

Preprocessor Macros

The MX Matrix and MEX libraries use the MATLAB *preprocessor macros* `mwSize` and `mwIndex` for cross-platform flexibility. `mwSize` represents size values, such as array dimensions and number of elements. `mwIndex` represents index values, such as indices into arrays.

MATLAB has an additional preprocessor macro for Fortran files, `mwPointer`. MATLAB uses a unique data type, the `mxAarray`. Because you cannot create a new data type in Fortran, MATLAB passes a special identifier, created by the `mwPointer` preprocessor macro, to a Fortran program. This is how you get information about an `mxAarray` in a native Fortran data type. For example, you can find out the size of the `mxAarray`, determine whether or not it is a string, and look at the contents of the array. Use `mwPointer` to build platform-independent code.

The Fortran preprocessor converts `mwPointer` to `integer*4` when building binary MEX-files on 32-bit platforms and to `integer*8` when building on 64-bit platforms.

Note Declaring a pointer to be the incorrect size may cause your program to crash.

Using the Fortran %val Construct

The Fortran `%val(arg)` construct specifies that an argument, *arg*, is to be passed by value, instead of by reference. The `%val` construct is supported by most, but not all, Fortran compilers.

If your compiler does not support the `%val` construct, you must copy the array values into a temporary true Fortran array using the `mxCopy*` routines (for example, `mxCopyPtrToReal8`).

A %val Construct Example

If your compiler supports the `%val` construct, you can use routines that point directly to the data (that is, the pointer returned by `mxGetPr` or `mxGetPi`). You can use `%val` to pass this pointer's contents to a subroutine, where it is declared as a Fortran double-precision matrix.

For example, consider a gateway routine that calls its computational routine, `yprime`, by:

```
call yprime(%val(ypr), %val(tr), %val(yr))
```

If your Fortran compiler does not support the `%val` construct, you would replace the call to the computational subroutine with:

```
C Copy array pointers to local arrays.
    call mxCopyPtrToReal8(tr, tr, 1)
    call mxCopyPtrToReal8(yr, yr, 4)
C
C Call the computational subroutine.
    call yprime(ypr, tr, yr)
C
C Copy local array to output array pointer.
    call mxCopyReal8ToPtr(ypr, yp, 4)
```

You must also add the following declaration line to the top of the gateway routine:

```
real*8 ypr(4), tr, yr(4)
```

Note that if you use `mxCopyPtrToReal8` or any of the other `mxCopy*` routines, the size of the arrays declared in the Fortran gateway routine must be greater than or equal to the size of the inputs to the MEX-file coming in from MATLAB. Otherwise, `mxCopyPtrToReal8` does not work correctly.

Data Flow in MEX-Files

The following examples illustrate data flow in MEX-files:

- “Showing Data Input and Output” on page 5-7
- “Gateway Routine Data Flow Diagram” on page 5-8
- “MATLAB Example timestwo.F” on page 5-9

Showing Data Input and Output

Suppose your MEX-file `myFunction` has two input arguments and one output argument. The MATLAB syntax is `[X] = myFunction(Y, Z)`. To call `myFunction` from MATLAB, type:

```
X = myFunction(Y, Z);
```

The MATLAB interpreter calls `mexFunction`, the gateway routine to `myFunction`, with the following arguments:

```
nlhs = 1
```

```
nrhs = 2
```

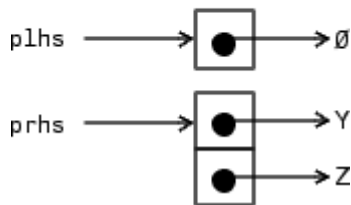

Your input is `prhs`, a two-element array (`nrhs = 2`). The first element is a pointer to an mxArray named `Y` and the second element is a pointer to an mxArray named `Z`.

Your output is `plhs`, a one-element array (`nlhs = 1`) where the single element is a null pointer. The parameter `plhs` points at nothing because the output `X` is not created until the subroutine executes.

The gateway routine creates the output array and sets a pointer to it in `plhs[0]`. If the routine does not assign a value to `plhs[0]` but you assign an output value to the function when you call it, MATLAB generates an error.

Note It is possible to return an output value even if `nlhs = 0`. This corresponds to returning the result in the *ans* variable.

Gateway Routine Data Flow Diagram

The following MEX Cycle diagram shows how inputs enter a MEX-file, what functions the gateway routine performs, and how outputs return to MATLAB.

In this example, the syntax of the MEX-file `func` is `[C, D] = func(A,B)`. In the figure, a call to `func` tells MATLAB to pass variables `A` and `B` to your MEX-file. `C` and `D` are left unassigned.

The gateway routine `func.F` uses the `mxCreate*` functions to create the MATLAB arrays for your output arguments. It sets `plhs[0]` and `plhs[1]` to the pointers to the newly created MATLAB arrays. It uses the `mxGet*` functions to extract your data from your input arguments `prhs[0]` and `prhs[1]`. Finally, it calls your computational routine, passing the input and output data pointers as function parameters.

MATLAB assigns `plhs[0]` to `C` and `plhs[1]` to `D`.

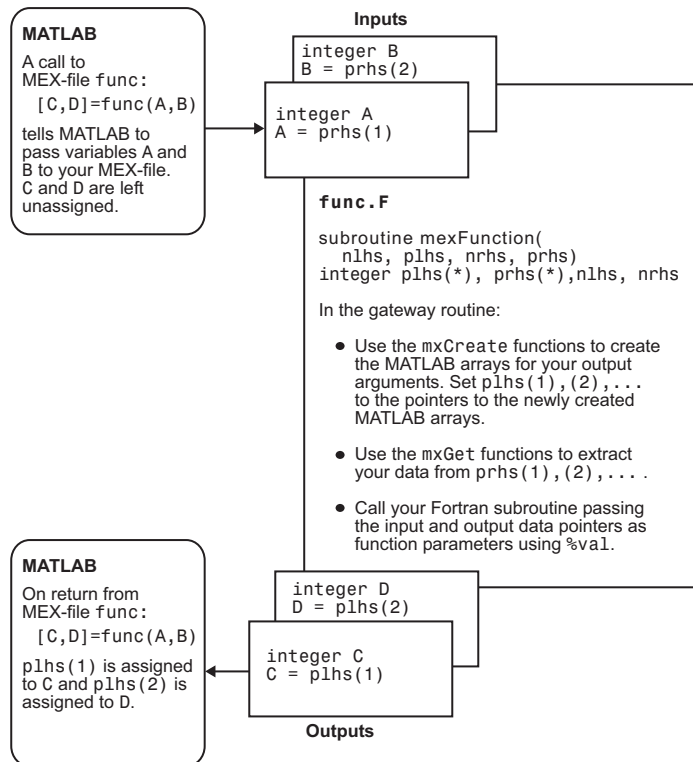

Fortran MEX Cycle

MATLAB Example `timestwo.F`

Let's look at an example, `timestwo.F`, found in your `matlabroot/extern/examples/refbook` folder. ("Build MEX-Files" on page 3-27 explains how to create the binary MEX-file.) Its calling syntax is `Y = timestwo(X)`, where `X` is a number. Type:

```
x = 99;
y = timestwo(x)
```

MATLAB displays:

```
y =
    198
```

The gateway routine validates the input arguments. This step includes checking the number, type, and size of the input arrays as well as examining the number of output arrays. If the inputs are not valid, call `mexErrMsgIdAndTxt`. For example:

```
C Check for proper number of arguments.
  if(nrhs .ne. 1) then
    call mexErrMsgIdAndTxt ('timestwo.F', 'One input required.')
  elseif(nlhs .gt. 1) then
    call mexErrMsgIdAndTxt ('timestwo.F', 'Too many output arguments.')
  endif

C Check that the input is a number.
  if(mxIsNumeric(prhs(1)) .eq. 0) then
    call mexErrMsgIdAndTxt ('timestwo.F', 'Input must be a number.')
  endif
```

To create MATLAB arrays, call one of the `mxCreate*` functions, like `mxCreateDoubleMatrix`, `mxCreateSparse`, or `mxCreateString`. If it needs them, the gateway routine can call `mxMalloc` to allocate temporary work arrays for the computational routine. In this example:

```
C Create matrix for the return argument.
  plhs(1) = mxCreateDoubleMatrix(mrows,ncols,0)
```

In the gateway routine, you access the data in `mxArray` and manipulate it in your computational subroutine. For example, the expression `mxGetPr(prhs[0])` returns a pointer of type `double *` to the real data in the `mxArray` pointed to by `prhs[0]`. You can then use this pointer like any other pointer of type `double *` in Fortran. For example:

```
C Create Fortran array from the input argument.
  inputptr = mxGetPr(prhs(1))
  call mxCopyPtrToReal8(inputptr, finput, nelements)
```

In this example, a computational routine, `timestwo`, performs the calculations:

```
C Call the computational subroutine.
  call timestwo(foutput, finput)
```

After calling your computational routine from the gateway, you can set a pointer of type `mxArray` to the data it returns. MATLAB recognizes the output from your computational routine as the output from the binary MEX-file.

```
C Load the data into outputptr, which is the output to MATLAB.  
    call mxCopyReal8ToPtr(foutput,outputptr,nelements)
```

When a binary MEX-file completes its task, it returns control to MATLAB. MATLAB automatically destroys any arrays created by the MEX-file not returned through the left-hand side arguments.

MathWorks recommends that MEX-file functions destroy their own temporary arrays and free their own dynamically allocated memory. It is more efficient to perform this cleanup in the source MEX-file than to rely on the automatic mechanism.

Set Up Fortran Examples

The “Fortran Matrix Library” provides a set of Fortran routines that handle the types supported by MATLAB. For each data type, there is a specific set of functions that you can use for data manipulation.

Source code for Fortran examples are located in the *matlabroot/extern/examples/refbook* folder of your MATLAB installation. To build these examples, make sure you have a Fortran compiler selected using the `mex -setup` command. Then at the MATLAB command prompt, type:

```
mex filename.F
```

where *filename* is the name of the example.

This section looks at source code for the examples. Unless otherwise specified, the term “MEX-file” refers to a source file.

For a list of MEX example files available with MATLAB, see “Table of MEX-File Source Code Files” on page 3-38.

Pass Scalar Values

Let's look at a simple example of Fortran code and its MEX-file equivalent. Here is a Fortran computational routine that takes a scalar and doubles it:

```
subroutine timestwo(y, x)
  real*8 x, y
C
  y = 2.0 * x
  return
end
```

To see the same function written in the MEX-file format (`timestwo.F`), open the file in MATLAB Editor.

To build this example, at the command prompt type:

```
mex timestwo.F
```

This command creates the binary MEX-file called `timestwo` with an extension corresponding to the machine type on which you're running. You can now call `timestwo` like a MATLAB function:

```
x = 2;
y = timestwo(x)
```

MATLAB displays:

```
y =
    4
```

Pass Strings

Passing strings from MATLAB to a Fortran MEX-file is straightforward. The program `revord.F` accepts a string and returns the characters in reverse order. To see the example `revord.F`, open the file in MATLAB Editor.

After checking for the correct number of inputs, the gateway routine `mexFunction` verifies that the input was a row vector string. It then finds the size of the string and places the string into a Fortran character array. Note that in the case of character strings, it is not necessary to copy the data into a Fortran character array using `mxCopyPtrToCharacter`. (`mxCopyPtrToCharacter` is a convenience function for working with MAT-files.)

To build this example, at the command prompt type:

```
mex revord.F
```

Type:

```
x = 'hello world';  
y = revord(x)
```

MATLAB displays:

```
y =  
  
dlrow olleh
```

Pass Arrays of Strings

Passing arrays of strings adds a complication to the example “Pass Strings” on page 5-14. Because MATLAB stores elements of a matrix by column instead of by row, the size of the string array must be correctly defined in the Fortran MEX-file. The key point is that the row and column sizes as defined in MATLAB must be reversed in the Fortran MEX-file. Consequently, when returning to MATLAB, the output matrix must be transposed.

This example places a string array/character matrix into MATLAB as output arguments rather than placing it directly into the workspace.

To build this example, at the command prompt type:

```
mex passstr.F
```

Type:

```
passstr;
```

to create the 5-by-15 `mystring` matrix. You need to do some further manipulation. The original string matrix is 5-by-15. Because of the way MATLAB reads and orients elements in matrices, the size of the matrix must be defined as `M=15` and `N=5` in the MEX-file. After the matrix is put into MATLAB, the matrix must be transposed. The program `passstr.F` illustrates how to pass a character matrix. To see the code `passstr.F`, open the file in MATLAB Editor.

Type:

```
passstr
```

MATLAB displays:

```
ans =
```

```
MATLAB  
The Scientific  
Computing  
Environment  
by TMW, Inc.
```

Pass Matrices

In MATLAB, you can pass matrices into and out of MEX-files written in Fortran. You can manipulate the MATLAB arrays by using `mxGetPr` and `mxGetPi` to assign pointers to the real and imaginary parts of the data stored in the MATLAB arrays. You can create new MATLAB arrays from within your MEX-file by using `mxCreateDoubleMatrix`.

The example `matsq.F` takes a real 2-by-3 matrix and squares each element. To see the source code, open the file in MATLAB Editor.

After performing error checking to ensure that the correct number of inputs and outputs was assigned to the gateway subroutine and to verify the input was in fact a numeric matrix, `matsq.F` creates a matrix. The matrix is copied to a Fortran matrix using `mxCopyPtrToReal8`. Now the computational subroutine can be called, and the return argument is placed into `y_ptr`, the pointer to the output, using `mxCopyReal8ToPtr`.

To build this example, at the command prompt type:

```
mex matsq.F
```

For a 2-by-3 real matrix, type:

```
x = [1 2 3; 4 5 6];  
y = matsq(x)
```

MATLAB displays:

```
y =  
    1     4     9  
   16    25    36
```

Pass Integers

The example `matsqint8.F` accepts a matrix of MATLAB type `int8` and squares each element. To see the source code, open the file in MATLAB Editor. Data of type `int8`, a signed 8-bit integer, is equivalent to Fortran type `integer*1`, a signed 1-byte integer. Use the API functions `mxCopyPtrToInteger1` and `mxCopyInteger1ToPtr` to copy values between MATLAB and Fortran arrays.

To build this example, at the command prompt type:

```
mex matsqint8.F
```

Type:

```
B = int8([1 2; 3 4; -5 -6]);  
y = matsqint8(B)
```

MATLAB displays:

```
y =  
    1    4  
    9   16  
   25   36
```

For information about using other integer data types, consult your Fortran compiler manual.

Pass Multiple Inputs or Outputs

The `p1hs` and `prhs` parameters (see “The Components of a Fortran MEX-File” on page 5-2) are vectors containing pointers to the left-hand side (output) variables and right-hand side (input) variables. `p1hs(1)` contains a pointer to the first left-hand side argument, `p1hs(2)` contains a pointer to the second left-hand side argument, and so on. Likewise, `prhs(1)` contains a pointer to the first right-hand side argument, `prhs(2)` points to the second, and so on.

The example `xtimesy.F` multiplies an input scalar times an input scalar or matrix. To see the source code, open the file in MATLAB Editor.

As this example shows, creating MEX-file gateways that handle multiple inputs and outputs is straightforward. All you need to do is keep track of which indices of the vectors `prhs` and `p1hs` correspond to which input and output arguments of your function. In this example, the input variable `x` corresponds to `prhs(1)` and the input variable `y` to `prhs(2)`.

To build this example, at the command prompt type:

```
mex xtimesy.F
```

For an input scalar `x` and a real 3-by-3 matrix, type:

```
x = 3; y = ones(3);  
z = xtimesy(x, y)
```

MATLAB displays:

```
z =  
    3    3    3  
    3    3    3  
    3    3    3
```

Handle Complex Data

MATLAB stores complex double-precision data as two vectors of numbers—one vector contains the real data and the other contains the imaginary data. The functions `mxCopyPtrToComplex16` and `mxCopyComplex16ToPtr` copy MATLAB data to a native `complex*16` Fortran array.

The example `convec.F` takes two complex vectors (of length 3) and convolves them. To see the source code, open the file in MATLAB Editor.

To build this example, at the command prompt type:

```
mex convec.F
```

Enter the following at the command prompt:

```
x = [3 - 1i, 4 + 2i, 7 - 3i];  
y = [8 - 6i, 12 + 16i, 40 - 42i];
```

Type:

```
z = convec(x, y)
```

MATLAB displays:

```
z =  
  
1.0e+02 *  
  
Columns 1 through 4  
  
0.1800 - 0.2600i    0.9600 + 0.2800i    1.3200 - 1.4400i  
3.7600 - 0.1200i  
  
Column 5  
  
1.5400 - 4.1400i
```

which agrees with the results the built-in MATLAB function `conv.m` produces.

Dynamically Allocate Memory

To allocate memory dynamically in a Fortran MEX-file, use `%val`. (See “Using the Fortran `%val` Construct” on page 5-6.) The example `dblmat.F` takes an input matrix of real data and doubles each of its elements. To see the source code, open the file in MATLAB Editor. `compute.F` is the subroutine `dblmat` calls to double the input matrix. (Open the file in MATLAB Editor.)

To build this example, at the command prompt type:

```
mex dblmat.F compute.F
```

For the 2-by-3 matrix, type:

```
x = [1 2 3; 4 5 6];  
y = dblmat(x)
```

MATLAB displays:

```
y =  
    2     4     6  
    8    10    12
```

Note The `dblmat.F` example, as well as `fulltosparse.F` and `sincall.F`, are split into two parts, the gateway and the computational subroutine, because of restrictions in some compilers.

Handle Sparse Matrices

MATLAB provides a set of functions that allow you to create and manipulate sparse matrices. There are special parameters associated with sparse matrices, namely `ir`, `jc`, and `nzmax`. For information on how to use these parameters and how MATLAB stores sparse matrices in general, see “Sparse Matrices” on page 3-23.

Note Sparse array indexing is zero-based, not one-based.

The `fulltosparse.F` example illustrates how to populate a sparse matrix. To see the source code, open the file in MATLAB Editor. `loadsparse.F` is the subroutine `fulltosparse` calls to fill the `mxArray` with the sparse data. (Open the file in MATLAB Editor.)

To build this example, at the command prompt type:

```
mex fulltosparse.F loadsparse.F
```

At the command prompt, typing:

```
full = eye(5)
full =
     1     0     0     0     0
     0     1     0     0     0
     0     0     1     0     0
     0     0     0     1     0
     0     0     0     0     1
```

creates a full, 5-by-5 identity matrix. Using `fulltosparse` on the full matrix produces the corresponding sparse matrix:

```
spar = fulltosparse(full)
spar =
(1,1)     1
(2,2)     1
(3,3)     1
(4,4)     1
(5,5)     1
```

Call MATLAB Functions from Fortran MEX-Files

You can call MATLAB functions, operators, user-defined functions, and other binary MEX-files from within your Fortran source code by using the API function `mexCallMATLAB`. The `sincall.F` example creates an `mxArray`, passes various pointers to a local function to acquire data, and calls `mexCallMATLAB` to calculate the sine function and plot the results. To see the source code, open the file in MATLAB Editor. `fill.F` is the subroutine `sincall` calls to fill the `mxArray` with data. (Open the file in MATLAB Editor.)

It is possible to use `mexCallMATLAB` (or any other API routine) from within your computational Fortran subroutine. Note that you can only call most MATLAB functions with double-precision data. Some functions that perform computations, such as `eig`, do not work correctly with data that is not double precision.

To build this example, at the command prompt type:

```
mex sincall.F fill.F
```

Running this example:

```
sincall
```

displays the results:

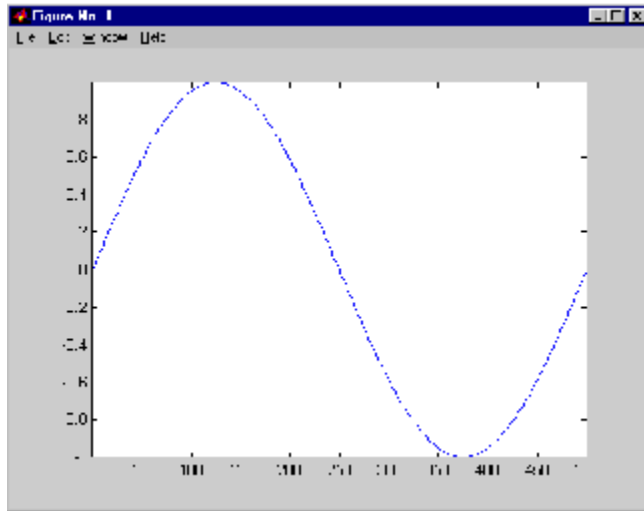

Note You can generate an object of type `mxUNKNOWN_CLASS` using `mexCallMATLAB`. See the following example.

This function returns two variables but only assigns one of them a value:

```
function [a,b]=foo[c]
a=2*c;
```

If you then call `foo` using `mexCallMATLAB`, the unassigned output variable is now of type `mxUNKNOWN_CLASS`.

Debug Fortran Source MEX-Files

In this section...
“Notes on Debugging” on page 5-24
“Debugging on Microsoft Windows Platforms” on page 5-24
“Debugging on Linux Platforms” on page 5-24

Notes on Debugging

The examples show how to debug `timestwo.F`, found in your `matlabroot/extern/examples/refbook` folder.

Binary MEX-files built with the `-g` option do not execute on other computers because they rely on files that are not distributed with MATLAB software. For additional information on isolating problems with MEX-files, see “Troubleshoot MEX-Files”.

Debugging on Microsoft Windows Platforms

For MEX-files compiled with any version of the Intel Visual Fortran compiler, you can use the debugging tools found in your version of Microsoft Visual Studio. Refer to the “Creating C/C++ Language MEX-Files” topic “Debugging on the Microsoft Windows Platforms” on page 4-32 for instructions on using this debugger.

Debugging on Linux Platforms

The MATLAB supported Fortran compiler `g95` has a `-g` option for building binary MEX-files with debug information. Such files can be used with `gdb`, the GNU Debugger. This section describes using `gdb`.

GNU Debugger `gdb`

In this example, the MATLAB command prompt `>>` is shown in front of MATLAB commands, and `linux>` represents a Linux prompt; your system may show a different prompt. The debugger prompt is `<gdb>`.

1 To compile the source MEX-file, type:

```
linux> mex -g timestwo.F
```

- 2 At the Linux prompt, start the gdb debugger using the `matlab -D` option:

```
linux> matlab -Dgdb
```

- 3 Start MATLAB without the Java Virtual Machine (JVM) by using the `-nojvm` startup flag:

```
<gdb> run -nojvm
```

- 4 In MATLAB, enable debugging with the `dbmex` function and run your binary MEX-file:

```
>> dbmex on  
>> y = timestwo(4)
```

- 5 At this point, you are ready to start debugging.

It is often convenient to set a breakpoint at `mexFunction` so you stop at the beginning of the gateway routine.

Note The function name may be slightly altered by the compiler (for example, it may have an underscore appended). To determine how this symbol appears in a given MEX-file, use the Linux command `nm`. For example:

```
linux> nm timestwo.mexa64 | grep -i mexfunction
```

The operating system responds with something like:

```
0000091c T mexfunction_
```

Use `mexFunction` in the breakpoint statement. Be sure to use the correct case.

```
<gdb> break mexfunction_  
<gdb> continue
```

- 6** Once you hit one of your breakpoints, you can make full use of any commands the debugger provides to examine variables, display memory, or inspect registers.

To proceed from a breakpoint, type `continue`:

```
<gdb> continue
```

- 7** After stopping at the last breakpoint, type:

```
<gdb> continue
```

`timestwo` finishes and MATLAB displays:

```
y =
```

```
      8
```

- 8** From the MATLAB prompt you can return control to the debugger by typing:

```
>> dbmex stop
```

Or, if you are finished running MATLAB, type:

```
>> quit
```

- 9** When you are finished with the debugger, type:

```
<gdb> quit
```

You return to the Linux prompt.

Refer to the documentation provided with your debugger for more information on its use.

Handling Large mxArray

Binary MEX-files built on 64-bit platforms can handle 64-bit mxArray. These large data arrays can have up to $2^{48}-1$ elements. The maximum number of elements a sparse mxArray can have is $2^{48}-2$.

Using the following instructions creates platform-independent binary MEX-files as well.

Your system configuration can impact the performance of MATLAB. The 64-bit processor requirement enables you to create the mxArray and access data in it. However, your system's memory, in particular the size of RAM and virtual memory, determine the speed at which MATLAB processes the mxArray. The more memory available, the faster the processing.

The amount of RAM also limits the amount of data you can process at one time in MATLAB. For guidance on memory issues, see "Strategies for Efficient Use of Memory". Memory management within source MEX-files can have special considerations, as described in "Memory Management" on page 4-47.

Using the 64-Bit API

The signatures of the API functions shown in the following table use the `mwSize` or `mwIndex` types to work with a 64-bit mxArray. The variables you use in your source code to call these functions must be the correct type.

mxArray Functions Using `mwSize`/`mwIndex`

<code>mxCalcSingleSubscript</code>	<code>mxCreateSparseLogicalMatrix</code> ²
<code>mxCalloc</code>	<code>mxCreateStructArray</code>
<code>mxCopyCharacterToPtr</code> ¹	<code>mxCreateStructMatrix</code>
<code>mxCopyComplex16ToPtr</code> ¹	<code>mxGetCell</code>
<code>mxCopyComplex8ToPtr</code> ¹	<code>mxGetDimensions</code>
<code>mxCopyInteger1ToPtr</code> ¹	<code>mxGetElementSize</code>
<code>mxCopyInteger2ToPtr</code> ¹	<code>mxGetField</code>
<code>mxCopyInteger4ToPtr</code> ¹	<code>mxGetFieldByNumber</code>

mxArray Functions Using mwSize/mwIndex (Continued)

<code>mxCopyPtrToCharacter</code> ¹	<code>mxGetIr</code>
<code>mxCopyPtrToComplex16</code> ¹	<code>mxGetJc</code>
<code>mxCopyPtrToComplex8</code> ¹	<code>mxGetM</code>
<code>mxCopyPtrToInteger1</code> ¹	<code>mxGetN</code>
<code>mxCopyPtrToInteger2</code> ¹	<code>mxGetNumberOfDimensions</code>
<code>mxCopyPtrToInteger4</code> ¹	<code>mxGetNumberOfElements</code>
<code>mxCopyPtrToPtrArray</code> ¹	<code>mxGetNzmax</code>
<code>mxCopyPtrToReal4</code> ¹	<code>mxGetProperty</code>
<code>mxCopyPtrToReal8</code> ¹	<code>mxGetString</code>
<code>mxCopyReal4ToPtr</code> ¹	<code>mxMalloc</code>
<code>mxCopyReal8ToPtr</code> ¹	<code>mxRealloc</code>
<code>mxCreateCellArray</code>	<code>mxSetCell</code>
<code>mxCreateCellMatrix</code>	<code>mxSetDimensions</code>
<code>mxCreateCharArray</code>	<code>mxSetField</code>
<code>mxCreateCharMatrixFromStrings</code>	<code>mxSetFieldByNumber</code>
<code>mxCreateDoubleMatrix</code>	<code>mxSetIr</code>
<code>mxCreateLogicalArray</code> ²	<code>mxSetJc</code>
<code>mxCreateLogicalMatrix</code> ²	<code>mxSetM</code>
<code>mxCreateNumericArray</code>	<code>mxSetN</code>
<code>mxCreateNumericMatrix</code>	<code>mxSetNzmax</code>
<code>mxCreateSparse</code>	<code>mxSetProperty</code>

¹Fortran function only

²C function only

Functions in this API use the `mwIndex`, `mwSize`, and `mwPointer` preprocessor macros. For information about using these macros, see “Required Header Files” on page 5-4.

Building the Binary MEX-File

Use the mex build script option `-largeArrayDims` with the 64-bit API.

Caution Using Negative Values

When using the 64-bit API, `mwSize` and `mwIndex` are equivalent to `INTEGER*8` in Fortran. This type is unsigned, unlike `INTEGER*4`, which is the type used in the 32-bit API. Be careful not to pass any negative values to functions that take `mwSize` or `mwIndex` arguments. Do not cast negative `INTEGER*4` values to `mwSize` or `mwIndex`; the returned value cannot be predicted. Instead, change your code to avoid using negative values.

Building Cross-Platform Applications

If you develop cross-platform applications (programs that can run on both 32- and 64-bit architectures), you must pay attention to the upper limit of values you use for `mwSize` and `mwIndex`. The 32-bit application reads these values and assigns them to variables declared as `INTEGER*4` in Fortran. Be careful to avoid assigning a large `mwSize` or `mwIndex` value to an `INTEGER*4` or other variable that might be too small.

Memory Management

When a binary MEX-file returns control to MATLAB, it returns the results of its computations in the output arguments—the `mxArrays` contained in the left-hand side arguments `pLhs[]`. MATLAB destroys any `mxArray` created by the MEX-file that is not in this argument list. In addition, MATLAB frees any memory that was allocated in the MEX-file using the `mxMalloc`, `mxRealloc`, or `mxMalloc` functions.

Consequently, any misconstructed arrays left over at the end of a binary MEX-file's execution have the potential to cause memory errors.

MathWorks recommends that MEX-file functions destroy their own temporary arrays and free their own dynamically allocated memory. It is more efficient to perform this cleanup in the source MEX-file than to rely on the automatic mechanism. For additional information on memory management techniques, see the sections “Memory Management” on page 4-47 in *Creating C/C++ Language MEX-Files* and “Memory Management Issues” on page 3-97.

Calling MATLAB Engine from C/C++ and Fortran Programs

- “Using MATLAB Engine” on page 6-2
- “Call MATLAB Functions from C Applications” on page 6-6
- “Call MATLAB Functions from C++ Applications” on page 6-8
- “Call MATLAB Functions from Fortran Applications” on page 6-9
- “Attach to Existing MATLAB Sessions” on page 6-11
- “Compiling Engine Applications with MEX Command” on page 6-13
- “Compiling Engine Applications with IDE” on page 6-19
- “Troubleshooting Engine Applications” on page 6-23

Using MATLAB Engine

In this section...
“Introduction to MATLAB Engine” on page 6-2
“What You Need to Build Engine Applications” on page 6-3
“The Engine Library” on page 6-4
“GUI-Intensive Applications” on page 6-5

Introduction to MATLAB Engine

The MATLAB engine library contains routines that allow you to call MATLAB software from your own programs, thereby employing MATLAB as a computation engine. You must use an installed version of MATLAB; you cannot run the MATLAB engine on a machine that only has the MATLAB Compiler Runtime (MCR).

Engine programs are standalone C/C++ or Fortran programs that communicate with a separate MATLAB process via pipes, on UNIX systems, and through a Microsoft Component Object Model (COM) interface, on Microsoft Windows systems. MATLAB provides a library of functions that allows you to start and end the MATLAB process, send data to and from MATLAB, and send commands to be processed in MATLAB.

Some of the things you can do with the MATLAB engine are:

- Call a math routine, for example, to invert an array or to compute an FFT from your own program. When employed in this manner, MATLAB is a powerful and programmable mathematical subroutine library.
- Build an entire system for a specific task, for example, radar signature analysis or gas chromatography, where the front end (GUI) is programmed in C/C++ and the back end (analysis) is programmed in MATLAB, which can shorten development time.

The MATLAB engine operates by running in the background as a separate process from your own program. This offers several advantages:

- On UNIX systems, the engine can run on your machine, or on any other UNIX machine on your network, including machines of a different architecture. This allows you to implement a user interface on your workstation and perform the computations on a faster machine located elsewhere on your network. For more information, see the `engOpen` reference page.
- Instead of requiring your program to link to the entire MATLAB program (a substantial amount of code), it links to a smaller engine library.

The MATLAB engine cannot read MAT-files in a format based on HDF5. These are MAT-files saved using the `-v7.3` option of the `save` function or opened using the `w7.3` mode argument to the C or Fortran `matOpen` function.

Note To run MATLAB engine on the UNIX platform, you must have the C shell `cs` installed at `/bin/csh`.

What You Need to Build Engine Applications

To create an engine application, you need the tools and knowledge to modify and build source code in C/C++ or Fortran. In particular, you need a compiler supported by MATLAB. For an up-to-date list of supported compilers, see the Supported and Compatible Compilers Web page.

In your application, use functions in the MATLAB C/C++ and Fortran API:

- “The Engine Library” on page 6-4
- MX Matrix Library

To build the application, use the `mex` build script with the compiler-specific engine options file. For more information, see “Compiling Engine Applications with MEX Command” on page 6-13. You can also use your own build tools, as described in “Compiling Engine Applications with IDE” on page 6-19.

The Engine Library

The engine library is part of the MATLAB C/C++ and Fortran API. It contains routines for controlling the computation engine. The function names begin with the three-letter prefix `eng`.

MATLAB libraries are not thread-safe. If you create multithreaded applications, make sure only one thread accesses the engine application.

C Engine Routines

Function	Purpose
<code>engOpen</code>	Start up MATLAB engine
<code>engClose</code>	Shut down MATLAB engine
<code>engGetVariable</code>	Get a MATLAB array from the engine
<code>engPutVariable</code>	Send a MATLAB array to the engine
<code>engEvalString</code>	Execute a MATLAB command
<code>engOutputBuffer</code>	Create a buffer to store MATLAB text output
<code>engOpenSingleUse</code>	Start a MATLAB engine session for single, nonshared use
<code>engGetVisible</code>	Determine visibility of MATLAB engine session
<code>engSetVisible</code>	Show or hide MATLAB engine session

Fortran Engine Routines

Function	Purpose
<code>engOpen</code>	Start up MATLAB engine
<code>engClose</code>	Shut down MATLAB engine
<code>engGetVariable</code>	Get a MATLAB array from the engine
<code>engPutVariable</code>	Send a MATLAB array to the engine
<code>engEvalString</code>	Execute a MATLAB command
<code>engOutputBuffer</code>	Create a buffer to store MATLAB text output

Engine programs also use the MX Matrix Library in the C/C++ and Fortran API. For more information about this library, see “Introducing MEX-Files” on page 3-2.

Communicating with MATLAB Software

On UNIX systems, the engine library communicates with the engine using pipes, and, if needed, `rsh` for remote execution. On Microsoft Windows systems, the engine library communicates with the engine using a Component Object Model (COM) interface. For more information, see “MATLAB COM Integration” on page 9-2.

GUI-Intensive Applications

If you have graphical user interface (GUI) intensive applications that execute a lot of callbacks through the MATLAB engine, you should force these callbacks to be evaluated in the context of the base workspace. Use `evalin` to specify that the base workspace be used in evaluating the callback expression, as follows:

```
engEvalString(ep, "evalin('base', expression)")
```

Specifying the base workspace in this manner ensures MATLAB processes the callback correctly and returns results for that call.

This does not apply to computational applications that do not execute callbacks.

Call MATLAB Functions from C Applications

The program `engdemo.c`, in the `matlabroot/extern/examples/eng_mat` folder, illustrates how to call the engine functions from a standalone C program. For the Microsoft Windows version of this program, see `engwindemo.c`.

To see `engdemo.c`, open this file in MATLAB Editor.

To see the Windows version `engwindemo.c`, open this file.

The first part of this program launches MATLAB and sends it data. MATLAB analyzes the data and plots the results.

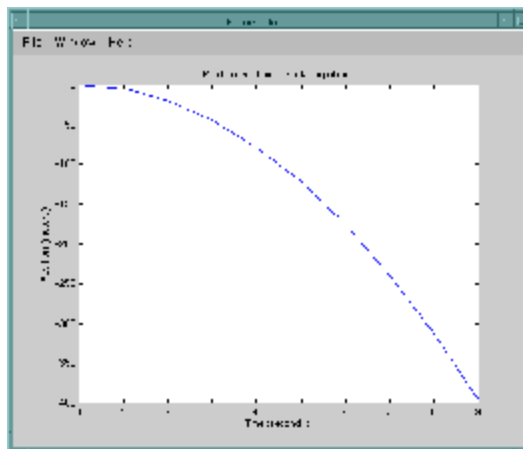

The program continues with:

Press Return to continue

Pressing **Return** continues the program:

Done for Part I.

Enter a MATLAB command to evaluate. This command should create a variable X. This program will then determine what kind of variable you created.

For example: `X = 1:5`

Entering `X = 17.5` continues the program execution.

```
X = 17.5
```

```
X =
```

```
    17.5000
```

```
Retrieving X...
```

```
X is class double
```

```
Done!
```

Finally, the program frees memory, closes the MATLAB engine, and exits.

Call MATLAB Functions from C++ Applications

There is a C++ version of `engdemo` in the `matlabroot\extern\examples\eng_mat` folder. To see `engdemo.cpp`, open this file.

Call MATLAB Functions from Fortran Applications

The program `fengdemo.F`, in the `matlabroot/extern/examples/eng_mat` folder, illustrates how to call the engine functions from a standalone Fortran program. To see the code, open this file.

Executing this program launches MATLAB, sends it data, and plots the results.

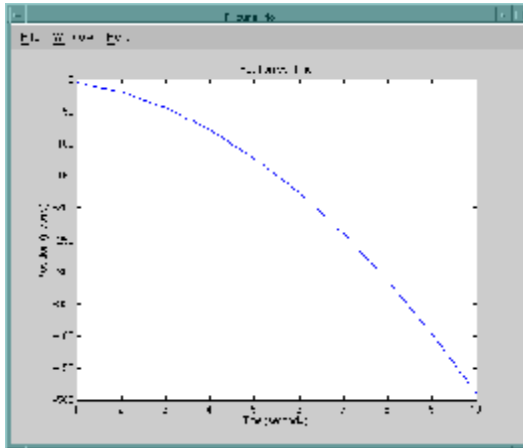

The program continues with:

```
Type 0 <return> to Exit
Type 1 <return> to continue
```

Entering 1 at the prompt continues the program execution:

```
1
MATLAB computed the following distances:
  time(s)  distance(m)
  1.00     -4.90
  2.00     -19.6
  3.00     -44.1
  4.00     -78.4
  5.00     -123.
  6.00     -176.
```

7.00	-240.
8.00	-314.
9.00	-397.
10.0	-490.

Finally, the program frees memory, closes the MATLAB engine, and exits.

Attach to Existing MATLAB Sessions

On a Windows platform, you can attach an engine program to a MATLAB session that is already running by starting the MATLAB session with `/Automation` in the command line. When you call `engOpen`, it connects to this existing session. You should only call `engOpen` once, because any `engOpen` calls now connect to this one MATLAB session.

The `/Automation` option also causes the command window to be minimized. You must open it manually.

Note For more information on the `/Automation` command-line argument, see “Launch MATLAB as Automation Server in Desktop Mode” on page 11-17. For information about the Component Object Model interfaces used by MATLAB, see “MATLAB COM Integration” on page 9-2.

For example,

- 1 Shut down any MATLAB sessions.
- 2 From the **Start** button on the Windows menu bar, click **Run**.
- 3 In the **Open** field, type:

```
d:\matlab\bin\win32\matlab.exe /Automation
```

or:

```
d:\matlab\bin\win64\matlab.exe /Automation
```

where `d:\matlab\bin\win32` or `d:\matlab\bin\win64` represents the path to the MATLAB executable.

- 4 Click **OK**. This starts MATLAB.
- 5 In MATLAB, change directories to `matlabroot/extern/examples/eng_mat`.
- 6 Compile the `engwindemo.c` example.

7 Run the `engwindemo` program by typing at the MATLAB prompt:

```
!engwindemo
```

This does not start another MATLAB session, but rather uses the MATLAB session that is already open.

Note On the UNIX platform, you cannot make an engine program connect to an existing MATLAB session.

Compiling Engine Applications with MEX Command

In this section...

“Requirements to Build and Run Engine Applications” on page 6-13

“Building and Running Engine Applications on Windows Operating Systems” on page 6-14

“Windows Engine Example engwindemo” on page 6-16

“Building and Running Engine Applications on UNIX Operating Systems” on page 6-17

“UNIX Engine Example engdemo” on page 6-18

Requirements to Build and Run Engine Applications

To create an engine application, you need to build with an options file and set the run-time library path. The following topics describe these general requirements. For platform-specific information, see “Building and Running Engine Applications on Windows Operating Systems” on page 6-14 or “Building and Running Engine Applications on UNIX Operating Systems” on page 6-17.

Building With the Engine Options File

Use the `mex` function to compile and link engine applications. MATLAB provides an *options file* containing compiler-specific flags that correspond to the general compile, prelink, and link steps required by your development tools. The name of the options file depends on your operating system and which compiler you use. For Windows systems, see “Engine Options Files on Windows” on page 6-14. On UNIX systems, the options file is `engopts.sh` in the `matlabroot/bin` folder.

The format of the build command is:

```
mex('-f',fullfile(optionsPath,optionsName),fileName);
```

where *fileName* is the name of your C/C++ or Fortran source file, and *optionsPath* and *optionsName* make up the full file name of the options file.

Alternatively, copy the options file to your current working folder, and then enter a command like:

```
mex -f optionsName fileName
```

Run-Time Requirements

At run time, tell the operating system where the MATLAB API shared libraries reside by setting the run-time library Path environment variable. For instructions, see “Setting Run-Time Library Path on Windows” on page 6-15 or “Setting Run-Time Library Path on Linux and Macintosh” on page 6-17.

If you have multiple versions of MATLAB installed on your system, the version you use to build your engine applications must be the first listed in your system Path environment variable. Otherwise, MATLAB displays Can't start MATLAB engine. For information about setting the Path variable, see “Setting Run-Time Library Path on Windows” on page 6-15 or “Setting Run-Time Library Path on Linux and Macintosh” on page 6-17.

Building and Running Engine Applications on Windows Operating Systems

The following topics describe what you need to know to create engine applications. For an example, see “Windows Engine Example engwindemo” on page 6-16.

- “Engine Options Files on Windows” on page 6-14
- “Setting Run-Time Library Path on Windows” on page 6-15
- “Registering MATLAB Software as a COM Server” on page 6-15

Engine Options Files on Windows

The name of the options file is *engmatopts.bat, where * is a string representing the compiler name and version. To identify the options files on your system, type:

```
dir(fullfile(matlabroot,...  
    'bin',computer('arch'),'mexopts','*engmatopts.bat'))
```

The `Name` and `Version` properties of a `mex.CompilerConfiguration` object can help you select an options file. Type:

```
cc = mex.getCompilerConfigurations('any','supported');
```

For example, for a `cc` object with the following properties, chose the `msvc90engmatopts.bat` options file.

Properties:

```
Name: 'Microsoft Visual C++ 2008'
Manufacturer: 'Microsoft'
Language: 'C++'
Version: '9.0'
Location: 'c:\Program Files (x86)\Microsoft Visual Studio 9.0'
Details: [1x1 mex.CompilerConfigurationDetails]
```

Setting Run-Time Library Path on Windows

Set the `Path` environment variable to the path string returned by the following MATLAB command:

```
fullfile(matlabroot,'bin',computer('arch'))
```

To set an environment variable on Windows XP, select **Start > Settings > Control Panel > System**. The System Properties dialog box appears. Click the **Advanced** tab, and then click the **Environment Variables** button.

In the **System variables** panel scroll down until you find the `Path` variable. Click this variable to highlight it, and then click the **Edit** button to open the Edit System Variable dialog box. At the end of the path string, enter a semicolon. Then, enter the path string that MATLAB returns after evaluating the expression shown above. Click **OK** in the Edit System Variable dialog box, and in all remaining dialog boxes.

Registering MATLAB Software as a COM Server

To run the engine application on a Windows operating system, you need to register MATLAB as a COM server. Do this for every session, to ensure that the current version of MATLAB is the registered version. If you run

older versions, the registered version could change. If there is a mismatch of version numbers, MATLAB displays Can't start MATLAB engine.

To manually register MATLAB as a server, type:

```
cd(fullfile(matlabroot, 'bin', computer('arch')))  
!matlab /regserver
```

Close the MATLAB window that appears.

Windows Engine Example engwindemo

To verify the build process on your computer, use the C example `engwindemo.c`.

- 1 Copy the file to your current working folder:

```
copyfile(fullfile(matlabroot,...  
    'extern','examples','eng_mat','engwindemo.c'),...  
    '.', 'f');
```

- 2 Build the executable file. If you are using a Microsoft Visual C++ compiler, select the appropriate options file, as described in “Engine Options Files on Windows” on page 6-14. If you selected the Lcc compiler, type:

```
mex('-v', '-f', fullfile(matlabroot,...  
    'bin','win32','mexopts','lccengmatopts.bat'),...  
    'engwindemo.c');
```

Note Use the Lcc or a Microsoft Visual C++ compiler to build `engwindemo.exe`. The source code in `engwindemo.c` is not supported for the Open Watcom compiler.

- 3 Verify that the build worked by looking in your current working folder for the `engwindemo.exe` file:

```
dir engwindemo.exe
```

- 4 Run the example from MATLAB:

```
!engwindemo
```

For more information about the `engwindemo` application, see “Call MATLAB Functions from C Applications” on page 6-6.

Building and Running Engine Applications on UNIX Operating Systems

The following topics describe what you need to know to create engine applications. For an example, see “UNIX Engine Example `engdemo`” on page 6-18.

- “Engine Options File on UNIX” on page 6-17
- “Setting Run-Time Library Path on Linux and Macintosh” on page 6-17

Engine Options File on UNIX

On UNIX systems, the options file is:

```
engopts.sh
```

and the path is:

```
fullfile(matlabroot, 'bin')
```

Setting Run-Time Library Path on Linux and Macintosh

The UNIX command you use and the value you provide to set the run-time library path depend on your shell and system architecture. The following table lists the name of the environment variable, *envvar*, and the values, *pathspec*, to assign to it.

Operating System	<i>envvar</i>	<i>pathspec</i>
64-bit Linux	LD_LIBRARY_PATH	<i>matlabroot/bin/glnxa64:</i> <i>matlabroot/sys/os/glnxa64</i>
64-bit Apple Macintosh (Intel)	DYLD_LIBRARY_PATH	<i>matlabroot/bin/maci64:</i> <i>matlabroot/sys/os/maci64</i>

C Shell. Set the library path using the command:

```
setenv envvar pathspec
```

Bourne Shell. Set the library path using the command:

```
envvar = pathspec:envvar export envvar
```

UNIX Engine Example engdemo

To verify the build process on your computer, use the C example `engdemo.c` or the C++ example `engdemo.cpp`.

- 1 Copy one of the programs, for example, `engdemo.c`, to your current working folder:

```
copyfile(fullfile(matlabroot,...  
    'extern','examples','eng_mat','engdemo.c'),...  
    '.', 'f');
```

- 2 Build the executable file:

```
mex('-v', '-f', fullfile(matlabroot,...  
    'bin','engopts.sh'),...  
    'engdemo.c');
```

- 3 Verify that the build worked by looking in your current working folder for the `engdemo` application:

```
dir engdemo
```

- 4 Run the example in MATLAB:

```
!engdemo
```

For more information about the `engdemo` applications, see “Call MATLAB Functions from C Applications” on page 6-6.

Compiling Engine Applications with IDE

In this section...

“Configuring the IDE” on page 6-19

“Files Required by Engine Applications” on page 6-19

Configuring the IDE

If your integrated development environment (IDE) has a MATLAB-supported compiler, you can use the IDE to build engine applications. For an up-to-date list of supported compilers, see the Supported and Compatible Compilers Web page.

Engine applications require the Engine Library `libeng`, the MX Matrix Library `libmx`, and supporting include files, described in “Files Required by Engine Applications” on page 6-19. When you build using the `mex` command, MATLAB is configured to locate these files. When you build in your IDE, you must configure the IDE to locate them. Where these settings are depends on your IDE. Refer to your product documentation.

This section provides information on how to build in an IDE, such as Microsoft Visual Studio. It is not inclusive and assumes that you know how to use the IDE. If you need more information, refer to your product documentation. It helps to be familiar with the information in “Compiling Engine Applications with MEX Command” on page 6-13. Use this information to build an example to make sure the process works. Then configure your IDE with the information from the engine options file.

MathWorks provides Technical Support solutions for configuring specific IDEs. For using Microsoft Visual Studio, see 1-78077S. For using Macintosh Xcode, see 1-4CKF73.

Files Required by Engine Applications

- “Specifying Engine Include Files” on page 6-20
- “Specifying Engine Libraries” on page 6-20

- “Specifying Library Files Required by libeng” on page 6-21
- “Specifying ICU Data Files” on page 6-21

Specifying Engine Include Files

Header files contain function declarations with prototypes for the routines you access in the API libraries. These files are the same for both Windows and UNIX systems. Engine applications use:

- `engine.h` — function prototypes for engine routines
- `matrix.h` — definition of the `mxArray` structure and function prototypes for matrix access routines

In your IDE, set the pre-processor include path to the value returned by the following MATLAB command:

```
fullfile(matlabroot, 'extern', 'include')
```

Specifying Engine Libraries

You need the `libeng` and `libmx` shared libraries. The name of the file is platform-specific, as shown in the following table.

Library File Names by Operating System

Windows	Linux	Macintosh (Intel)
<code>libeng.dll</code>	<code>libeng.so</code>	<code>libeng.dylib</code>
<code>libmx.dll</code>	<code>libmx.so</code>	<code>libmx.dylib</code>

Add these library names to your IDE configuration. Set the library path to the value returned by the following MATLAB command:

```
fullfile(matlabroot, 'bin', computer('arch'))
```

Refer to your IDE product documentation for instructions. For example, see Technical Support solution 1-78077S.

Specifying Library Files Required by libeng

The `libeng` library requires additional third-party library files. MATLAB uses these libraries to support Unicode character encoding and data compression in MAT-files.

These library files must reside in the same folder as the `libmx` library. You can determine what these libraries are using the platform-specific commands shown in the following table. Once you identify these files, update your IDE, following the instructions in “Specifying Engine Libraries” on page 6-20.

Library Dependency Commands

Windows	Linux	Macintosh
See the following instructions for Dependency Walker	<code>ldd -d libeng.so</code>	<code>otool -L libeng.dylib</code>

On Windows systems, to find library dependencies, use the third-party product Dependency Walker. Dependency Walker is a free utility that scans any 32-bit or 64-bit Windows module and builds a hierarchical tree diagram of all dependent modules. For each module found, it lists all the functions that are exported by that module, and which of those functions are called by other modules. Download the Dependency Walker utility from the following Web site:

<http://www.dependencywalker.com/>

See the Technical Support solution 1-2RQL4L at <http://www.mathworks.com/support/solutions/data/1-2RQL4L.html> for information on using the Dependency Walker.

Drag and drop the `libeng.dll` file into the Depends window. Identify the dependent libraries and add them to your IDE configuration, following the instructions in “Specifying Engine Libraries” on page 6-20.

Specifying ICU Data Files

Verify that the appropriate ICU data file is installed. The ICU file name is:

`icudtver.dat`

where *ver* is a version-specific integer. The ICU file path is:

```
fullfile(matlabroot, 'bin', computer('arch'))
```

To update your IDE, follow the instructions in “Specifying Engine Libraries” on page 6-20.

Note If you need to manipulate Unicode text directly in your application, the latest version of International Components for Unicode (ICU) is available online from the IBM Corporation Web site at <http://icu.sourceforge.net/download>.

Troubleshooting Engine Applications

In this section...

“Can’t Start MATLAB Engine Message” on page 6-23

“Debugging MATLAB Functions Used in Engine Applications” on page 6-23

Can’t Start MATLAB Engine Message

If you have multiple versions of MATLAB installed on your system, the version you use to build your engine applications must be the first listed in your system Path environment variable. Otherwise, MATLAB displays Can't start MATLAB engine. For information about setting the Path variable, see “Setting Run-Time Library Path on Windows” on page 6-15 or “Setting Run-Time Library Path on Linux and Macintosh” on page 6-17.

On Windows operating systems, you also need to register MATLAB as a COM server. If you have multiple versions of MATLAB, the version you are using must be the registered version. For instructions, see “Registering MATLAB Software as a COM Server” on page 6-15.

Debugging MATLAB Functions Used in Engine Applications

When creating MATLAB functions for use in engine applications, it is good practice to debug the functions in MATLAB before calling them via the engine interface.

Although you cannot use the MATLAB Editor/Debugger from an engine application, you can use the MATLAB workspace to examine variables passed to MATLAB. For example, you have the following MATLAB function:

```
function y=myfcn(x)
y=x+2;
end
```

Your engine application calls myfcn with your variable mycmxarray, as shown in the following code:

```
engPutVariable(ep, "aVar", mycmxarray);  
engEvalString(ep, "result = myfcn(aVar)");  
mycmxarrayResult = engGetVariable(ep, "result");
```

If you do not get the expected result, you can examine two possibilities: if the input, `mycmxarray`, is incorrect, or if the MATLAB function is incorrect.

To examine the input to `myfcn`, first modify the function to save the MATLAB workspace to the file `debugmyfcn.mat`.

```
function y=myfcn(x)  
save debugmyfcn.mat  
y=x+2;  
end
```

Execute your engine application, then start MATLAB and load `debugmyfcn.mat`.

```
load debugmyfcn.mat  
whos x
```

Variable `x` contains the value from `mycmxarray`. If `x` is not what you expect, debug your engine code. If `x` is correct, debug the MATLAB function. To debug `myfcn`, open the function in the MATLAB Editor/Debugger, and then call the function from the MATLAB command line:

```
myfcn(x)
```

Using Java Libraries from MATLAB

- “Overview of Java Interface” on page 7-2
- “Bringing Java Classes into MATLAB Workspace” on page 7-4
- “Creating and Using Java Objects” on page 7-13
- “Invoking Methods on Java Objects” on page 7-21
- “Working with Java Arrays” on page 7-30
- “Passing Data to Java Methods” on page 7-48
- “Handling Data Returned from Java Methods” on page 7-59
- “Read URL” on page 7-66
- “Find Internet Protocol Address” on page 7-69
- “Create and Use Phone Book” on page 7-71

Overview of Java Interface

In this section...
“Java Interface Is Integral to MATLAB” on page 7-2
“Benefits of the MATLAB Java Interface” on page 7-2
“Who Should Use the MATLAB Java Interface” on page 7-2
“To Learn More About Java Programming Language” on page 7-3
“Platform Support for JVM Software” on page 7-3

Java Interface Is Integral to MATLAB

Every installation of MATLAB includes Java Virtual Machine (JVM) software, so that you can use the Java interpreter via MATLAB commands, and you can create and run programs that create and access Java objects. For information on the MATLAB installation, see the MATLAB installation documentation for your platform.

Benefits of the MATLAB Java Interface

The MATLAB Java interface enables you to:

- Access Java API (application programming interface) class packages that support essential activities such as I/O and networking. For example, the URL class provides convenient access to resources on the Internet.
- Access third-party Java classes
- Easily construct Java objects in MATLAB workspace
- Call Java object methods, using either Java or MATLAB syntax
- Pass data between MATLAB variables and Java objects

Who Should Use the MATLAB Java Interface

The MATLAB Java interface is intended for all MATLAB users who want to take advantage of the special capabilities of the Java programming language.

For example:

- You need to access, from MATLAB, the capabilities of available Java classes.
- You are familiar with object-oriented programming in Java or in another language, such as C++.
- You are familiar with the MATLAB Class System, or with MEX-files.

To Learn More About Java Programming Language

For a complete description of the Java language and for guidance in object-oriented software design and programming, you'll need to consult outside resources.

Platform Support for JVM Software

To find out which version of JVM software is used by MATLAB on your platform, type the following at the MATLAB prompt:

```
version -java
```

Bringing Java Classes into MATLAB Workspace

In this section...

- “Introduction” on page 7-4
- “Sources of Java Classes” on page 7-4
- “Defining New Java Classes” on page 7-5
- “The Java Class Path” on page 7-5
- “Making Java Classes Available in MATLAB Workspace” on page 7-8
- “Loading Java Class Definitions” on page 7-10
- “Simplifying Java Class Names” on page 7-10
- “Locating Native Method Libraries” on page 7-11
- “Java Classes Contained in a JAR File” on page 7-12

Introduction

You can draw from an extensive collection of existing Java classes or create your own class definitions to use with MATLAB. This section explains how to go about finding the class definitions that you need or how to create classes of your own design. Once you have the classes you need, defined in either individual `.class` files, packages, or Java Archive (JAR) files, you can make them available in the MATLAB workspace. This section also describes how to specify the native method libraries used by Java code.

Sources of Java Classes

Following are Java class sources that you can use in the MATLAB workspace:

- Java built-in classes — general-purpose class packages, such as `java.util`, included in the Java language. See your Java language documentation for descriptions of these packages.
- Third-party classes — packages of special-purpose Java classes.
- User-defined classes — Java classes or subclasses of existing classes that you define. You need to use a Java language development environment to do this, as explained in the following section.

Defining New Java Classes

To define new Java classes and subclasses of existing classes, you must use a Java language development environment external to MATLAB. For information on supported versions of the Java Development Kit (JDK™) software, see the Supported and Compatible Compilers Web page.

After you create class definitions in `.java` files, use your Java compiler to produce `.class` files from them. The next step is to make the class definitions in those `.class` files available for you to use in MATLAB.

The Java Class Path

MATLAB loads Java class definitions from files that are on the Java *class path*. The class path is a series of file and directory specifications that MATLAB uses to locate class definitions. When loading a particular Java class, MATLAB searches files and directories in the order they occur on the class path until a file is found that contains that class definition. The search ends when the first definition is found.

The Java class path consists of two segments: the *static path* and the *dynamic path*. MATLAB loads the static path at startup. If you change the path you must restart MATLAB. You can load and modify the dynamic path at any time using MATLAB functions. MATLAB always searches the static path before the dynamic path.

Note Java classes on the static path should not have dependencies on classes on the dynamic path.

You can view these two path segments using the `javaclasspath` function:

```
javaclasspath
```

```
    STATIC JAVA PATH
```

```
D:\Sys0\Java\util.jar
D:\Sys0\Java\widgets.jar
D:\Sys0\Java\beans.jar
      .
      .
```

```
    DYNAMIC JAVA PATH
```

```
C:\Work\Java\ClassFiles
C:\Work\Java\mywidgets.jar
      .
      .
```

You probably want to use both the static and dynamic paths:

- Put the Java class definitions that are more stable on the static class path. Classes defined on the static path load somewhat faster than those on the dynamic path.
- Put the Java class definitions that you are likely to modify on the dynamic class path. You can make changes to the class definitions on this path without restarting MATLAB.

The Static Path

MATLAB loads the static class path at the start of each session. The static path offers better class loading performance than the dynamic path. To add folders to the static path, create the file `javaclasspath.txt`, and then restart MATLAB.

Create an ASCII file in your preferences folder named `javaclasspath.txt`. To view the location of the preferences folder, type:

```
prefdir
```

Each line in the file is the path name of a directory or jar file. For example:

```
d:\work\javaclasses
```

To simplify the specification of directories in cross-platform environments, use any of these macros: `$matlabroot`, `$arch`, and `$jre_home`.

You can also create a `javaclasspath.txt` file in your MATLAB startup folder. Classes specified in this file override classes specified in the `javaclasspath.txt` file in the preferences folder.

To disable using the `javaclasspath.txt` file, execute MATLAB with the `-nouserjavapath` option.

Note MATLAB reads the static class path only at startup. If you edit `javaclasspath.txt` or change your `.class` files while MATLAB is running, you must restart MATLAB to put those changes into effect.

The Dynamic Path

The dynamic class path can be loaded any time during a MATLAB session using the `javaclasspath` function. You can define the dynamic path (using `javaclasspath`), modify the path (using `javaaddpath` and `javarmpath`), and refresh the Java class definitions for all classes on the dynamic path (using `clear` with the keyword `java`) without restarting MATLAB.

The functions `javaaddpath` and `javaclasspath(dpath)` add entries to the dynamic class path. To avoid the possibility that the new path contains a class or package with the same name as an existing class or package, MATLAB clears all existing global variables and variables in the workspace.

Although the dynamic path offers more flexibility in changing the path, Java classes on the dynamic path might load more slowly than those on the static path.

Making Java Classes Available in MATLAB Workspace

To make your third-party and user-defined Java classes available in the MATLAB workspace, place them on either the static or dynamic Java class path, as described in the previous section, “The Java Class Path” on page 7-5.

- For classes you want on the static path, edit the `javaclasspath.txt` file.
- For classes you want on the dynamic path, use either the `javaclasspath` or the `javaaddpath` functions.

Making Individual (Unpackaged) Classes Available

To make individual classes (classes that are not part of a package) available in MATLAB, specify the full path to the directory you want to use for the `.class` file(s).

For example, to make available your compiled Java classes in the file `d:\work\javaclasses\test.class`, add the following entry to the static or dynamic class path:

```
d:\work\javaclasses
```

To put this directory on the static class path, edit the `javaclasspath.txt` file, described in “The Static Path” on page 7-6.

To put this on the dynamic class path, use the following command:

```
javaaddpath d:\work\javaclasses
```

Making Entire Packages Available

To access one or more classes belonging to a package, you need to make the entire package available to MATLAB. To do this, specify the full path to the *parent directory of the highest level directory* of the package path. This directory is the first component in the package name.

For example, if your Java class package `com.mw.tbx.ini` has its classes in directory `d:\work\com\mw\tbx\ini`, add the following directory to your static or dynamic class path:

```
d:\work
```

Making Classes in a JAR File Available

You can use the `jar` (Java Archive) tool to create a JAR file, containing multiple Java classes and packages in a compressed ZIP format. For information on `jar` and JAR files, consult your Java development documentation.

To make the contents of a JAR file available for use in MATLAB, specify the full path, *including full file name*, for the JAR file. You can also put the JAR file on the MATLAB path.

Note The path name requirement for JAR files is different than that for `.class` files and packages, for which you do not specify any filename.

For example, to make available the JAR file `e:\java\classes\utilpkg.jar`, add the following file specification to your static or dynamic class path:

```
e:\java\classes\utilpkg.jar
```

Loading a Class Using Java `Class.forName` Method

Use the `javaObjectEDT` function instead of the Java `Class.forName` method. For example, replace the following statement:

```
java.lang.Class.forName('xyz.myapp.MyClass')
```

with:

```
javaObjectEDT('xyz.myapp.MyClass')
```

Loading Java Class Definitions

Normally, MATLAB loads a Java class automatically when your code first uses it, (for example, when you call its constructor). However, there is one exception you should be aware of.

When you use the `which` function on methods defined by Java classes, the function only acts on the classes currently *loaded* into the MATLAB workspace. In contrast, `which` always operates on MATLAB classes, whether or not they are loaded.

Determining Which Classes Are Loaded

At any time during a MATLAB session, you can obtain a listing of all the Java classes that are currently loaded. To do so, use the `inmem` function as follows:

```
[M,X,J] = inmem
```

This function returns the list of Java classes in the output argument `J`. (It also returns the names of all currently loaded MATLAB functions in `M`, and the names of all currently loaded MEX-files in `X`.)

Here's a sample of output from the `inmem` function:

```
[m,x,j] = inmem;
```

MATLAB displays:

```
j =  
  'java.util.Date'  
  'com.mathworks.ide.desktop.MLDesktop'
```

Simplifying Java Class Names

Your MATLAB commands can refer to any Java class by its fully qualified name, which includes its package name. For example, the following are fully qualified names:

- `java.lang.String`
- `java.util.Enumeration`

A fully qualified name can be long, making commands and functions, such as constructors, cumbersome to edit and to read. You can refer to classes by the class name alone (without a package name) if you first import the fully qualified name into MATLAB.

MATLAB adds all classes that you import to a list called the *import list*. You can see what classes are on that list by typing `import`, without any arguments. Your code can refer to any class on the list by class name alone.

When called from a function, `import` adds the specified classes to the import list in effect for that function. When invoked at the command prompt, `import` uses the base import list for your MATLAB environment.

For example, suppose a function contains the following statements:

```
import java.lang.String
import java.util.* java.awt.*
import java.util.Enumeration
```

Any code that follows these `import` statements can refer to the `String`, `Frame`, and `Enumeration` classes without using the package names. For example:

```
str = String('hello');      % Create java.lang.String object
frm = Frame;                % Create java.awt.Frame object
methods Enumeration        % List java.util.Enumeration methods
```

To remove the list of imported Java classes, type:

```
clear import
```

Locating Native Method Libraries

Java classes can dynamically load native methods using the Java method `java.lang.System.loadLibrary("LibFile")`. In order for the JVM software to locate the specified library file, the directory containing it must be on the Java Library Path. This path is established when the MATLAB launches the JVM software at startup.

You can augment the search path for native method libraries by creating an ASCII text file named `javalibrarypath.txt` in your preferences folder. Follow these guidelines when editing this file:

- Specify each new directory on a line by itself.
- Specify only the directory names, not the names of the DLL files. The `loadLibrary` call does this for you.
- To simplify the specification of directories in cross-platform environments, use any of these macros: `$matlabroot`, `$arch`, and `$jre_home`.

You can also create a `javalibrarypath.txt` file in your MATLAB startup folder. Libraries specified in this file override libraries specified in the `javalibrarypath.txt` file in the preferences folder.

To disable using the `javalibrarypath.txt` file, execute MATLAB with the `-nouserjavapath` option.

Java Classes Contained in a JAR File

You can access Java classes that are contained in a JAR file once you have added the JAR file to either the static or dynamic class path. See “The Java Class Path” on page 7-5 for more information on how MATLAB uses the Java class path.

For example, suppose you have a file, `myArchive.jar`, in a directory called `work` in your MATLAB root directory. You can construct the path to this file using the `matlabroot` command:

```
[matlabroot ' /work/myArchive.jar' ]
```

Add the JAR file to your dynamic class path using the `javaaddpath` function (`fullfile` adds the platform-correct directory separators):

```
javaaddpath(fullfile(matlabroot, 'work', 'myArchive.jar'))
```

You can now call the public methods in the JAR file.

Creating and Using Java Objects

In this section...

“Overview” on page 7-13

“Constructing Java Objects” on page 7-13

“Concatenating Java Objects” on page 7-16

“Saving and Loading Java Objects to MAT-Files” on page 7-17

“Finding the Public Data Fields of an Object” on page 7-18

“Accessing Private and Public Data” on page 7-18

“Determining the Class of an Object” on page 7-20

Overview

You create a Java object in the MATLAB workspace by calling one of the constructors of that class. You then use commands and programming statements to perform operations on these objects. You can also save your Java objects to a MAT-file and, in subsequent sessions, reload them into MATLAB.

Constructing Java Objects

You construct Java objects in the MATLAB workspace by calling the Java class constructor, which has the same name as the class. For example, the following constructor creates a `myDate` object:

```
myDate = java.util.Date
```

```
myDate =  
Thu Aug 23 12:58:54 EDT 2007
```

MATLAB displays information for your system.

Using the `javaObjectEDT` Function

Under certain circumstances, you might need to use the `javaObjectEDT` function to construct a Java object. The following syntax invokes the Java

constructor for class, `class_name`, with the argument list that matches `x1, ..., xn`, and returns a new object, `J`.

```
J = javaObjectEDT('class_name',x1,...,xn);
```

For example, to construct and return a Java object of class `java.lang.String`, type:

```
strObj = javaObjectEDT('java.lang.String','hello');
```

With the `javaObjectEDT` function you can:

- Use classes that have names that exceed the maximum length of a MATLAB identifier. (Call the `namelengthmax` function to obtain the maximum identifier length.)
- Specify the class for an object at run-time, for example, as input from an application user

The default MATLAB constructor syntax requires that no segment of the input class name be longer than `namelengthmax` characters. (A *class name segment* is any portion of the class name before, between, or after a dot. For example, there are three segments in class, `java.lang.String`.) Any class name segment that exceeds `namelengthmax` characters is truncated by MATLAB. In the rare case where you need to use a class name of this length, you must use `javaObjectEDT` to instantiate the class.

The `javaObjectEDT` function also allows you to specify the Java class for the object being constructed at run-time. In this situation, you call `javaObjectEDT` with a string variable in place of the class name argument.

```
class = 'java.lang.String';  
text = 'hello';  
strObj = javaObjectEDT(class, text);
```

In the usual case, when the class to instantiate is known at development time, it is more convenient to use the MATLAB constructor syntax. For example, to create a `java.lang.String` object, type:

```
strObj = java.lang.String('hello');
```

Use the `javaObjectEDT` function instead of the `Java Class.forName` method. For example, replace the following statement:

```
java.lang.Class.forName('xyz.myapp.MyClass')
```

with:

```
javaObjectEDT('xyz.myapp.MyClass')
```

Note Typically, you do not need to use `javaObjectEDT`. The default MATLAB syntax for instantiating a Java class is somewhat simpler and is preferable for most applications. Use `javaObjectEDT` primarily for the previously described cases.

Java Objects Are References in MATLAB Applications

In MATLAB, Java objects are *references* and do not adhere to MATLAB copy-on-assignment and pass-by-value rules. For example:

```
myDate = java.util.Date;  
setHours(myDate,10)  
newDate = myDate;
```

In this example, the variable `newDate` is a reference to `myDate`, not a copy of the object. Any change to the object referenced by `newDate` also changes the object at `myDate`. This happens if the object is changed by MATLAB code or by Java code.

The following example shows that `myDate` and `newDate` are references to the same object. When you change the hour via one reference (`newDate`), the change is reflected through the other reference (`myDate`), as well.

```
setHours(newDate,8)  
myDate.getHours
```

```
ans =  
    8
```

Concatenating Java Objects

You can concatenate Java objects in the same way that you concatenate native MATLAB types. You use either the `cat` function or the `[]` operators to tell MATLAB to assemble the enclosed objects into a single object.

Concatenating Objects of the Same Class

If all of the objects being operated on are of the same Java class, the concatenation of those objects produces an array of objects from the same class.

In the following example, the `cat` function concatenates two objects of the class `java.awt.Integer`. The class of the result is also `java.awt.Integer`.

```
value1 = java.lang.Integer(88);  
value2 = java.lang.Integer(45);  
cat(1, value1, value2)
```

```
ans =  
java.lang.Integer[]:  
    [88]  
    [45]
```

Concatenating Objects of Unlike Classes

When you concatenate objects of unlike classes, MATLAB finds one class from which all of the input objects inherit, and makes the output an instance of this class. MATLAB selects the lowest common parent in the Java class hierarchy as the output class.

For example, concatenating objects of `java.lang.Byte`, `java.lang.Integer`, and `java.lang.Double` creates an object of `java.lang.Number`, since this is the common parent to the three input classes.

```
byte = java.lang.Byte(127);  
integer = java.lang.Integer(52);  
double = java.lang.Double(7.8);  
[byte; integer; double]
```

```
ans =
```

```
java.lang.Number[]:
 [ 127]
 [ 52]
 [7.8000]
```

If there is no common, lower level parent, then the resultant class is `java.lang.Object`, which is the root of the entire Java class hierarchy.

```
byte = java.lang.Byte(127);
point = java.awt.Point(24,127);
[byte; point]
```

```
ans =
java.lang.Object[]:
 [ 127]
 [1x1 java.awt.Point]
```

Saving and Loading Java Objects to MAT-Files

Use the `save` function to save a Java object to a MAT-file. Use the `load` function to load it back into MATLAB from that MAT-file. To save a Java object to a MAT-file, and to load the object from the MAT-file, make sure that the object and its class meet all of the following criteria:

- The class implements the `Serializable` interface (part of the Java API), either directly or by inheriting it from a parent class. Any embedded or otherwise referenced objects must also implement `Serializable`.
- The definition of the class is not changed between saving and loading the object. Any change to the data fields or methods of a class prevents the loading (deserialization) of an object that was constructed with the old class definition.
- Either the class does not have any transient data fields, or the values in transient data fields of the object to be saved are not significant. Values in transient data fields are never saved with the object.

If you define your own Java classes, or subclasses of existing classes, you can follow the criteria above to enable objects of the class to be saved and loaded in MATLAB. For details on defining classes to support serialization, consult your Java development documentation.

Finding the Public Data Fields of an Object

To list the public fields that belong to a Java object, use the `fieldnames` function, which takes either of these forms.

```
names = fieldnames(obj)
names = fieldnames(obj, '-full')
```

Calling `fieldnames` without `-full` returns the names of all the data fields (including inherited) on the object. With the `-full` qualifier, `fieldnames` returns the full description of the data fields defined for the object, including type, attributes, and inheritance information.

For example, create an `Integer` object with the command:

```
value = java.lang.Integer(0);
```

To see a full description of the data fields of `value`, type:

```
fieldnames(value, '-full')

ans =
    'static final int MIN_VALUE'
    'static final int MAX_VALUE'
    'static final java.lang.Class TYPE'
    'static final int SIZE'
```

Accessing Private and Public Data

Java API classes provide accessor methods you can use to read from and, where allowed, to modify *private* data fields. These are sometimes referred to as *get* and *set* methods, respectively.

Some Java classes have *public* data fields, which your code can read or modify directly. To access these fields, use the syntax `object.field`.

Examples

The `java.awt.Frame` class provides an example of access to both private and public data fields. This class has the read accessor method `getSize`, which returns a `java.awt.Dimension` object. The `Dimension` object has data fields `height` and `width`, which are public and therefore directly accessible. For example, to access this data, type:

```
frame = java.awt.Frame;
frameDim = getSize(frame);
height = frameDim.height;
frameDim.width = 42;
```

The programming examples in this chapter also contain calls to data field accessors. For instance, the sample code for “Find Internet Protocol Address” on page 7-69 uses calls to accessors on a `java.net.InetAddress` object.

```
hostname = address.getHostName;
ipaddress = address.getHostAddress;
```

Accessing Data from a Static Field

In a Java language program, a *static data field* is a field that applies to an entire class of objects. Static fields are most commonly accessed in relation to the class name itself. For example, the following code accesses the `TYPE` field of the `Integer` class by referring to it in relation to the package and class names, `java.lang.Integer`, rather than an object instance.

```
thisType = java.lang.Integer.TYPE;
```

In MATLAB, you can use that same syntax. Or you can refer to the `TYPE` field in relation to an instance of the class. The following example creates an instance of `java.lang.Integer` called `value`, and then accesses the `TYPE` field using the name `value` rather than the package and class names.

```
value = java.lang.Integer(0);
thatType = value.TYPE
```

```
thatType =
int
```

Assigning to a Static Field

You can assign values to static fields by using a static set method of the class, or by making the assignment in reference to an instance of the class. For more information, see “Accessing Data from a Static Field” on page 7-19. You can assign value to the field `staticFieldName` in the following example by referring to this field in reference to an instance of the class.

```
objectName = java.className;
```

```
objectName.staticFieldName = value;
```

Note MATLAB does not allow assignment to static fields using the class name itself.

Determining the Class of an Object

To find the class of a Java object, use the query form of the `class` function. After execution of the following example, `myClass` contains the name of the package and class that the object `value` instantiates.

```
value = java.lang.Integer(0);  
myClass = class(value)
```

```
myClass =  
java.lang.Integer
```

Because this form of `class` also works on MATLAB objects, it does not, in itself, tell you whether it is a Java class. To determine the type of class, use the `isjava` function, which returns 1 if `obj` is a Java object, and 0 if it is not. For example, type:

```
isjava(value)
```

```
ans =  
    1
```

To find out if an object is an instance of a specified class, use the `isa` function, which returns 1 if the object is an instance of the class. The class can be a MATLAB built-in or user-defined class, as well as a Java class. For example, type:

```
isa(value, 'java.lang.Integer')
```

```
ans =  
    1
```

Invoking Methods on Java Objects

In this section...

- “Calling Syntax” on page 7-21
- “Obtaining Information About Methods” on page 7-23
- “Java Methods That Affect MATLAB Commands” on page 7-27
- “How MATLAB Handles Undefined Methods” on page 7-28
- “How MATLAB Handles Java Exceptions” on page 7-29
- “Method Execution in MATLAB” on page 7-29

Calling Syntax

- “Java Calling Syntax” on page 7-21
- “MATLAB Calling Syntax” on page 7-22
- “Calling Syntax for Static Methods of Java Classes” on page 7-22
- “Using the javaMethod Function” on page 7-22

Java Calling Syntax

The Java syntax to call methods on Java objects:

```
object.method(arg1, ..., argn)
```

In the following example, `myDate` is a `java.util.Date` object, and `getHours` and `setHours` are methods of that object.

```
myDate = java.util.Date;  
myDate.setHours(3)  
myDate.getHours
```

```
ans =  
    3
```

MATLAB Calling Syntax

The MATLAB syntax to call methods on Java objects:

```
method(object, arg1, ..., argn)
```

The following example shows how to call the `getHours` and `setHours` methods on a `java.util.Date` object.

```
m1Date = java.util.Date;  
setHours(m1Date, 3)  
getHours(m1Date)
```

```
ans =  
    3
```

Calling Syntax for Static Methods of Java Classes

To invoke a static method on a Java class, use the Java syntax:

```
class.method(arg1, ..., argn)
```

For example, call the static method, `isNaN`:

```
java.lang.Double.isNaN(2.2)
```

```
ans =  
    0
```

Using the `javaMethod` Function

The MATLAB `javaMethod` function enables you to:

- Use Java methods with names that exceed the maximum length of a MATLAB identifier. (Call the `namelengthmax` function to obtain the maximum identifier length.)
- Specify a Java method to invoke at run-time.

For example, your code calls `javaMethod` with a string variable in place of the `method` argument. When you use `javaMethod` to invoke a static method, you can also use a string variable in place of the class name argument.

Note The MATLAB syntax is the preferred syntax for invoking a Java method. Use `javaMethod` for these special cases only.

Obtaining Information About Methods

MATLAB provides functions to obtain information related to the Java methods you are working with. You can request a list of all of the methods that are implemented by any class. The list might be accompanied by other method information such as argument types and exceptions. You can also request a listing of every Java class that you loaded into MATLAB that implements a specified method.

Methodsview: Displaying a Listing of Java Methods

If you want to know what methods are implemented by a particular Java (or MATLAB) class, use the `methodsview` function. Specify the class name (along with its package name, for Java classes) in the command line. If you have imported the package that defines this class, then the class name alone suffices.

The following command lists information on all methods in the `java.awt.MenuItem` class. Type:

```
methodsview java.awt.MenuItem
```

A new window appears, listing one row of information for each method in the class.

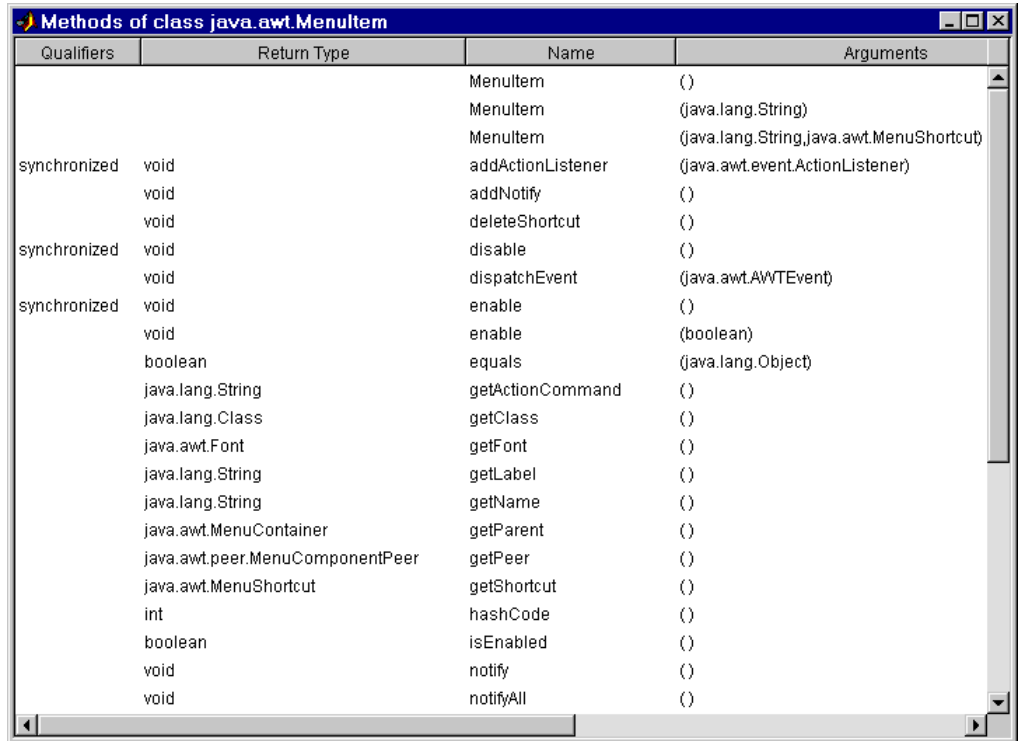

Each row in the window displays up to six fields of information describing the method. The following table lists the fields displayed in the `methodsview` window along with a description and examples of each field type.

Fields Displayed in the `Methodsview` Window

Field Name	Description	Examples
Qualifiers	Method type qualifiers	abstract, synchronized
Return Type	Type returned by the method	void, java.lang.String

Fields Displayed in the Methodsview Window (Continued)

Field Name	Description	Examples
Name	Method name	addActionListener, dispatchEvent
Arguments	Types of arguments passed to method	boolean, java.lang.Object
Other	Other relevant information	throws java.io.IOException
Inherited From	Parent of the specified class	java.awt.MenuComponent

Using the Methods Function on Java Classes

The `methods` function returns information on methods of MATLAB and Java classes.

Use `methods` without the `'-full'` qualifier to return the names of all the methods (including inherited methods) of the class. Names of overloaded methods are listed only once.

With the `'-full'` qualifier, `methods` returns a listing of the method names (including inherited methods) along with attributes, argument lists, and inheritance information on each. Each overloaded method is listed separately.

For example, display a full description of all methods of the `java.awt.Dimension` object.

```
methods java.awt.Dimension -full
```

```
Methods for class java.awt.Dimension:
Dimension()
Dimension(java.awt.Dimension)
Dimension(int,int)
java.lang.Class getClass() % Inherited from java.lang.Object
int hashCode() % Inherited from java.lang.Object
boolean equals(java.lang.Object)
java.lang.String toString()
```

```
void notify() % Inherited from java.lang.Object
void notifyAll() % Inherited from java.lang.Object
void wait(long) throws java.lang.InterruptedException
    % Inherited from java.lang.Object
void wait(long,int) throws java.lang.InterruptedException
    % Inherited from java.lang.Object
void wait() throws java.lang.InterruptedException
    % Inherited from java.lang.Object
java.awt.Dimension getSize()
void setSize(java.awt.Dimension)
void setSize(int,int)
```

Determining What Classes Define a Method

You can use the `which` function to display the fully qualified name (package and class name) of a method implemented by a *loaded* Java class. With the `-all` qualifier, the `which` function finds all classes with a method of the name specified.

Suppose, for example, that you want to find the package and class name for the `concat` method, with the `String` class currently loaded. Use the command:

```
which concat
java.lang.String.concat % String method
```

If the `java.lang.String` class has not been loaded, the same `which` command would give the output:

```
which concat
concat not found.
```

If you use `which -all equals`, with the `String` and `java.awt.Frame` classes loaded, you see the following display.

```
which -all equals
java.lang.String.equals % String method
java.awt.Frame.equals % Frame method
com.mathworks.ide.desktop.MLDesktop.equals % MLDesktop method
```

The `which` function operates differently on Java classes than it does on MATLAB classes. MATLAB classes are always displayed by `which`, whether

or not they are loaded. This is not true for Java classes. You can find out which Java classes are currently loaded by using the command `[m,x,j]=inmem`, described in “Determining Which Classes Are Loaded” on page 7-10.

For a description of how Java classes are loaded, see “Making Java Classes Available in MATLAB Workspace” on page 7-8.

Java Methods That Affect MATLAB Commands

MATLAB commands that operate on Java objects and arrays make use of the methods that are implemented within, or inherited by, these objects’ classes. There are some MATLAB commands that you can alter somewhat in behavior by changing the Java methods that they rely on.

Changing the Effect of `disp` and `display`

You can use the `disp` function to display the value of a variable or an expression in MATLAB. Terminating a command line without a semicolon also calls the `disp` function. You can also use `disp` to display a Java object in MATLAB.

When `disp` operates on a Java object, MATLAB formats the output using the `toString` method of the class to which the object belongs. If the class does not implement this method, then an inherited `toString` method is used. If no intermediate ancestor classes define this method, it uses the `toString` method defined by the `java.lang.Object` class. You can override inherited `toString` methods in classes that you create by implementing such a method within your class definition. In this way, you can change the way MATLAB displays information regarding the objects of the class.

Changing the Effect of `isequal`

The MATLAB `isequal` function compares two or more arrays for equality in type, size, and contents. This function can also be used to test Java objects for equality.

When you compare two Java objects using `isequal`, MATLAB performs the comparison using the Java method, `equals`. MATLAB first determines the class of the objects specified in the command, and then uses the `equals` method implemented by that class. If it is not implemented in this class, then

an inherited `equals` method is used. This is the `equals` method defined by the `java.lang.Object` class if no intermediate ancestor classes define this method.

You can override inherited `equals` methods in classes that you create by implementing such a method within your class definition. In this way, you can change the way MATLAB performs comparison of the members of this class.

Changing the Effect of `double` and `char`

You can also define your own Java methods `toDouble` and `toChar` to change the output of the MATLAB `double` and `char` functions. For more information, see “Converting to the MATLAB `double` Type” on page 7-61 and “Converting to the MATLAB `char` Type” on page 7-62.

How MATLAB Handles Undefined Methods

If your MATLAB command invokes a nonexistent method on a Java object, MATLAB looks for a function with the same name. If MATLAB finds a function of that name, it attempts to invoke it. If MATLAB does not find a function with that name, it displays a message stating that it cannot find a method by that name for the class.

For example, MATLAB has a function named `size`, and the Java API `java.awt.Frame` class also has a `size` method. If you call `size` on a `Frame` object, the `size` method defined by `java.awt.Frame` is executed. However, if you call `size` on an object of `java.lang.String`, MATLAB does not find a `size` method for this class. It executes the MATLAB `size` function instead.

```
string = java.lang.String('hello');  
size(string)
```

```
ans =  
    1    1
```

Note When you define a Java class for use in MATLAB, avoid giving any of its methods the same name as a MATLAB function.

How MATLAB Handles Java Exceptions

Use the `matlab.exception.JavaException` class to handle Java exceptions.

Method Execution in MATLAB

When calling a `main` method from MATLAB, the method returns as soon as it executes its last statement, even if the method creates a thread that is still executing. In other environments, the `main` method does not return until the thread completes execution.

You, therefore, need to be cautious when calling `main` methods from MATLAB, particularly `main` methods that launch GUIs. `main` methods are usually written assuming they are the entry point to application code. When called from MATLAB this is not the case, and the fact that other Java GUI code might be already running can lead to problems.

Working with Java Arrays

In this section...

- “Introduction” on page 7-30
- “How MATLAB Represents the Java Array” on page 7-30
- “Creating an Array of Objects in MATLAB” on page 7-35
- “Accessing Elements of a Java Array” on page 7-37
- “Assigning to a Java Array” on page 7-41
- “Concatenating Java Arrays” on page 7-44
- “Creating a New Array Reference” on page 7-46
- “Creating a Copy of a Java Array” on page 7-46

Introduction

You can pass singular Java objects to and from methods or you might pass them in an array, providing the method expects them in that form. This array must either be a Java array (returned from another method call or created within the MATLAB) or, under certain circumstances, a MATLAB cell array. This section describes how to create and manipulate Java arrays in MATLAB. Later sections will describe how to use MATLAB cell arrays in calls to Java methods.

Note The term *dimension* here refers more to the number of subscripts required to address the elements of an array than to its length, width, and height characteristics. For example, a 5-by-1 array is referred to as being one-dimensional, as its individual elements can be indexed into using only one array subscript.

How MATLAB Represents the Java Array

The term *Java array* refers to any array of Java objects returned from a call to a Java class constructor or method. You may also construct a Java array within MATLAB using the `javaArray` function. The structure of a Java array is significantly different from that of a MATLAB matrix or array. MATLAB

hides these differences whenever possible, allowing you to operate on the arrays using the usual MATLAB command syntax. Just the same, it may be helpful to keep the following differences in mind as you work with Java arrays.

Representing More Than One Dimension

An array in the Java language is strictly a one-dimensional structure because it is measured only in length. If you want to work with a two-dimensional array, you can create an equivalent structure using an array of arrays. To add further dimensions, you add more levels to the array, making it an array of arrays of arrays, and so on. You might want to use such multilevel arrays when working in MATLAB as it is a matrix and array-based programming language.

MATLAB makes it easy for you to work with multilevel Java arrays by treating them like the matrices and multidimensional arrays that are a part of the language itself. You access elements of an array of arrays using the same MATLAB syntax that you use if you are handling a matrix. If you add more levels to the array, MATLAB can access and operate on the structure as if it is a multidimensional MATLAB array.

The left side of the following figure shows Java arrays of one, two, and three dimensions. To the right of each is the way the same array is represented to you in MATLAB. Note that single-dimension arrays are represented as a column vector.

Array Access from Java

Array Access from MATLAB



Simple Array

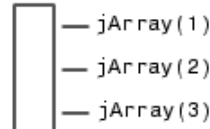

One-dimensional Array



Array of Arrays

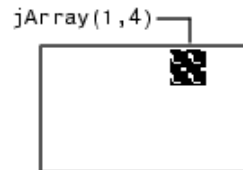

Two-Dimensional Array

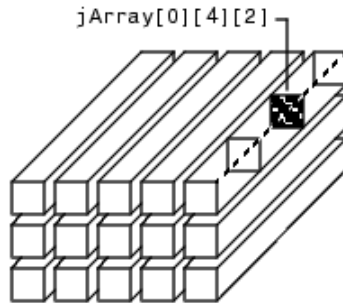

Array of Arrays of Arrays

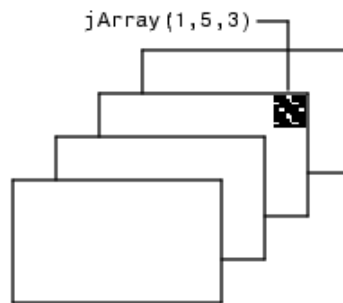

Three-Dimensional Array

Array Indexing

Java array indexing is different than MATLAB array indexing. Java array indices are zero-based, MATLAB array indices are one-based. In Java programming, you access the elements of array `y` of length `N` using `y[0]`

through `y[N-1]`. When working with this array in MATLAB, you access these same elements using the MATLAB indexing style of `y(1)` through `y(N)`. Thus, if you have a Java array of 10 elements, the seventh element is obtained using `y(7)`, and not `y[6]` as you use when writing a Java language program.

The Shape of the Java Array

A Java array can be different from a MATLAB array in its overall *shape*. A two-dimensional MATLAB array maintains a rectangular shape, as each row is of equal length and each column of equal height. The Java counterpart of this, an array of arrays, does not necessarily hold to this rectangular form. Each individual lower level array may have a different length.

Such an array structure is pictured below. This is an array of three underlying arrays of different lengths. The terms *jagged* or *ragged* are commonly used to describe this arrangement of array elements as the array ends do not match up evenly. When a Java method returns an array with this type of structure, it is stored in a cell array by MATLAB.



Interpreting the Size of a Java Array

When the MATLAB `size` function is applied to a simple Java array, the number of rows returned is the length of the Java array and the number of columns is always 1.

Determining the size of a Java array of arrays is not so simple. The potentially ragged shape of an array returned from a Java method makes it impossible to size the array in the same way as for a rectangular matrix. In a ragged Java array, there is no one value that represents the size of the lower level arrays.

When the `size` function is applied to a Java array of arrays, the resulting value describes the top level of the specified array. For the Java array:

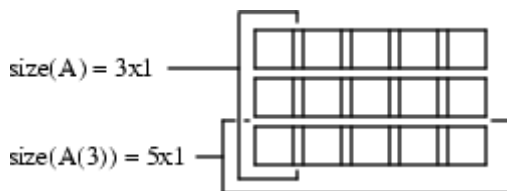

`size(A)` returns the dimensions of the highest array level of A. The highest level of the array has a size of 3-by-1.

```
size(A)
```

```
ans =
     3     1
```

To find the size of a lower level array, say the five-element array in row 3, refer to the row explicitly.

```
size(A(3))
```

```
ans =
     5     1
```

You can specify a dimension in the `size` command using the following syntax. However, you will probably find this useful only for sizing the first dimension, `dim=1`, as this will be the only non-unary dimension.

```
m = size(X,dim)
size(A, 1)
```

```
ans =
     3
```

Interpreting the Number of Dimensions of a Java Arrays

For Java arrays, whether they are simple one-level arrays or multilevel, the MATLAB `ndims` function always returns a value of 2 to indicate the number

of dimensions in the array. This is a measure of the number of dimensions in the top-level array, which always equals 2.

Creating an Array of Objects in MATLAB

To call a Java method that has one or more arguments defined as an array of Java objects, you must, under most circumstances, pass your objects in a Java array. You can construct an array of objects in a call to a Java method or constructor. Or you can create the array within MATLAB.

The MATLAB `javaArray` function lets you create a Java array structure that can be handled in MATLAB as a single multidimensional array. You specify the number and size of the array dimensions along with the class of objects you intend to store in it. Using the one-dimensional Java array as its primary building block, MATLAB then builds an array structure that satisfies the dimensions requested in the `javaArray` command.

Using the `javaArray` Function

To create a Java object array, use the MATLAB `javaArray` function, which has the following syntax:

```
A = javaArray('element_class', m, n, p, ...)
```

The first argument is the `'element_class'` string, which names the class of the elements in the array. You must specify the fully qualified name (package and class name). The remaining arguments (`m`, `n`, `p`, ...) are the number of elements in each dimension of the array.

An array that you create with `javaArray` is equivalent to the array that you create with the Java code.

```
A = new element_class[m][n][p]...;
```

The following command builds a Java array of four lower level arrays, each capable of holding five objects of the `java.lang.Double` class.

```
dblArray = javaArray('java.lang.Double',4,5);
```

The `javaArray` function does not deposit any values into the array elements that it creates. You must do this separately. The following MATLAB code

stores objects of the `java.lang.Double` type in the Java array `dblArray` that was just created.

```
for m = 1:4
    for n = 1:5
        dblArray(m,n) = java.lang.Double((m*10) + n);
    end
end
```

`dblArray`

```
dblArray =
java.lang.Double[][]:
    [11]    [12]    [13]    [14]    [15]
    [21]    [22]    [23]    [24]    [25]
    [31]    [32]    [33]    [34]    [35]
    [41]    [42]    [43]    [44]    [45]
```

Another Way to Create a Java Array

You can also create an array of Java objects using syntax that is more typical to MATLAB. For example, the following syntax creates a 4-by-5 MATLAB array of type double and assigns zero to each element of the array.

```
matlabArr(4,5) = 0;
```

You use similar syntax to create a Java array in MATLAB, except that you must specify the Java class name. The value being assigned, 0 in this example, is stored in the final element of the array, `javaArr(4,5)`. All other elements of the array receive the empty matrix.

```
javaArr(4,5) = java.lang.Double(0)
```

```
javaArr =
java.lang.Double[][]:
    []    []    []    []    []
    []    []    []    []    []
    []    []    []    []    []
    []    []    []    []    [0]
```

Note You cannot change the dimensions of an existing Java array as you can with a MATLAB array. The same restriction exists when working with Java arrays in the Java language. See the example below.

This example first creates a scalar MATLAB array, and then successfully modifies it to be two-dimensional.

```
matlabArr = 0;
matlabArr(4,5) = 0

matlabArr =

     0     0     0     0     0
     0     0     0     0     0
     0     0     0     0     0
     0     0     0     0     0
```

When you try this with a Java array, you get an error message. Similarly, you cannot create an array of Java arrays from a Java array, and so forth.

```
javaArr = java.lang.Double(0);
javaArr(4,5) = java.lang.Double(0);
```

```
Index exceeds Java array dimensions.
```

Accessing Elements of a Java Array

You can access elements of a Java object array by using the MATLAB array indexing syntax, `A(row,col)`. For example, to access the element of array `dblArray` located at row 3, column 4, use:

```
row3_col4 = dblArray(3,4)

row3_col4 =
34.0
```

In a Java language program, this is `dblArray[2][3]`.

You can also use MATLAB array indexing syntax to access an element in an object's data field. Suppose that `myMenuObj` is an instance of a window

menu class. This user-supplied class has a data field, `menuItemArray`, which is a Java array of `java.awt.MenuItem`. To get element 3 of this array, use the following command.

```
currentItem = myMenuObj.menuItemArray(3)
```

Using Single Subscript Indexing to Access Arrays

Elements of a MATLAB matrix are most commonly referenced using both row and column subscripts. For example, you use `x(3,4)` to reference the array element at the intersection of row 3 and column 4. Sometimes it is more advantageous to use just a single subscript. MATLAB provides this capability (see the section on “Linear Indexing” in MATLAB Mathematics).

Indexing into a MATLAB matrix using a single subscript references one element of the matrix. Using the MATLAB matrix shown here, `matlabArr(3)` returns a single element of the matrix.

```
matlabArr = [11 12 13 14 15; 21 22 23 24 25; ...  
            31 32 33 34 35; 41 42 43 44 45]
```

```
matlabArr =  
    11    12    13    14    15  
    21    22    23    24    25  
    31    32    33    34    35  
    41    42    43    44    45
```

```
matlabArr(3)
```

```
ans =  
    31
```

Indexing this way into a Java array of arrays references an entire subarray of the overall structure. Using the `dblArray` Java array, that looks the same as `matlabArr` shown above, `dblArray(3)` returns the 5-by-1 array that makes up the entire third row.

```
row3 = dblArray(3)

row3 =
java.lang.Double[]:
    [31]
    [32]
    [33]
    [34]
    [35]
```

This is a useful feature of MATLAB because it allows you to specify an entire array from a larger array structure, and then manipulate it as an object.

Using the Colon Operator

Use of the MATLAB colon operator (:) is supported in subscripting Java array references. This operator works just the same as when referencing the contents of a MATLAB array. Using the Java array of `java.lang.Double` objects shown here, the statement `dblArray(2,2:4)` refers to a portion of the lower level array, `dblArray(2)`. A new array, `row2Array`, is created from the elements in columns 2 through 4.

```
dblArray

dblArray =
java.lang.Double[][]:
    [11]    [12]    [13]    [14]    [15]
    [21]    [22]    [23]    [24]    [25]
    [31]    [32]    [33]    [34]    [35]
    [41]    [42]    [43]    [44]    [45]

row2Array = dblArray(2,2:4)

row2Array =
java.lang.Double[]:
    [22]
    [23]
    [24]
```

You also can use the colon operator in single-subscript indexing, as covered in “Using Single Subscript Indexing to Access Arrays” on page 7-38. By making

your subscript a colon rather than a number, you can convert an array of arrays into one linear array. The following example converts the 4-by-5 array `dblArray` into a 20-by-1 linear array.

```
linearArray = dblArray(:)
```

```
linearArray =  
java.lang.Double[]:  
    [11]  
    [12]  
    [13]  
    [14]  
    [15]  
    [21]  
    [22]  
    .  
    .  
    .
```

This works the same way on an N-dimensional Java array structure. Using the colon operator as a single subscripted index into the array produces a linear array composed of all of the elements of the original array.

Note Java and MATLAB arrays are stored differently in memory. This is reflected in the order they are given in a linear array. Java array elements are stored in an order that matches the *rows* of the matrix, (11, 12, 13, ... in the array shown above). MATLAB array elements are stored in an order that matches the *columns*, (11, 21, 31, ...).

Using END in a Subscript

You can use the `end` keyword in the first subscript of an access statement. The first subscript references the top-level array in a multilevel Java array structure.

Note Using `end` on lower level arrays is not valid due to the potentially ragged nature of these arrays (see “The Shape of the Java Array” on page 7-33). In this case, there is no consistent end value to be derived.

The following example displays data from the third to the last row of Java array `dblArray`.

```
last2rows = dblArray(3:end, :)

last2rows =
java.lang.Double[][]:
    [31]    [32]    [33]    [34]    [35]
    [41]    [42]    [43]    [44]    [45]
```

Assigning to a Java Array

You assign values to objects in a Java array in essentially the same way as you do in a MATLAB array. Although Java and MATLAB arrays are structured quite differently, you use the same command syntax to specify which elements you want to assign to. See “Introduction” on page 7-30 for more information on Java and MATLAB array differences.

The following example deposits the value 300 in the `dblArray` element at row 3, column 2. In a Java language program, this is `dblArray[2][1]`.

```
dblArray(3,2) = java.lang.Double(300)

dblArray =
java.lang.Double[][]:
    [11]    [ 12]    [13]    [14]    [15]
    [21]    [ 22]    [23]    [24]    [25]
    [31]    [300]    [33]    [34]    [35]
    [41]    [ 42]    [43]    [44]    [45]
```

You use the same syntax to assign to an element in an object’s data field. Continuing with the `myMenuObj` example shown in “Accessing Elements of a Java Array” on page 7-37, you assign to the third menu item in `menuItemArray` as follows.

```
myMenuObj.menuItemArray(3) = java.lang.String('Save As...');
```

Using Single Subscript Indexing for Array Assignment

You can use a single-array subscript to index into a Java array structure that has more than one dimension. Refer to “Using Single Subscript Indexing to Access Arrays” on page 7-38 for a description of this feature as used with Java arrays.

You can use single-subscript indexing to assign values to an array as well. The example below assigns a one-dimensional Java array, `onedimArray`, to a row of a two-dimensional Java array, `dblArray`. Start out by creating the one-dimensional array.

```
onedimArray = javaArray('java.lang.Double', 5);  
for k = 1:5  
    onedimArray(k) = java.lang.Double(100 * k);  
end
```

Since `dblArray(3)` refers to the 5-by-1 array displayed in the third row of `dblArray`, you can assign the entire, similarly dimensioned, 5-by-1 `onedimArray` to it.

```
dblArray(3) = onedimArray
```

```
dblArray =  
java.lang.Double[][]:  
    [ 11]    [ 12]    [ 13]    [ 14]    [ 15]  
    [ 21]    [ 22]    [ 23]    [ 24]    [ 25]  
    [100]    [200]    [300]    [400]    [500]  
    [ 41]    [ 42]    [ 43]    [ 44]    [ 45]
```

Assigning to a Linear Array

You can assign a value to *every* element of a multidimensional Java array by treating the array structure as if it were a single linear array. This entails replacing the single, numerical subscript with the MATLAB colon operator. If you start with the `dblArray` array, you can initialize the contents of every object in the two-dimensional array with the following statement.

```
dblArray(:) = java.lang.Double(0)
```

```
dblArray =  
java.lang.Double[][]:
```

```
[0] [0] [0] [0] [0]
[0] [0] [0] [0] [0]
[0] [0] [0] [0] [0]
[0] [0] [0] [0] [0]
```

You can use the MATLAB colon operator as you would when working with MATLAB arrays. The statements below assign given values to each of the four rows in the Java array, `dblArray`. Remember that each row actually represents a separate Java array in itself.

```
dblArray(1,:) = java.lang.Double(125);
dblArray(2,:) = java.lang.Double(250);
dblArray(3,:) = java.lang.Double(375);
dblArray(4,:) = java.lang.Double(500)
```

```
dblArray =
java.lang.Double[][]:
    [125] [125] [125] [125] [125]
    [250] [250] [250] [250] [250]
    [375] [375] [375] [375] [375]
    [500] [500] [500] [500] [500]
```

Assigning the Empty Matrix

When working with MATLAB arrays, you can assign the empty matrix, (that is, the 0-by-0 array denoted by `[]`) to an element of the array. For Java arrays, you can also assign `[]` to array elements. This stores the NULL value, rather than a 0-by-0 array, in the Java array element.

Subscripted Deletion

When you assign the empty matrix value to an entire row or column of a MATLAB array, you find that MATLAB actually removes the affected row or column from the array. In the example below, the empty matrix is assigned to all elements of the fourth column in the MATLAB matrix, `matlabArr`. Thus, the fourth column is completely eliminated from the matrix. This changes its dimensions from 4-by-5 to 4-by-4.

```
matlabArr = [11 12 13 14 15; 21 22 23 24 25; ...  
            31 32 33 34 35; 41 42 43 44 45]
```

```
matlabArr =  
    11    12    13    14    15  
    21    22    23    24    25  
    31    32    33    34    35  
    41    42    43    44    45
```

```
matlabArr(:,4) = []
```

```
matlabArr =  
    11    12    13    15  
    21    22    23    25  
    31    32    33    35  
    41    42    43    45
```

You can assign the empty matrix to a Java array, but the effect is different. The next example shows that, when the same operation is performed on a Java array, the structure is not collapsed; it maintains its 4-by-5 dimensions.

```
dblArray(:,4) = []
```

```
dblArray =  
java.lang.Double[][]:  
    [125]    [125]    [125]    []    [125]  
    [250]    [250]    [250]    []    [250]  
    [375]    [375]    [375]    []    [375]  
    [500]    [500]    [500]    []    [500]
```

The `dblArray` data structure is actually an array of five-element arrays of `java.lang.Double` objects. The empty array assignment placed the NULL value in the fourth element of each of the lower level arrays.

Concatenating Java Arrays

You can concatenate arrays of Java objects in the same way as arrays of other types. Java objects, however, can only be concatenated along the first or second axis. To understand how scalar Java objects are concatenated in MATLAB, see “Concatenating Java Objects” on page 7-16.

Use either the `cat` function or the square bracket (`[]`) operators. This example horizontally concatenates two Java arrays: `d1` and `d2`.

```
% Construct a 2-by-3 array of java.lang.Double.
d1 = javaArray('java.lang.Double',2,3);
for m = 1:3      for n = 1:3
d1(m,n) = java.lang.Double(n*2 + m-1);
end;            end;
```

`d1`

```
d1 =
java.lang.Double[][]:
    [2]    [4]    [6]
    [3]    [5]    [7]
    [4]    [6]    [8]
```

```
% Construct a 2-by-2 array of java.lang.Double.
d2 = javaArray('java.lang.Double',2,2);
for m = 1:3      for n = 1:2
d2(m,n) = java.lang.Double((n+3)*2 + m-1);
end;            end;
```

`d2`

```
d2 =
java.lang.Double[][]:
    [ 8]    [10]
    [ 9]    [11]
    [10]    [12]
```

```
% Concatenate the two along the second dimension.
d3 = cat(2,d1,d2)
```

```
d3 =
java.lang.Double[][]:
    [2]    [4]    [6]    [ 8]    [10]
    [3]    [5]    [7]    [ 9]    [11]
    [4]    [6]    [8]    [10]    [12]
```

Creating a New Array Reference

Because Java arrays in MATLAB are *references*, assigning an array variable to another variable results in a second reference to the array.

Consider the following example where two separate array variables reference a common array. The original array, `origArray`, is created and initialized. The statement `newArrayRef = origArray` creates a copy of this array variable. Changes made to the array referred to by `newArrayRef` also show up in the original array.

```
origArray = javaArray('java.lang.Double', 3, 4);
for m = 1:3
    for n = 1:4
        origArray(m,n) = java.lang.Double((m * 10) + n);
    end
end
```

```
origArray
```

```
origArray =
java.lang.Double[][]:
    [11]    [12]    [13]    [14]
    [21]    [22]    [23]    [24]
    [31]    [32]    [33]    [34]
```

```
%----- Make a copy of the array reference -----
newArrayRef = origArray;
newArrayRef(3,:) = java.lang.Double(0);
```

```
origArray
```

```
origArray =
java.lang.Double[][]:
    [11]    [12]    [13]    [14]
    [21]    [22]    [23]    [24]
    [ 0]    [ 0]    [ 0]    [ 0]
```

Creating a Copy of a Java Array

You can create an entirely new array from an existing Java array by indexing into the array to describe a block of elements, (or subarray), and assigning

this subarray to a variable. The assignment copies the values in the original array to the corresponding cells of the new array.

As with the example in section “Creating a New Array Reference” on page 7-46, an original array is created and initialized. But, this time, a copy is made of the array contents rather than copying the array reference. Changes made using the reference to the new array do not affect the original.

```
origArray = javaArray('java.lang.Double', 3, 4);
for m = 1:3
    for n = 1:4
        origArray(m,n) = java.lang.Double((m * 10) + n);
    end
end
```

origArray

```
origArray =
java.lang.Double[][]:
    [11]    [12]    [13]    [14]
    [21]    [22]    [23]    [24]
    [31]    [32]    [33]    [34]
```

```
% ----- Make a copy of the array contents -----
newArray = origArray(:,:);
newArray(3,:) = java.lang.Double(0);
```

origArray

```
origArray =
java.lang.Double[][]:
    [11]    [12]    [13]    [14]
    [21]    [22]    [23]    [24]
    [31]    [32]    [33]    [34]
```

Passing Data to Java Methods

In this section...

“Introduction” on page 7-48

“Conversion of MATLAB Argument Data” on page 7-48

“Passing Built-In Types” on page 7-50

“Passing String Arguments” on page 7-51

“Passing Java Objects” on page 7-52

“Other Data Conversion Topics” on page 7-55

“Passing Data to Overloaded Methods” on page 7-56

Introduction

When you make a call in MATLAB to Java code, any MATLAB types you pass in the call are converted to types native to the Java language. MATLAB performs this conversion on each argument that is passed, except for those arguments that are already Java objects. This section describes the conversion that is performed on specific MATLAB types and, at the end, also takes a look at how argument types affect calls made to overloaded methods.

If data is to be returned by the method being called, MATLAB receives this data and converts it to the appropriate MATLAB format wherever necessary. This process is covered in “Handling Data Returned from Java Methods” on page 7-59.

Conversion of MATLAB Argument Data

MATLAB data, passed as arguments to Java methods, are converted by MATLAB into types that best represent the data to the Java language. The table below shows all of the MATLAB base types for passed arguments and the Java base types defined for input arguments. Each row shows a MATLAB type followed by the possible Java argument matches, from left to right in order of closeness of the match. The MATLAB types (except cell arrays) can all be scalar (1-by-1) arrays or matrices. All of the Java types can be scalar values or arrays.

Conversion of MATLAB Types to Java Types

MATLAB Argument	Closest Type (7)	Java Input Argument (Scalar or Array)					Least Close Type (1)
		byte	short	int	long	float	
logical	boolean	byte	short	int	long	float	double
double	double	float	long	int	short	byte	boolean
single	float	double	N/A	N/A	N/A	N/A	N/A
char	String	char	N/A	N/A	N/A	N/A	N/A
uint8	byte	short	int	long	float	double	N/A
uint16	short	int	long	float	double	N/A	N/A
uint32	int	long	float	double	N/A	N/A	N/A
int8	byte	short	int	long	float	double	N/A
int16	short	int	long	float	double	N/A	N/A
int32	int	long	float	double	N/A	N/A	N/A
cell array of strings	array of String	N/A	N/A	N/A	N/A	N/A	N/A
Java object	Object	N/A	N/A	N/A	N/A	N/A	N/A
cell array of object	array of Object	N/A	N/A	N/A	N/A	N/A	N/A
MATLAB object	N/A	N/A	N/A	N/A	N/A	N/A	N/A

Type conversion of arguments passed to Java code are discussed in the following three categories. MATLAB handles each category differently.

- “Passing Built-In Types” on page 7-50
- “Passing String Arguments” on page 7-51
- “Passing Java Objects” on page 7-52

Passing Built-In Types

The Java language has eight types that are intrinsic to the language and are not represented as Java objects. These are often referred to as *built-in*, or *elemental*, types and they include `boolean`, `byte`, `short`, `long`, `int`, `double`, `float`, and `char`. MATLAB converts its own types to these Java built-in types according to the table, Conversion of MATLAB® Types to Java® Types on page 7-49. Built-in types are in the first 10 rows of the table.

When a Java method you are calling expects one of these types, you can pass it the type of MATLAB argument shown in the left-most column of the table. If the method takes an array of one of these types, you can pass a MATLAB array of the type. MATLAB converts the type of the argument to the type assigned in the method declaration.

The MATLAB code shown below creates a top-level window frame and sets its dimensions. The call to `setBounds` passes four MATLAB scalars of the `double` type to the inherited Java Frame method, `setBounds`, that takes four arguments of the `int` type. MATLAB converts each 64-bit double type to a 32-bit integer prior to making the call. Shown here is the `setBounds` method declaration followed by the MATLAB code that calls the method.

```
public void setBounds(int x, int y, int width, int height)

frame=java.awt.Frame;
frame.setBounds(200,200,800,400);
frame.setVisible(1);
```

Passing Built-In Types in an Array

To call a Java method with an argument defined as an *array* of a built-in type, you can create and pass a MATLAB matrix with a compatible base type. The following code defines a polygon by sending four x and y coordinates to the `Polygon` constructor. Two 1-by-4 MATLAB arrays of `double` are passed to `java.awt.Polygon`, which expects integer arrays in the first two arguments. Shown here is the Java method declaration followed by MATLAB code that calls the method, and then verifies the set coordinates.

```

public Polygon(int xpoints[], int ypoints[], int npoints)

poly = java.awt.Polygon([14 42 98 124], [55 12 -2 62], 4);
[poly.xpoints poly.ypoints]      % Verify the coordinates
ans =
14      55
42      12
98     -2
124     62

```

MATLAB Arrays Are Passed by Value

Since MATLAB arrays are passed by value, any changes that a Java method makes to them are not visible to your MATLAB code. If you need to access changes that a Java method makes to an array, then, rather than passing a MATLAB array, you should create and pass a Java array, which is a reference. For a description of using Java arrays in MATLAB, see “Working with Java Arrays” on page 7-30.

Note Generally, it is preferable to have methods return data that has been modified using the return argument mechanism as opposed to passing a reference to that data in an argument list.

Passing String Arguments

To call a Java method that has an argument defined as an object of class `java.lang.String`, you can pass either a `String` object that was returned from an earlier Java call or a MATLAB 1-by-n character array. If you pass the character array, MATLAB converts the array to a Java object of `java.lang.String` for you.

For a programming example, see “Read URL” on page 7-66. This shows a MATLAB character array that holds a URL being passed to the Java `URL` class constructor. The constructor, shown below, expects a Java `String` argument.

```
public URL(String spec) throws MalformedURLException
```

In the MATLAB call to this constructor, a character array specifying the URL is passed. MATLAB converts this array to a Java `String` object prior to calling the constructor.

```
url = java.net.URL(...  
    'http://archive.ncsa.uiuc.edu/demoweb/')
```

Passing Strings in an Array

When the method you are calling expects an argument of an array of type `String`, you can create such an array by packaging the strings together in a MATLAB cell array. The strings can be of varying lengths since you are storing them in different cells of the array. As part of the method call, MATLAB converts the cell array to a Java array of `String` objects.

In the following example, the `echoPrompts` method of a user-written class accepts a string array argument that MATLAB converted from its original format as a cell array of strings. The parameter list in the Java method appears as follows:

```
public String[] echoPrompts(String s[])
```

You create the input argument by storing both strings in a MATLAB cell array. MATLAB converts this structure to a Java array of `String`.

```
myaccount.echoPrompts({'Username: ', 'Password: '})  
ans =  
'Username: '  
'Password: '
```

Passing Java Objects

When calling a method that has an argument belonging to a particular Java class, you must pass an object that is an instance of that class. In the example below, the `add` method belonging to the `java.awt.Menu` class requires, as an argument, an object of the `java.awt.MenuItem` class. The method declaration for this is:

```
public MenuItem add(MenuItem mi)
```

The example operates on the frame created in the previous example in “Passing Built-In Types” on page 7-50. The second, third, and fourth lines of

code shown here add items to a menu to be attached to the existing window frame. In each of these calls to `menu1.add`, an object that is an instance of the `java.awt.MenuItem` Java class is passed.

```
menu1 = java.awt.Menu('File Options');
menu1.add(java.awt.MenuItem('New'));
menu1.add(java.awt.MenuItem('Open'));
menu1.add(java.awt.MenuItem('Save'));
```

```
menuBar=java.awt.MenuBar;
menuBar.add(menu1);
frame.setMenuBar(menuBar);
```

Handling Objects of Class `java.lang.Object`

A special case exists when the method being called takes an argument of the `java.lang.Object` class. Since this class is the root of the Java class hierarchy, you can pass objects of any class in the argument. The following hash table example passes objects belonging to different classes to a common method, `put`, which expects an argument of `java.lang.Object`. The method declaration for `put` is:

```
public synchronized Object put(Object key, Object value)
```

The following MATLAB code passes objects of different types (boolean, float, and string) to the `put` method.

```
hTable = java.util.Hashtable;
hTable.put(0, java.lang.Boolean('TRUE'));
hTable.put(1, java.lang.Float(41.287));
hTable.put(2, java.lang.String('test string'));

hTable          % Verify hash table contents
hTable =
{1.0=41.287, 2.0=test string, 0.0=true}
```

When passing arguments to a method that takes `java.lang.Object`, it is not necessary to specify the class name for objects of a built-in type. Line 3, in the example above, specifies that `41.287` is an instance of class `java.lang.Float`. You can omit this and simply say, `41.287`, as shown in the following example.

Thus, MATLAB creates each object for you, choosing the closest matching Java object representation for each argument.

The three calls to `put` from the preceding example can be rewritten as:

```
hTable.put(0, 1);  
hTable.put(1, 41.287);  
hTable.put(2, 'test string');
```

Passing Objects in an Array

The only types of object arrays that you can pass to Java methods are Java arrays and MATLAB cell arrays. MATLAB automatically converts the cell array elements to `java.lang.Object` class objects. Note that in order for a cell array to be passed from MATLAB, the corresponding argument in the Java method signature must specify `java.lang.Object` or an array of `java.lang.Object`.

If the objects are already in a Java array, either an array returned from a Java constructor or constructed in MATLAB by the `javaArray` function, then you simply pass it as the argument to the method being called. No conversion is done by MATLAB, because the argument is already a Java array.

The following example shows the `mapPoints` method of a user-written class accepting an array of `java.awt.Point` objects. The declaration for this method is:

```
public Object mapPoints(java.awt.Point p[])
```

The MATLAB code shown below creates a 4-by-1 array containing four Java `Point` objects. When the array is passed to the `mapPoints` method, no conversion is necessary because the `javaArray` function created a Java array of `java.awt.Point` objects.

```
pointObj = javaArray('java.awt.Point',4);  
pointObj(1) = java.awt.Point(25,143);  
pointObj(2) = java.awt.Point(31,147);  
pointObj(3) = java.awt.Point(49,151);  
pointObj(4) = java.awt.Point(52,176);  
  
testData.mapPoints(pointObj);
```

Handling a Cell Array of Java Objects

You create a cell array of Java objects by using the MATLAB syntax `{a1,a2,...}`. You index into a cell array of Java objects in the usual way, with the syntax `a{m,n,...}`.

The following example creates a cell array of two `Frame` objects, `frame1` and `frame2`, and assigns it to variable `frameArray`.

```
frame1 = java.awt.Frame('Frame A');
frame2 = java.awt.Frame('Frame B');

frameArray = {frame1, frame2}

frameArray =
[1x1 java.awt.Frame]    [1x1 java.awt.Frame]
```

The next statement assigns element `{1,2}` of the cell array `frameArray` to variable `f`.

```
f = frameArray {1,2}

f =
java.awt.Frame[frame2,0,0,0x0,invalid,hidden,layout =
java.awt.BorderLayout,resizable,title=Frame B]
```

Other Data Conversion Topics

There are several remaining items of interest regarding the way MATLAB converts its data to a compatible Java type. This includes how MATLAB matches array dimensions, and how it handles empty matrices and empty strings.

How Array Dimensions Affect Conversion

The term *dimension* refers to the number of subscripts required to address the elements of an array. For example, a 5-by-1 array has one dimension, because you can index individual elements using only one array subscript.

In converting MATLAB to Java arrays, MATLAB handles dimension in a special manner. For a MATLAB array, dimension can be considered as the number of nonsingleton dimensions in the array. For example, a 10-by-1 array has dimension 1, and a 1-by-1 array has dimension 0. In Java code,

dimension is determined solely by the number of nested arrays. For example, `double[][]` has dimension 2, and `double` has dimension 0.

If the Java array's number of dimensions exactly matches the MATLAB array's number of dimensions n , the conversion results in a Java array with n dimensions. If the Java array has fewer than n dimensions, the conversion drops singleton dimensions, starting with the first one, until the number of remaining dimensions matches the number of dimensions in the Java array.

Empty Matrices and Nulls

The empty matrix is compatible with any method argument for which `NULL` is a legal value in the Java language. The empty string (' ') in MATLAB translates into an empty (not `NULL`) `String` object in Java code.

Passing Data to Overloaded Methods

When you invoke an overloaded method on a Java object, MATLAB determines which method to invoke by comparing the arguments your call passes to the arguments defined for the methods. Note that in this discussion, the term *method* includes constructors. When it determines the method to call, MATLAB converts the calling arguments to Java method types according to Java conversion rules, except for conversions involving objects or cell arrays. See “Passing Objects in an Array” on page 7-54.

How MATLAB Determines the Method to Call

When your MATLAB function calls a Java method, MATLAB:

- 1** Checks to make sure that the object (or class, for a static method) has a method by that name.
- 2** Determines whether the invocation passes the same number of arguments of at least one method with that name.
- 3** Makes sure that each passed argument can be converted to the Java type defined for the method.

If all of the preceding conditions are satisfied, MATLAB calls the method.

In a call to an overloaded method, if there is more than one candidate, MATLAB selects the one with arguments that best fit the calling arguments. First, MATLAB rejects all methods that have any argument types that are incompatible with the passed arguments (for example, if the method has a double argument and the passed argument is a char).

Among the remaining methods, MATLAB selects the one with the highest fitness value, which is the sum of the fitness values of all its arguments. The fitness value for each argument is the fitness of the base type minus the difference between the MATLAB array dimension and the Java array dimension. (Array dimensionality is explained in “How Array Dimensions Affect Conversion” on page 7-55.) If two methods have the same fitness, the first one defined in the Java class is chosen.

Example – Calling an Overloaded Method

Suppose a function constructs a `java.io.OutputStreamWriter` object, `osw`, and then invokes a method on the object.

```
osw.write('Test data', 0, 9);
```

MATLAB finds that the class `java.io.OutputStreamWriter` defines three `write` methods.

```
public void write(int c);  
public void write(char[] cbuf, int off, int len);  
public void write(String str, int off, int len);
```

MATLAB rejects the first `write` method, because it takes only one argument. Then, MATLAB assesses the fitness of the remaining two `write` methods. These differ only in their first argument, as explained below.

In the first of these two `write` methods, the first argument is defined with base type, `char`. The table, Conversion of MATLAB® Types to Java® Types on page 7-49, shows that for the type of the calling argument (MATLAB `char`), Java type, `char`, has a value of 6. There is no difference between the dimension of the calling argument and the Java argument. So the fitness value for the first argument is 6.

In the other `write` method, the first argument has Java type `String`, which has a fitness value of 7. The dimension of the Java argument is 0, so the

difference between it and the calling argument dimension is 1. Therefore, the fitness value for the first argument is 6.

Because the fitness value of those two write methods is equal, MATLAB calls the one listed first in the class definition, with `char[]` first argument.

Handling Data Returned from Java Methods

In this section...
“Introduction” on page 7-59
“Conversion of Java Return Types” on page 7-59
“Built-In Types” on page 7-60
“Java Objects” on page 7-60
“Converting Objects to MATLAB Types” on page 7-61

Introduction

In many cases, data returned from a Java method is incompatible with the types operated on in the MATLAB environment. When this is the case, MATLAB converts the returned value to a type native to the MATLAB language. This section describes the conversion performed on the various types that can be returned from a call to a Java method.

Conversion of Java Return Types

The following table lists Java return types and the resulting MATLAB types. For some Java base return types, MATLAB treats scalar and array returns differently, as described following the table.

Conversion of Java Types to MATLAB Types

Java Return Type	If Scalar Return, Resulting MATLAB Type	If Array Return, Resulting MATLAB Type
boolean	logical	logical
byte	double	int8
short	double	int16
int	double	int32
long	double	int64
float	double	single

Conversion of Java Types to MATLAB Types (Continued)

Java Return Type	If Scalar Return, Resulting MATLAB Type	If Array Return, Resulting MATLAB Type
double	double	double
char	char	char

Note MATLAB converts rectangular Java arrays to arrays of the resulting type. When Java returns a nonrectangular (jagged) array, MATLAB converts it to a cell array. For more information, see “How MATLAB Represents the Java Array” on page 7-30.

Built-In Types

Java *built-in* types are described in “Passing Built-In Types” on page 7-50. This type includes `boolean`, `byte`, `short`, `long`, `int`, `double`, `float`, and `char`. When the value returned from a method call is one of these types, MATLAB converts it according to the table Conversion of Java® Types to MATLAB® Types on page 7-59.

A single numeric or `boolean` value converts to a 1-by-1 matrix of `double`, which is convenient for use in MATLAB. An array of a numeric or `boolean` return values converts each member of the array to the closest base type to minimize the required storage space. Array member conversions are listed in the right-hand column of the table.

A return value of Java type `char` converts to a 1-by-1 matrix of `char`. An array of Java `char` converts to a MATLAB array of that type.

Java Objects

When a method call returns Java objects, MATLAB leaves them in their original form. They remain as Java objects so you can continue to use them to interact with other Java methods.

The only exception to this is when the method returns data of type `java.lang.Object`. This class is the root of the Java class hierarchy and is frequently used as a catchall for objects and arrays of various types. When the method being called returns a value of the `Object` class, MATLAB converts its value according to the table Conversion of Java® Types to MATLAB® Types on page 7-59. That is, numeric and boolean objects such as `java.lang.Integer` or `java.lang.Boolean` convert to a 1-by-1 MATLAB matrix of `double`. Object arrays of these types convert to the MATLAB types listed in the right-hand column of the table. Other object types are not converted.

Converting Objects to MATLAB Types

With the exception of objects of class `Object`, MATLAB does not convert Java objects returned from method calls to a native MATLAB type. If you want to convert Java object data to a form more readily usable in MATLAB, there are a few MATLAB functions that enable you to do this. These are described in the following sections.

- “Converting to the MATLAB double Type” on page 7-61
- “Converting to the MATLAB char Type” on page 7-62
- “Converting to a MATLAB Structure” on page 7-63
- “Converting to a MATLAB Cell Array” on page 7-63

Converting to the MATLAB double Type

Using the `double` function in MATLAB, you can convert any Java object or array of objects to the MATLAB `double` type. The action taken by the `double` function depends on the class of the object you specify:

- If the object is an instance of a numeric class (`java.lang.Number` or one of the classes that inherit from that class), MATLAB uses a preset conversion algorithm to convert the object to a MATLAB `double`.
- If the object is not an instance of a numeric class, MATLAB checks the class definition to see if it implements a method called `toDouble`. MATLAB uses `toDouble` to perform its conversion of Java objects to the MATLAB `double` type. If such a method is implemented for this class, MATLAB executes it to perform the conversion.

- If you are using a class of your own design, you can write your own `toDouble` method to perform conversions on objects of that class to a MATLAB double. This enables you to specify your own means of type conversion for objects belonging to your own classes.

Note If the class of the specified object is not `java.lang.Number`, does not inherit from that `java.lang.Number`, and does not implement a `toDouble` method, then an attempt to convert the object using the `double` function results in a MATLAB error message.

The syntax for the `double` command is as follows, where `object` is a Java object or Java array of objects:

```
double(object);
```

Converting to the MATLAB char Type

With the MATLAB `char` function, you can convert `java.lang.String` objects and arrays to MATLAB character arrays.

The syntax for the `char` command is as follows, where `object` is a Java object or Java array of objects:

```
char(object);
```

If the object specified in the `char` command is not an instance of the `java.lang.String` class, MATLAB checks its class to see if it implements a method named `toChar`. If this is the case, MATLAB executes the `toChar` method of the class to perform the conversion. If you write your own class definitions, you can make use of this feature by writing a `toChar` method that performs the conversion according to your own needs.

Note If the class of the specified object is not `java.lang.String` and it does not implement a `toChar` method, an attempt to convert the object using the `char` function results in a MATLAB error message.

Converting to a MATLAB Structure

Java objects are similar to the MATLAB struct type in that many of an object's characteristics are accessible via field names defined within the object. You might want to convert a Java object into a MATLAB struct to facilitate the handling of its data in MATLAB. Use the MATLAB struct function to do this.

The syntax for the struct command is as follows, where object is a Java object or a Java array of objects:

```
struct(object);
```

The following example converts a java.awt.Polygon object into a MATLAB struct. You can access the fields of the object directly using MATLAB struct operations. The last line indexes into the array, pstruct.xpoints, to deposit a new value into the third array element.

```
polygon = java.awt.Polygon([14 42 98 124], [55 12 -2 62], 4);  
pstruct = struct(polygon)
```

```
pstruct =  
    npoints: 4  
    xpoints: [4x1 int32]  
    ypoints: [4x1 int32]
```

```
pstruct.xpoints
```

```
ans =  
    14  
    42  
    98  
    124
```

```
pstruct.xpoints(3) = 101;
```

Converting to a MATLAB Cell Array

Use the cell function to convert a Java array or Java object into a MATLAB cell array. Elements of the resulting cell array are of the MATLAB type (if any) closest to the Java array elements or Java object.

The syntax for the `cell` command is as follows, where `object` is a Java object or a Java array of objects.

```
cell(object);
```

The following example uses the `cell` command to create a MATLAB cell array in which each cell holds an array of a different type.

```
import java.lang.* java.awt.*;

% Create a Java array of double
dblArray = javaArray('java.lang.Double', 1, 10);
for m = 1:10
    dblArray(1, m) = Double(m * 7);
end

% Create a Java array of points
ptArray = javaArray('java.awt.Point', 3);
ptArray(1) = Point(7.1, 22);
ptArray(2) = Point(5.2, 35);
ptArray(3) = Point(3.1, 49);

% Create a Java array of strings
strArray = javaArray('java.lang.String', 2, 2);
strArray(1,1) = String('one');    strArray(1,2) = String('two');
strArray(2,1) = String('three'); strArray(2,2) = String('four');

% Convert each to cell arrays
cellArray = {cell(dblArray), cell(ptArray), cell(strArray)}
cellArray =
    {1x10 cell}    {3x1 cell}    {2x2 cell}

cellArray{1,1}    % Array of type double
ans =

    [7]    [14]    [21]    [28]    [35]    [42]    [49]    [56]    [63]    [70]

cellArray{1,2}    % Array of type Java.awt.Point
ans =

    [1x1 java.awt.Point]
```

```
[1x1 java.awt.Point]
[1x1 java.awt.Point]

cellArray{1,3}      % Array of type char array

ans =
    'one'      'two'
    'three'    'four'
```

Read URL

In this section...
“Overview” on page 7-66
“Description of URLdemo” on page 7-66
“Running the Example” on page 7-67

Overview

This program, `URLdemo`, opens a connection to a Web site specified by a URL (Uniform Resource Locator) for the purpose of reading text from a file at that site.

`URLdemo` constructs an object of the Java API class, `java.net.URL`, which enables convenient handling of URLs. Then, it calls a method on the URL object, to open a connection.

To read and display the lines of text at the site, `URLdemo` uses classes from the Java I/O package `java.io`. It creates an `InputStreamReader` object, and then uses that object to construct a `BufferedReader` object. Finally, it calls a method on the `BufferedReader` object to read the specified number of lines from the site.

Description of URLdemo

The major tasks performed by `URLdemo` are:

- 1 Construct a URL object.

The example first calls a constructor on `java.net.URL` and assigns the resulting object to variable `url`. The URL constructor takes a single argument, the name of the URL to be accessed, as a string. The constructor checks whether the input URL has a valid form.

```
url = java.net.URL(...  
'http://www.mathworks.com')
```

- 2 Open a connection to the URL.

The second statement of the example calls the method, `openStream`, on the URL object `url`, to establish a connection with the Web site named by the object. The method returns an `InputStream` object to variable, `is`, for reading bytes from the site.

```
is = openStream(url);
```

3 Set up a buffered stream reader.

The next two lines create a buffered stream reader for characters. The `java.io.InputStreamReader` constructor is called with the input stream `is`, to return to variable `isr` an object that can read characters. Then, the `java.io.BufferedReader` constructor is called with `isr`, to return a `BufferedReader` object to variable `br`. A buffered reader provides for efficient reading of characters, arrays, and lines.

```
isr = java.io.InputStreamReader(is);  
br = java.io.BufferedReader(isr);
```

4 Read and display lines of text.

The following statements read the lines of HTML text from the site, looking for text beginning with a paragraph tag, `<p>`. Within the MATLAB `while` loop, the `BufferedReader` method `readLine` reads each line of text (terminated by a return and/or line feed character) from the site.

```
p1 = java.lang.String('<p>');  
p2 = java.lang.String('</p>');  
s = readLine(br);  
while ~(s.startsWith(p1))  
    s = readLine(br);  
end
```

5 Display the text.

```
disp(s.substring(p1.length,s.length-p2.length))
```

Running the Example

When you run this example, you see output similar to the following.

Explore products for MATLAB, the language of technical computing, and Simulink

Find Internet Protocol Address

In this section...

“Overview” on page 7-69

“Description of resolveip” on page 7-69

“Running the Example” on page 7-70

Overview

The `resolveip` function returns either the name or address of an IP (internet protocol) host. If you pass `resolveip` a host name, it returns the IP address. If you pass `resolveip` an IP address, it returns the host name. The function uses the Java API class `java.net.InetAddress`, which enables you to find an IP address for a host name, or the host name for a given IP address, without making DNS calls.

`resolveip` calls a static method on the `InetAddress` class to obtain an `InetAddress` object. Then, it calls accessor methods on the `InetAddress` object to get the host name and IP address for the input argument. It displays either the host name or the IP address, depending on the program input argument.

Description of resolveip

The major tasks performed by `resolveip` are:

- 1 Create an `InetAddress` object.

Instead of constructors, the `java.net.InetAddress` class has static methods that return an instance of the class. The `try` statement calls one of those methods, `getByName`, passing the input argument that the user has passed to `resolveip`. The input argument can be either a host name or an IP address. If `getByName` fails, the `catch` statement displays an error message.

```
function resolveip(input)
try
  address = java.net.InetAddress.getByName(input);
```

```
catch
    error(sprintf('Unknown host %s.', input));
end
```

2 Retrieve the host name and IP address.

The example uses calls to the `getHostName` and `getHostAddress` accessor functions on the `java.net.InetAddress` object, to obtain the host name and IP address, respectively. These two functions return objects of class `java.lang.String`; use the `char` function to convert them to character arrays.

```
hostname = char(address.getHostName);
ipaddress = char(address.getHostAddress);
```

3 Display the host name or IP address.

The example uses the MATLAB `strcmp` function to compare the input argument to the resolved IP address. If it matches, MATLAB displays the host name for the Internet address. If the input does not match, MATLAB displays the IP address.

```
if strcmp(input,ipaddress)
    disp(sprintf('Host name of %s is %s', input, hostname));
else
    disp(sprintf('IP address of %s is %s', input, ipaddress));
end;
```

Running the Example

Here is an example of calling the `resolveip` function with a host name.

```
resolveip ('www.mathworks.com')
IP address of www.mathworks.com is 144.212.100.10
```

Here is a call to the function with an IP address.

```
resolveip ('144.212.100.10')
Host name of 144.212.100.10 is www.mathworks.com
```

Create and Use Phone Book

In this section...

- “Overview” on page 7-71
- “Description of Function phonebook” on page 7-72
- “Description of Function pb_lookup” on page 7-76
- “Description of Function pb_add” on page 7-77
- “Description of Function pb_remove” on page 7-78
- “Description of Function pb_change” on page 7-79
- “Description of Function pb_listall” on page 7-80
- “Description of Function pb_display” on page 7-81
- “Description of Function pb_keyfilter” on page 7-81
- “Running the phonebook Program” on page 7-82

Overview

The example’s main function, `phonebook`, can be called either with no arguments, or with one argument, which is the key of an entry that exists in the phone book. The function first determines the folder to use for the phone book file.

If no phone book file exists, it creates one by constructing a `java.io.FileOutputStream` object, and then closing the output stream. Next, it creates a data dictionary by constructing an object of the Java API class, `java.util.Properties`, which is a subclass of `java.util.Hashtable` for storing key/value pairs in a hash table. For the phonebook program, the key is a name, and the value is one or more telephone numbers.

The `phonebook` function creates and opens an input stream for reading by constructing a `java.io.FileInputStream` object. It calls `load` on that object to load the hash table contents, if it exists. If the user passed the key to an entry to look up, it looks up the entry by calling `pb_lookup`, which finds and displays it. Then, the `phonebook` function returns.

If `phonebook` was called without the `name` argument, it then displays a textual menu of the available phone book actions:

- Look up an entry
- Add an entry
- Remove an entry
- Change the phone number(s) in an entry
- List all entries

The menu also has a selection to exit the program. The function uses MATLAB functions to display the menu and to input the user selection.

The `phonebook` function iterates accepting user selections and performing the requested phone book action until the user selects the menu entry to exit. The `phonebook` function then opens an output stream for the file by constructing a `java.io.FileOutputStream` object. It calls `save` on the object to write the current data dictionary to the phone book file. It finally closes the output stream and returns.

Description of Function `phonebook`

The major tasks performed by `phonebook` are:

- 1 Determine the data folder and full filename.

The first statement assigns the phone book filename, `'myphonebook'`, to the variable `pname`. If the `phonebook` program is running on a Windows system, it calls the `java.lang.System` static method `getProperty` to find the location of the data dictionary. This is set to the user's current working folder. Otherwise, it uses MATLAB function `getenv` to determine the location, using the system variable `HOME`, which you can define beforehand to anything you like. It then assigns to `pname` the full path name, consisting of the data folder and filename `'myphonebook'`.

```
function phonebook(varargin)
pname = 'myphonebook'; % name of data dictionary
if ispc
    datadir = char(java.lang.System.getProperty('user.dir'));
```

```

else
    datadir = getenv('HOME');
end;
pbname = fullfile(datadir, pbname);

```

2 If needed, create a file output stream.

If the phonebook file does not already exist, `phonebook` asks the user whether to create a new one. If the user answers `y`, `phonebook` creates a new phone book by constructing a `FileOutputStream` object. In the try clause of a try/catch block, the argument `pbname` passed to the `FileOutputStream` constructor is the full name of the file that the constructor creates and opens. The next statement closes the file by calling `close` on the `FileOutputStream` object `FOS`. If the output stream constructor fails, the catch statement prints a message and terminates the program.

```

if ~exist(pbname)
    disp(sprintf('Data file %s does not exist.', pbname));
    r = input('Create a new phone book (y/n)?', 's');
    if r == 'y',
        try
            FOS = java.io.FileOutputStream(pbname);
            FOS.close
        catch
            error(sprintf('Failed to create %s', pbname));
        end;
    else
        return;
    end;
end;

```

3 Create a hash table.

The example constructs a `java.util.Properties` object to serve as the hash table for the data dictionary.

```
pb_hhtable = java.util.Properties;
```

4 Create a file input stream.

In a try block, the example invokes a `FileInputStream` constructor with the name of the phone book file, assigning the object to `FIS`. If the call fails, the catch statement displays an error message and terminates the program.

```
try
    FIS = java.io.FileInputStream(pbname);
catch
    error(sprintf('Failed to open %s for reading.', pbname));
end;
```

5 Load the phone book keys and close the file input stream.

The example calls `load` on the `FileInputStream` object `FIS`, to load the phone book keys and their values (if any) into the hash table. It then closes the file input stream.

```
pb_htable.load(FIS);
FIS.close;
```

6 Display the Action menu and get the user's selection.

Within a while loop, several `disp` statements display a menu of actions that the user can perform on the phone book. Then, an input statement requests the user's typed selection.

```
while 1
    disp ' '
    disp ' Phonebook Menu: '
    disp ' '
    disp ' 1. Look up a phone number'
    disp ' 2. Add an entry to the phone book'
    disp ' 3. Remove an entry from the phone book'
    disp ' 4. Change the contents of an entry in the phone book'
    disp ' 5. Display entire contents of the phone book'
    disp ' 6. Exit this program'
    disp ' '
    s = input('Please type the number for a menu selection: ','s');
```

7 Invoke the function to perform a phone book action

Still within the `while` loop, a `switch` statement provides a case to handle each user selection `s`. Each of the first five cases invokes the function to perform a phone book action.

Case 1 prompts for a name that is a key to an entry. It calls `isempty` to determine whether the user has entered a name. If a name has not been entered, it calls `disp` to display an error message. If a name has been input, it passes it to `pb_lookup`. The `pb_lookup` routine looks up the entry and, if it finds it, displays the entry contents.

```
case '1',
    name = input('Enter name to look up: ', 's');
    if isempty(name)
        disp('No name entered')
    else
        pb_lookup(pb_htable, name);
    end;
```

Case 2 calls `pb_add`, which prompts the user for a new entry and then adds it to the phone book.

```
case '2',
    pb_add(pb_htable);
```

Case 3 uses `input` to prompt for the name of an entry to remove. If a name has not been entered, it calls `disp` to display an error message. If a name has been entered, it passes it to `pb_remove`.

```
case '3',
    name=input('Enter name of entry to remove: ', 's');
    if isempty(name)
        disp('No name entered')
    else
        pb_remove(pb_htable, name);
    end;
```

Case 4 uses `input` to prompt for the name of an entry to change. If a name has not been entered, it calls `disp` to display an error message. If a name has been entered, it passes it to `pb_change`.

```
case '4',
    name=input('Enter name of entry to change: ', 's');
```

```
        if isempty(name)
            disp 'No name entered'
        else
            pb_change(pb_htable, name);
        end;
```

Case 5 calls `pb_listall` to display all entries.

```
case '5',
    pb_listall(pb_htable);
```

8 Exit by creating an output stream and saving the phone book.

If the user has selected case 6 to exit the program, a `try` statement calls the constructor for a `FileOutputStream` object, passing it the name of the phone book. If the constructor fails, the `catch` statement displays an error message.

If the object is created, the next statement saves the phone book data by calling `save` on the `Properties` object `pb_htable`, passing the `FileOutputStream` object `FOS` and a descriptive header string. It then calls `close` on the `FileOutputStream` object, and returns.

```
case '6',
    try
        FOS = java.io.FileOutputStream(pbname);
    catch
        error(sprintf('Failed to open %s for writing.',pbname));
    end;
    pb_htable.save(FOS,'Data file for phonebook program');
    FOS.close;
    return;
otherwise
    disp 'That selection is not on the menu.'
end;
```

Description of Function `pb_lookup`

Arguments passed to `pb_lookup` are the `Properties` object `pb_htable` and the name key for the requested entry. The `pb_lookup` function first calls `get` on `pb_htable` with the name key, on which support function `pb_keyfilter`

is called to change spaces to underscores. The `get` method returns the entry (or null, if the entry is not found) to variable `entry`. Note that `get` takes an argument of type `java.lang.Object` and also returns an argument of that type. In this invocation, the key passed to `get` and the entry returned from it are actually character arrays.

`pb_lookup` then calls `isempty` to determine whether `entry` is null. If it is, it uses `disp` to display a message stating that the name was not found. If `entry` is not null, it calls `pb_display` to display the entry.

```
function pb_lookup(pb_htable,name)
entry = pb_htable.get(pb_keyfilter(name));
if isempty(entry),
    disp(sprintf('The name %s is not in the phone book',name));
else
    pb_display(entry);
end
```

Description of Function `pb_add`

1 Input the entry to add.

The `pb_add` function takes one argument, the `Properties` object `pb_htable`. `pb_add` uses `disp` to prompt for an entry. Using the up arrow (^) character as a line delimiter, `input` inputs a name to the variable `entry`. Then, within a `while` loop, it uses `input` to get another line of the entry into variable `line`. If the line is empty, indicating that the user has finished the entry, the code breaks out of the `while` loop. If the line is not empty, the `else` statement appends `line` to `entry` and then appends the line delimiter. At the end, the `strcmp` checks the possibility that no input was entered and, if that is the case, returns.

```
function pb_add(pb_htable)
disp 'Type the name for the new entry, followed by Enter.'
disp 'Then, type the phone number(s), one per line.'
disp 'To complete the entry, type an extra Enter.'
name = input(':: ','s');
entry=[name '^'];
while 1
    line = input(':: ','s');
```

```
        if isempty(line)
            break;
        else
            entry=[entry line '^'];
        end;
    end;

    if strcmp(entry, '^')
        disp 'No name entered'
        return;
    end;
```

2 Add the entry to the phone book.

After the input has completed, `pb_add` calls `put` on `pb_hhtable` with the hash key `name` (on which `pb_keyfilter` is called to change spaces to underscores) and `entry`. It then displays a message that the entry has been added.

```
pb_hhtable.put(pb_keyfilter(name),entry);
disp ' '
disp(sprintf('%s has been added to the phone book.', name));
```

Description of Function `pb_remove`

1 Look for the key in the phone book.

Arguments passed to `pb_remove` are the `Properties` object `pb_hhtable` and the name `key` for the entry to remove. The `pb_remove` function calls `containsKey` on `pb_hhtable` with the name `key`, on which support function `pb_keyfilter` is called to change spaces to underscores. If `name` is not in the phone book, `disp` displays a message and the function returns.

```
function pb_remove(pb_hhtable,name)
if ~pb_hhtable.containsKey(pb_keyfilter(name))
    disp(sprintf('The name %s is not in the phone book',name))
    return
end;
```

2 Ask for confirmation and if given, remove the key.

If the key is in the hash table, `pb_remove` asks for user confirmation. If the user confirms the removal by entering `y`, `pb_remove` calls `remove` on `pb_htable` with the (filtered) name key, and displays a message that the entry has been removed. If the user enters `n`, the removal is not performed and `disp` displays a message that the removal has not been performed.

```
r = input(sprintf('Remove entry %s (y/n)? ',name), 's');
if r == 'y'
    pb_htable.remove(pb_keyfilter(name));
    disp(sprintf('%s has been removed from the phone book',name))
else
    disp(sprintf('%s has not been removed',name))
end;
```

Description of Function `pb_change`

- 1 Find the entry to change, and confirm.

Arguments passed to `pb_change` are the Properties object `pb_htable` and the name key for the requested entry. The `pb_change` function calls `get` on `pb_htable` with the name key, on which `pb_keyfilter` is called to change spaces to underscores. The `get` method returns the entry (or null, if the entry is not found) to variable `entry`. `pb_change` calls `isempty` to determine whether the entry is empty. If the entry is empty, `pb_change` displays a message that the name is added to the phone book, and allows the user to enter the phone number(s) for the entry.

If the entry is found, in the `else` clause, `pb_change` calls `pb_display` to display the entry. It then uses `input` to ask the user to confirm the replacement. If the user enters anything other than `y`, the function returns.

```
function pb_change(pb_htable,name)
entry = pb_htable.get(pb_keyfilter(name));
if isempty(entry)
    disp(sprintf('The name %s is not in the phone book', name));
    return;
else
    pb_display(entry);
    r = input('Replace phone numbers in this entry (y/n)? ', 's');
    if r ~= 'y'
        return;
```

```
        end;  
    end;
```

2 Input new phone number(s) and change the phone book entry.

`pb_change` uses `disp` to display a prompt for new phone number(s). Then, `pb_change` inputs data into variable `entry`, with the same statements described in “Description of Function `pb_lookup`” on page 7-76.

Then, to replace the existing entry with the new one, `pb_change` calls `put` on `pb_htable` with the (filtered) key name and the new entry. It then displays a message that the entry has been changed.

```
disp 'Type in the new phone number(s), one per line.'  
disp 'To complete the entry, type an extra Enter.'  
disp(sprintf(':: %s', name));  
entry=[name '^'];  
while 1  
    line = input(':: ', 's');  
    if isempty(line)  
        break;  
    else  
        entry=[entry line '^'];  
    end;  
end;  
pb_htable.put(pb_keyfilter(name),entry);  
disp ' '  
disp(sprintf('The entry for %s has been changed', name));
```

Description of Function `pb_listall`

The `pb_listall` function takes one argument, the `Properties` object `pb_htable`. The function calls `propertyNames` on the `pb_htable` object to return to `enum` a `java.util.Enumeration` object, which supports convenient enumeration of all the keys. In a `while` loop, `pb_listall` calls `hasMoreElements` on `enum`, and if it returns `true`, `pb_listall` calls `nextElement` on `enum` to return the next key. It then calls `pb_display` to display the key and entry, which it retrieves by calling `get` on `pb_htable` with the key.

```
function pb_listall(pb_hhtable)
enum = pb_hhtable.propertyNames;
while enum.hasMoreElements
    key = enum.nextElement;
    pb_display(pb_hhtable.get(key));
end;
```

Description of Function `pb_display`

The `pb_display` function takes an argument `entry`, which is a phone book entry. After displaying a horizontal line, `pb_display` calls MATLAB function `strtok` to extract the first line of the entry, up to the line delimiter (^), into `t` and the remainder into `r`. Then, within a `while` loop that terminates when `t` is empty, it displays the current line in `t`. Then it calls `strtok` to extract the next line from `r`, into `t`. When all lines have been displayed, `pb_display` indicates the end of the entry by displaying another horizontal line.

```
function pb_display(entry)
disp ' '
disp '-----'
[t,r] = strtok(entry, '^');
while ~isempty(t)
    disp(sprintf(' %s', t));
    [t,r] = strtok(r, '^');
end;
disp '-----'
```

Description of Function `pb_keyfilter`

The `pb_keyfilter` function takes an argument `key`, which is a name used as a key in the hash table, and either filters it for storage or unfilters it for display. The filter, which replaces each space in the key with an underscore (_), makes the key usable with the methods of `java.util.Properties`.

```
function out = pb_keyfilter(key)
if ~isempty(strfind(key, ' '))
    out = strrep(key, ' ', '_');
else
    out = strrep(key, '_', ' ');
end;
```

Running the phonebook Program

In this sample run, a user invokes phonebook with no arguments. The user selects menu action 5, which displays the two entries currently in the phone book (all entries are fictitious). Then, the user selects 2, to add an entry. After adding the entry, the user again selects 5, which displays the new entry along with the other two entries.

Phonebook Menu:

1. Look up a phone number
2. Add an entry to the phone book
3. Remove an entry from the phone book
4. Change the contents of an entry in the phone book
5. Display entire contents of the phone book
6. Exit this program

Please type the number for a menu selection: 5

```
-----  
Sylvia Woodland  
(508) 111-3456  
-----
```

```
-----  
Russell Reddy  
(617) 999-8765  
-----
```

Phonebook Menu:

1. Look up a phone number
2. Add an entry to the phone book
3. Remove an entry from the phone book
4. Change the contents of an entry in the phone book
5. Display entire contents of the phone book
6. Exit this program

Please type the number for a menu selection: 2

Type the name for the new entry, followed by Enter.

Then, type the phone number(s), one per line.

To complete the entry, type an extra Enter.

```
:: BriteLites Books
```

```
:: (781) 777-6868
```

```
::
```

BriteLites Books has been added to the phone book.

Phonebook Menu:

1. Look up a phone number
2. Add an entry to the phone book
3. Remove an entry from the phone book
4. Change the contents of an entry in the phone book
5. Display entire contents of the phone book
6. Exit this program

Please type the number for a menu selection: 5

```
-----  
BriteLites Books  
(781) 777-6868  
-----
```

```
-----  
Sylvia Woodland  
(508) 111-3456  
-----
```

```
-----  
Russell Reddy  
(617) 999-8765  
-----
```

Using .NET Libraries from MATLAB

- “Overview Using .NET from MATLAB” on page 8-3
- “Getting Started with .NET” on page 8-8
- “Using a .NET Object” on page 8-14
- “Using .NET Properties” on page 8-17
- “Using .NET Methods in MATLAB” on page 8-19
- “Working with .NET Events in MATLAB” on page 8-25
- “Using Arrays with .NET Applications” on page 8-27
- “Pass Jagged Arrays” on page 8-31
- “.NET Delegates in MATLAB” on page 8-35
- “.NET Enumerations in MATLAB” on page 8-46
- “.NET Generic Classes in MATLAB” on page 8-61
- “Troubleshooting Security Policy Settings From Network Drives” on page 8-72
- “Access a Simple .NET Class” on page 8-73
- “Load a Global .NET Assembly” on page 8-79
- “Pass Numeric Arguments” on page 8-80
- “Pass System.String Arguments” on page 8-81
- “Pass System.Enum Arguments” on page 8-83
- “Pass System.Nullable Arguments” on page 8-86

- “Set Static .NET Properties” on page 8-91
- “Use .NET Properties That Take Arguments” on page 8-93
- “MATLAB Does Not Display Protected Properties” on page 8-94
- “Examples Using .NET Methods” on page 8-95
- “Call .NET Methods with Optional Arguments” on page 8-100
- “Pass Cell Arrays of .NET Data” on page 8-104
- “An Assembly is a Library of .NET Classes” on page 8-107
- “Convert Nested System.Object Arrays” on page 8-108
- “Passing Data to .NET Objects” on page 8-109
- “Handling Data Returned from .NET Objects” on page 8-117
- “Work with Microsoft® Excel® Spreadsheets Using .NET” on page 8-123
- “Work with Microsoft Word Documents Using .NET” on page 8-125

Overview Using .NET from MATLAB

In this section...

“What Is the Microsoft .NET Framework?” on page 8-3

“Benefits of the MATLAB .NET Interface” on page 8-3

“Why Use the MATLAB .NET Interface?” on page 8-3

“Limitations to .NET Support” on page 8-4

“What’s the Difference Between the MATLAB .NET Interface and MATLAB® Builder™ NE?” on page 8-5

“System Requirements” on page 8-6

“Using a .NET assembly in MATLAB” on page 8-6

“To Learn More About the .NET Framework” on page 8-6

What Is the Microsoft .NET Framework?

The Microsoft .NET Framework is an integral Windows component that provides a large body of precoded solutions to common program requirements, and manages the execution of programs written specifically for the Framework.

MATLAB supports the .NET Framework on the Windows platform only.

Benefits of the MATLAB .NET Interface

The MATLAB .NET interface enables you to:

- Create instances of .NET classes.
- Interact with .NET applications via their class members.

Why Use the MATLAB .NET Interface?

Use the MATLAB .NET interface to take advantage of the capabilities of the Microsoft .NET Framework. For example:

- You have a professionally developed .NET assembly and want to use it to do certain operations, such as access hardware.

- You want to leverage the capabilities of programming in .NET (for example, you have existing C# programs).
- You want to access existing Microsoft-supplied classes for .NET.

The speech synthesizer class, available in .NET Framework Version 3.0 and above, is an example of a ready-to-use feature. Create the following `Speak` function in MATLAB:

```
function Speak(text)
NET.addAssembly('System.Speech');
speak = System.Speech.Synthesis.SpeechSynthesizer;
speak.Volume = 100;
Speak(speak, text);
end
```

For an example rendering text to speech, type:

```
Speak('You can use .NET Libraries in MATLAB');
```

Limitations to .NET Support

MATLAB supports the .NET features C# supports, except for the limits noted in the following table.

Features Not Supported in MATLAB
Cannot use <code>ClassName.propertyname</code> syntax to set static properties. Use <code>NET.setStaticProperty</code> instead.
Unloading an assembly
Passing a structure array, sparse array, or complex number to a .NET property or method
Subclassing .NET classes from MATLAB
Accessing nonpublic class members
Displaying generic methods using <code>methods</code> or <code>methodsview</code> functions. For a workaround, see “Display .NET Generic Methods Using Reflection” on page 8-68.

Features Not Supported in MATLAB

Creating an instance of a nested class. For a workaround, see “Working With Nested Classes” on page 8-12.

Saving (serializing) .NET objects into a MAT-file

Creating .NET arrays with a specific lower bound

Concatenating multiple .NET objects into an array

Implementing interface methods

Hosting .NET controls in figure windows

Casting operations

Calling constructors with ref or out type arguments

Using `System.Console.WriteLine` to write text to the command window

Pointer type arguments, function pointers, `Dllimport` keyword

.NET remoting

Using the MATLAB `:` (colon) operator in a `foreach` iteration

Adding event listeners to .NET events defined in static classes

Handling .NET events with signatures that do not conform to the standard signature

Creating empty .NET objects

Creating .NET objects that do not belong to a namespace

What’s the Difference Between the MATLAB .NET Interface and MATLAB Builder NE?

The MATLAB .NET interface is for MATLAB users who want to use .NET assemblies in MATLAB.

MATLAB Builder™ NE packages MATLAB functions so that .NET programmers can access them. It brings MATLAB into .NET applications. For more information about this product, see the product link at <http://www.mathworks.com/help/>.

System Requirements

The MATLAB interface to .NET is available on the Windows platform only.

You must have the Microsoft .NET Framework installed on your system.

The MATLAB interface requires the .NET Framework Version 4.0 and above. The interface continues to support assemblies built on Framework 2.0 and above. To determine if your system has the supported framework, use the `NET.IsNETSupported` function.

To use a .NET application, refer to your vendor's product documentation for information about how to install the program and for details about its functionality.

MATLAB Configuration File

MATLAB provides a configuration file, `MATLAB.exe.config`, in your `matlabroot/bin/arch` folder. With this file, MATLAB loads the latest core assemblies available on your system. You can modify and use the configuration file at your own risk. For additional information on elements that can be used in the configuration file, please visit the Configuration File Schema for the .NET Framework Web page at <http://msdn.microsoft.com/en-us/library/1fk1t1t0.aspx>.

Using a .NET assembly in MATLAB

For an example of using .NET in MATLAB, see:

- “Getting Started with .NET” on page 8-8

For detailed information, see:

- “Loading .NET Assemblies into MATLAB” on page 8-11
- “Using a .NET Object” on page 8-14

To Learn More About the .NET Framework

For a complete description of the .NET Framework, you need to consult outside resources.

One source of information is the Microsoft Developer Network. Search the .NET Framework Development Center at <http://msdn.microsoft.com/en-us/netframework/aa496123> for the term “.NET Framework Class Library”. The .NET Framework Class Library is a programming reference manual. Many examples in this documentation refer to classes in this library. There are different versions of the .NET Framework documentation, so be sure to refer to the version that is on your system. See “System Requirements” on page 8-6 for information about version support in MATLAB.

Getting Started with .NET

In this section...

“What is an Assembly?” on page 8-8

“.NET Terminology” on page 8-9

“Simplifying .NET Class Names” on page 8-10

“Loading .NET Assemblies into MATLAB” on page 8-11

“Handling Exceptions” on page 8-12

“Working With Nested Classes” on page 8-12

What is an Assembly?

Assemblies are the building blocks of .NET Framework applications; they form the fundamental unit of deployment, version control, reuse, activation scoping, and security permissions. An *assembly* is a collection of types and resources built to work together and form a logical unit of functionality.

To work with a .NET application, you need to make its assemblies visible to MATLAB. How you do this depends on how the assembly is deployed, either privately or globally.

- A *global* assembly is shared among applications and installed in a common directory, called the *Global Assembly Cache* (GAC).
- A *private* assembly is used by a single application.

To load a global assembly into MATLAB, use the short name of the assembly, which is the file name without the extension. To load a private assembly, you need the *full path* (folder and file name with extension) of the assembly. This information is in the your product’s vendor documentation for the assembly. Refer to the vendor documentation for everything you need to know to use your product.

The following assemblies from the .NET Framework class library are available at startup. MATLAB dynamically loads them the first time you type “NET.” or “System.”.

- `mscorlib.dll`
- `system.dll`

To use any other .NET assembly, load the assembly using the `NET.addAssembly` command. After loading the assembly, you can work with the classes defined by the assembly.

For an example showing you how to find the information you need to work with assemblies, see:

- “Access a Simple .NET Class” on page 8-73

For detailed information, see:

- “Loading .NET Assemblies into MATLAB” on page 8-11
- “Using a .NET Object” on page 8-14

.NET Terminology

A *namespace* is a way to group identifiers. A namespace can contain other namespaces. In MATLAB, a namespace is a package. In MATLAB, a .NET type is a class.

The syntax `namespace.ClassName` is known as a *fully qualified name*.

.NET Framework System Namespace

`System` is the root namespace for fundamental types in the .NET Framework. This namespace also contains classes (for example, `System.String` and `System.Array`) and second-level namespaces (for example, `System.Collections.Generic`). The `mscorlib` and `system` assemblies, which MATLAB loads at startup, contain many, but not all `System` namespaces. For example, to use classes in the `System.Xml` namespace, load the `system.xml` assembly using the `NET.addAssembly` command. Refer to the Microsoft .NET Framework Class Library Reference to learn what assembly to use for a specific namespace.

Reference Type Versus Value Type

Objects created from .NET classes (for example, the `System.Reflection.Assembly` class) appear in MATLAB as *reference types*, or handle objects. Objects created from .NET structures (for example, the `System.DateTime` structure) appear as *value types*. You use the same MATLAB syntax to create and access members of classes and structures.

However, handle objects are different from value objects. When you copy a handle object, only the handle is copied and both the old and new handles refer to the same data. When you copy a value object, the object's data is also copied and the new object is independent of changes to the original object. For more information about these differences, see “Copying Objects”.

Do not confuse an object created from a .NET structure with a MATLAB structure array (see “Structures”). You cannot pass a structure array to a .NET method.

Simplifying .NET Class Names

In a MATLAB command, you can refer to any class by its fully qualified name, which includes its package name. A fully qualified name might be long, making commands and functions, such as constructors, cumbersome to edit and to read. You can refer to classes by the class name alone (without a package name) if you first import the fully qualified name into MATLAB. The `import` function adds all classes that you import to a list called the import list. You can see what classes are on that list by typing `import`, without any arguments.

For example, to eliminate the need to type `System.` before every command in the “Access a Simple .NET Class” on page 8-73 example, type:

```
import System.*  
import System.DateTime.*
```

To create the object, type:

```
dateObj = DateTime.Today;
```

To use a static method, type:

```
DaysInMonth(dateObj.Year, dateObj.Month)
```

Using import in MATLAB Functions

If you use the `import` command in a MATLAB function, you must add the corresponding .NET assembly before calling the function. For example, the following function `getPrinterInfo` calls methods in the `System.Drawing` namespace.

```
function ptr = getPrinterInfo
import System.Drawing.Printing.*;
ptr = PrinterSettings;
end
```

To call the function, type:

```
NET.addAssembly('System.Drawing');
printer = getPrinterInfo;
```

You cannot add the command `NET.addAssembly('System.Drawing')` to the `getPrinterInfo` function. MATLAB processes the `getPrinterInfo.m` code before executing the `NET.addAssembly` command. In that case, `PrinterSettings` is not fully-qualified and MATLAB does not recognize the name.

Likewise, the scope of the `import` command is limited to the `getPrinterInfo` function. At the command line, type:

```
ptr = PrinterSettings;
```

```
Undefined function or variable 'PrinterSettings'.
```

Loading .NET Assemblies into MATLAB

If MATLAB does not automatically load your assembly, use the `NET.addAssembly` function. The syntax is:

```
asmInfo = NET.addAssembly('assemblyName');
```

You need to know if the assembly is global or private, as explained in “What is an Assembly?” on page 8-8 Your vendor documentation has this information.

You cannot unload an assembly from MATLAB.

Handling Exceptions

MATLAB catches exceptions thrown by .NET and converts them into a `NET.NetException` object, which is derived from the `MException` class. The default display of `NetException` contains the `Message`, `Source` and `HelpLink` fields of the `System.Exception` class that caused the exception. For example:

```
try
    NET.addAssembly('C:\Work\invalidfile.dll')
catch e
    e.message
    if(isa(e,'NET.NetException'))
        e.ExceptionObject
    end
end
```

Working With Nested Classes

In MATLAB, you cannot directly instantiate a nested class but here is how to do it through reflection. The following C# code defines `InnerClass` nested in `OuterClass`:

```
namespace MyClassLibrary
{
    public class OuterClass
    {
        public class InnerClass
        {
            public String strmethod(String x)
            {
                return "from InnerClass " + x;
            }
        }
    }
}
```

If the `MyClassLibrary` assembly is in your `c:\work` folder, load the file:

```
a = NET.addAssembly('C:\Work\MyClassLibrary.dll');
```

a.Classes

```
ans =  
    'MyClassLibrary.OuterClass'  
    'MyClassLibrary.OuterClass+InnerClass'
```

To call strmethod, type:

```
t = a.AssemblyHandle.GetType('MyClassLibrary.OuterClass+InnerClass');  
obj = System.Activator.CreateInstance(t);  
strmethod(obj, 'hello')
```

```
ans =  
from InnerClass hello
```

Using a .NET Object

In this section...

“Creating a .NET Object” on page 8-14

“Building a .NET Application for MATLAB Examples” on page 8-14

“What Classes Are in a .NET Assembly?” on page 8-15

“Using the delete Function on a .NET Object” on page 8-15

Creating a .NET Object

You often need to create objects when working with .NET classes. An *object* is an instance of a particular class. Methods are functions that operate exclusively on objects of a class. Data types package together objects and methods so that the methods operate on objects of their own type. For more information about objects, see “MATLAB Objects”.

You construct .NET objects in the MATLAB workspace by calling the class constructor, which has the same name as the class. The syntax to create a .NET object `classObj` is:

```
classObj = namespace.ClassName(varargin)
```

where `varargin` is the list of constructor arguments to create an instance of the class specified by `ClassName` in the given namespace. For an example, see “Create .NET Object From Constructor” on page 8-74.

Building a .NET Application for MATLAB Examples

You can use C# code examples in MATLAB, such as the `NetDocCell` assembly provided in “Converting .NET Arrays to Cell Arrays” on page 8-28. Build an application using a C# development tool, like Microsoft Visual Studio and then load it into MATLAB using the `NET.addAssembly` function. The following are basic steps to do this; consult your development tool documentation for specific instructions.

- 1 From your development tool, open a new project and create a C# class library.

- 2 Copy the classes and other constructs from the C# files into your project.
- 3 Build the project as a DLL.
- 4 The name of this assembly is the namespace. Note the full path to the DLL file. Since it is a private assembly, you must use the full path to load it in MATLAB.
- 5 After you load the assembly, if you modify and rebuild it, you must restart MATLAB to access the new assembly. You cannot unload an assembly in MATLAB.

What Classes Are in a .NET Assembly?

The product documentation for your assembly contains information about its classes. However, you can use the `NET.addAssembly` command to read basic information about an assembly. For example, to view the class names for the private assembly `netdoc.NetSample`, type:

```
dllPath = fullfile('c:', 'work', 'NetSample.dll');
sampleInfo = NET.addAssembly(dllPath);
sampleInfo.Classes
```

```
ans =
    'netdoc.SampleMethodSignature'
    'netdoc.SampleMethods'
```

If your assembly has hundreds of entries, you can consult the product documentation, or open a window to an online document, such as the `System` namespace reference page on the Microsoft Developer Network. For information about using this documentation, see “To Learn More About the .NET Framework” on page 8-6. For example, to find the number of classes `nclasses` in `mscorlib`, type:

```
asm = NET.addAssembly('mscorlib');
[nclasses, x] = size(asm.Classes);
```

Using the delete Function on a .NET Object

Objects created from .NET classes appear in MATLAB as reference types, or handle objects. Calling the `delete` function on a .NET handle releases all

references to that .NET object from MATLAB, but does not invoke any .NET finalizers. The .NET Framework manages garbage collection.

For more information about managing handle objects, see “Destroying Objects”.

Using .NET Properties

In this section...

“How MATLAB Represents .NET Properties” on page 8-17

“How MATLAB Maps C# Property and Field Access Modifiers” on page 8-18

How MATLAB Represents .NET Properties

To view property names, use the `properties` function.

To get and set the value of a class property, use the MATLAB dot notation:

```
x = ClassName.PropertyName;  
ClassName.PropertyName = y;
```

The following example gets the value of a property (the current day of the month):

```
obj = System.DateTime.Now;  
d = obj.Day;
```

The following example sets the value of a property (the Volume for a `SpeechSynthesizer` object):

```
NET.addAssembly('System.Speech');  
obj = System.Speech.Synthesis.SpeechSynthesizer;  
obj.Volume = 50;  
Speak(obj,'You can use .NET Libraries in MATLAB');
```

To set a static property, you must call the `NET.setStaticProperty` function. For an example, see “Set Static .NET Properties” on page 8-91.

MATLAB represents public .NET fields as properties.

MATLAB represents .NET properties that take an argument as methods. For more information, see “Call .NET Properties That Take an Argument” on page 8-22.

How MATLAB Maps C# Property and Field Access Modifiers

MATLAB maps C# keywords to MATLAB property attributes, as shown in the following table.

C# Property Keyword	MATLAB Attribute
public, static	Access = public
protected, private, internal	Not visible to MATLAB
get, set	Access = public
Get	GetAccess = public, SetAccess = private
Set	SetAccess = public, GetAccess = private

MATLAB maps C# keywords to MATLAB field attributes, as shown in the following table.

C# Field Keyword	MATLAB Mapping
public	Supported
protected, private, internal, protected internal	Not visible to MATLAB

For more information about MATLAB properties, see “Property Attributes”.

Using .NET Methods in MATLAB

In this section...

- “Calling .NET Methods” on page 8-19
- “Calling .NET Generic Methods” on page 8-21
- “Calling .NET Methods with Optional Arguments” on page 8-21
- “Calling .NET Extension Methods” on page 8-22
- “Call .NET Properties That Take an Argument” on page 8-22
- “How MATLAB Represents .NET Operators” on page 8-23
- “Limitations to Support of .NET Methods” on page 8-24

Calling .NET Methods

The following topics describe using .NET methods in MATLAB.

- “Getting Method Information” on page 8-19
- “C# Method Access Modifiers” on page 8-20
- “VB.NET Method Access Modifiers” on page 8-20
- “Reading Method Signatures” on page 8-20

Getting Method Information

Use the following MATLAB functions to view the methods of a class. You can use these functions without creating an instance of the class. These functions do not list generic methods; use your product documentation to get information on generic methods.

- `methods` — View method names
- `methods` with `'-full'` option — View method names with argument list
- `methodsview` — Graphical representation of method list

You might find the `methodsview` window easier to use as a reference guide because you do not need to scroll through the Command Window

to find information. For example, open a methodsview window for the System.String class:

```
methodsview('System.String')
```

C# Method Access Modifiers

MATLAB maps C# keywords to MATLAB method access attributes, as shown in the following table.

C# Method Keyword	MATLAB Attribute
ref	RHS, LHS
out	LHS
params	Array of particular type
protected, private, internal, protected internal	Not visible to MATLAB

VB.NET Method Access Modifiers

MATLAB maps VB.NET keywords to MATLAB method access attributes, as shown in the following table.

VB.NET Method Keyword	MATLAB Attribute
ByRef	LHS, RHS
ByVal	RHS
Optional	Mandatory

Reading Method Signatures

MATLAB uses the following rules to populate method signatures.

- obj is the output from the constructor.
- this is the object argument.
- RetVal is the return type of a method.
- All other arguments use the .NET metadata.

MATLAB uses the following rules to select a method signature.

- Number of inputs
- Input type
- Number of outputs

Calling .NET Generic Methods

Use the `NET.invokeGenericMethod` function to call a generic method.

Calling .NET Methods with Optional Arguments

MATLAB displays optional arguments in a method signature using the `optional<T>` syntax, where `T` is the specific type. This feature is available in .NET Framework Version 4.0 and above.

To use a default method argument, pass an instance of `System.Reflection.Missing.Value`.

Skipping Optional Arguments

If the method is not overloaded, you are not required to fill in all optional values at the end of a parameter list. For examples, see “Skip Optional Arguments” on page 8-100.

Determining Which Overloaded Method Is Invoked

If a .NET class has overloaded methods with optional arguments, MATLAB picks the method matching the exact number of input arguments.

If the optional arguments of the methods are different by type, number, or dimension, MATLAB first compares the types of the mandatory arguments. If the types of the mandatory arguments are different, MATLAB chooses the first overloaded method defined in the class. If the types of the mandatory arguments are the same, you must specify enough optional arguments so that there is only one possible matching .NET method. Otherwise, MATLAB throws an error. For examples, see “Call Overloaded Methods” on page 8-101.

Support for ByRef Attribute in VB.NET

The rules for optional ByRef arguments are the same as for other method arguments, as described in “VB.NET Method Access Modifiers” on page 8-20. ByRef arguments on the RHS appear as optional and behave like any other optional argument.

Calling .NET Extension Methods

Unlike C# applications, MATLAB handles an extension method as a static method of the class that defines the method. Refer to your product documentation for the namespace and class name you need to call such methods.

For information about extension methods, see the MSDN article at [http://msdn.microsoft.com/en-us/library/bb383977\(v=VS.90\).aspx](http://msdn.microsoft.com/en-us/library/bb383977(v=VS.90).aspx).

Call .NET Properties That Take an Argument

MATLAB represents a property that takes an argument as a method. For example, the `System.String` class has two properties, `Chars` and `Length`. The `Chars` property gets the character at a specified character position in the `System.String` object. For example:

```
str = System.String('my new string');  
methods(str)
```

Display of System.String Methods

Methods for class `System.String`:

<code>Chars</code>	<code>Normalize</code>	<code>TrimStart</code>
<code>Clone</code>	<code>PadLeft</code>	<code>addlistener</code>
<code>CompareTo</code>	<code>PadRight</code>	<code>char</code>
<code>Contains</code>	<code>Remove</code>	<code>delete</code>
<code>CopyTo</code>	<code>Replace</code>	<code>eq</code>
<code>EndsWith</code>	<code>Split</code>	<code>findobj</code>
<code>Equals</code>	<code>StartsWith</code>	<code>findprop</code>
<code>GetEnumerator</code>	<code>String</code>	<code>ge</code>
<code>GetHashCode</code>	<code>Substring</code>	<code>gt</code>
<code>GetType</code>	<code>ToCharArray</code>	<code>isvalid</code>

```

GetTypeCode      ToLower          le
IndexOf          ToLowerInvariant lt
IndexOfAny       ToString         ne
Insert           ToUpper          notify
IsNormalized     ToUpperInvariant
LastIndexOf      Trim
LastIndexOfAny  TrimEnd

```

Static methods:

```

Compare          Intern            op_Equality
CompareOrdinal  IsInterned       op_Inequality
Concat           IsNullOrEmpty
Copy            IsNullOrWhiteSpace
Format          Join

```

Notice that MATLAB displays the Chars property as a method.

The Chars method has the following signature.

Return Type	Name	Arguments
char scalar RetVal	Chars	(System.String this, int32 scalar index)

To see the first character, type:

```
Chars(str,0)
```

```
ans =
m
```

How MATLAB Represents .NET Operators

MATLAB supports overloaded operators, such as the C# operator symbols + and *, as shown in the following table. MATLAB implements all other overloaded operators, such as % and +=, by their static method names, op_Modulus and op_AdditionAssignment. For a complete list of operator symbols and the corresponding operator names, see [http://msdn.microsoft.com/en-us/library/2sk3x8a7\(VS.71\).aspx](http://msdn.microsoft.com/en-us/library/2sk3x8a7(VS.71).aspx) on the Microsoft Developer Network Web site.

C++ operator symbol	.NET operator	MATLAB methods
+ (binary)	op_Addition	plus, +
- (binary)	op_Subtraction	minus, -
* (binary)	op_Multiply	mtimes, *
/	op_Division	mrdivide, /
&&	op_LogicalAnd	and, &
	op_LogicalOr	or,
==	op_Equality	eq, ==
>	op_GreaterThan	gt, >
<	op_LessThan	lt, <
!=	op_Inequality	ne, ~=
>=	op_GreaterThanOrEqual	ge, >=
<=	op_LessThanOrEqual	le, <=
- (unary)	op_UnaryNegation	uminus, -a
+ (unary)	op_UnaryPlus	uplus, +a

Limitations to Support of .NET Methods

The methods and methodsview functions do not list generic methods.

Overloading MATLAB Functions

If your application implements a method with the same name as a MATLAB function, the method must have the same signature as the MATLAB function. Otherwise, MATLAB throws an error. For information about how MATLAB handles overloaded functions, see the following topics:

- “Overloading Functions for Your Class”
- “Methods That Modify Default Behavior”

Working with .NET Events in MATLAB

In this section...

“Use .NET Events in MATLAB” on page 8-25

“Limitations to Support of .NET Events” on page 8-26

Use .NET Events in MATLAB

Use the `addlistener` function to handle events from .NET objects.

For example, you can monitor changes to files using the `System.IO.FileSystemWatcher` class in the `System` assembly. Create the following event handler, `eventhandlerChanged.m`:

```
function eventhandlerChanged(source,arg)
disp('TXT file changed')
end
```

Create a `FileSystemWatcher` object `fileObj` and watch the `Changed` event for files with a `.txt` extension in the folder `C:\work\temp`.

```
fileObj = System.IO.FileSystemWatcher('c:\work\temp');
fileObj.Filter = '*.txt';
fileObj.EnableRaisingEvents = true;
addlistener(fileObj,'Changed',@eventhandlerChanged);
```

If you modify and save a `.txt` file in the `C:\work\temp` folder, MATLAB displays:

```
TXT file changed
```

The `FileSystemWatcher` documentation says that a simple file operation can raise multiple events.

To turn off the event handler, type:

```
fileObj.EnableRaisingEvents = false;
```

Limitations to Support of .NET Events

MATLAB Support of Standard Signature of an Event Handler Delegate

An event handler in C# is a delegate with the following signature:

```
public delegate void MyEventHandler(object sender, MyEventArgs e)
```

The argument `sender` specifies the object that fired the event. The argument `e` holds data that can be used in the event handler. The class `MyEventArgs` is derived from the .NET Framework class `EventArgs`. MATLAB only handles events with this standard signature.

Using Arrays with .NET Applications

In this section...

“Passing MATLAB Arrays to .NET” on page 8-27

“Accessing .NET Array Elements in MATLAB” on page 8-27

“Converting .NET Arrays to Cell Arrays” on page 8-28

“Converting .NET Jagged Arrays to MATLAB Arrays” on page 8-30

“Limitations to Support of .NET Arrays” on page 8-30

Passing MATLAB Arrays to .NET

MATLAB automatically converts arrays to .NET types, as described in the MATLAB® Primitive Type Conversion Table on page 8-110. To pass an array of strings, create a cell array. For all other types, use the MATLAB `NET.createArray` function.

Accessing .NET Array Elements in MATLAB

You access elements of a .NET array with subscripts, just like with MATLAB arrays.

You cannot refer to the elements of a multidimensional .NET array with a single subscript (linear indexing) like you can in MATLAB, as described in “Matrix Indexing”. You must specify the index for each dimension of the .NET array.

You can only use scalar indexing to access elements of a .NET array. The colon operator, described in “Generating a Numeric Sequence”, is not supported.

Using the Get and Set Instance Functions

Alternatively, you can access elements of a .NET array using the `Set` and `Get` instance functions. When using `Set` or `Get` you must use C# array indexing, which is zero-based.

For example, create two `System.String` arrays, using the `Set` function and direct assignment:

```
d1 = NET.createArray('System.String',3);  
d1.Set(0, 'one');  
d1.Set(1, 'two');  
d1.Set(2, 'three');
```

```
d2 = NET.createArray('System.String',3);  
d2(1) = 'one';  
d2(2) = 'two';  
d2(3) = 'zero';
```

To compare the values of the first elements in each array, type:

```
System.String.Compare(d1(1),d2.Get(0))
```

MATLAB displays 0, meaning the strings are equal.

Converting .NET Arrays to Cell Arrays

You can convert .NET `System.String` and `System.Object` arrays to MATLAB cell arrays using the `cell` function. Elements of the cell array are of the MATLAB type closest to the .NET type, described in “.NET Type to MATLAB Type Mapping” on page 8-117.

For example, create a cell array of names of the folders in your `c:\` folder, using the .NET Framework `System.IO.Directory` class:

```
myList = cell(System.IO.Directory.GetDirectories('c:\'));
```

Converting Nested System.Object Arrays

The conversion is not recursive for a `System.Object` array contained within a `System.Object` array. You must use the `cell` function to convert each `System.Object` array.

To run this example, build the `NetDocCell` assembly using the directions in “Building a .NET Application for MATLAB Examples” on page 8-14. The source code is here:

C# NetDocCell Source File

```
using System;
```

```

/*
 * C# Assembly used in MATLAB .NET documentaion.
 * Method getNewData is used to demonstrate
 * how MATLAB handles a System.Object
 * that includes another System.Object.
 */
namespace NetDocCell
{
    public class MyGraph
    {
        public Object[] getNewData()
        /*
         * Create a System.Object array to use in MATLAB examples.
         * Returns containerArr System.Object array containing:
         * fLabel System.String object
         * plotData System.Object array containing:
         *     xLabel System.String object
         *     doubleArr System.Double array
         */
        {
            String fLabel = "Figure Showing New Graph Data";
            Double[] doubleArr = {
18, 32, 3.133, 44, -9.9, -13, 33.03 };
            String xLabel = "X-Axis Label";
            Object[] plotData = { xLabel, doubleArr };
            Object[] containerArr = { fLabel, plotData };
            return containerArr;
        }
    }
}

```

Load the assembly and create a cell array, m1Data:

```

dllPath = fullfile('c:', 'work', 'NetDocCell.dll');
NET.addAssembly(dllPath);
obj = NetDocCell.MyGraph;
m1Data = cell(obj.getNewData)

```

The cell array contains elements of the following type:

```
mldata =  
    [1x1 System.String]    [1x1 System.Object[]]
```

To access the contents of the `System.Object` array, create another cell array `mldata`:

```
mldata = cell(mldata{2})
```

This cell array contains elements of the following type:

```
mldata =  
    [1x1 System.String]    [1x1 System.Double[]]
```

For another example, see “Pass Cell Arrays of .NET Data” on page 8-104.

Converting .NET Jagged Arrays to MATLAB Arrays

You must convert a .NET jagged array before using it in a MATLAB command.

- If the shape of the array is rectangular, use the corresponding MATLAB numeric function.
- If the array is not rectangular, use the `cell` function.

If the jagged array is multidimensional, you must individually convert the arrays in each dimension.

Limitations to Support of .NET Arrays

MATLAB does not support:

- Arrays which specify a lower bound
- Concatenating .NET objects into an array
- The `end` function as the last index in a .NET array
- Array indices of complex values
- Autoconversion of `char` or `cell` arrays to jagged array arguments.
- Autoconversion of MATLAB arrays to multidimensional jagged array arguments.

Pass Jagged Arrays

In this section...

“Create System.Double .NET Jagged Array” on page 8-31

“Call .NET Method with System.String Jagged Array Arguments” on page 8-32

“Call .NET Method with Multidimensional Jagged Array Arguments” on page 8-33

Create System.Double .NET Jagged Array

This example shows how to create a .NET jagged array of System.Double using the NET.createArray function.

Create a 3 element array.

```
jArr = NET.createArray('System.Double[]',3)
```

```
jArr =
```

```
System.Double[][] handle
Package: System

Properties:
    Length: 3
    LongLength: 3
    Rank: 1
    SyncRoot: [1x1 System.Double[][]]
    IsReadOnly: 0
    IsFixedSize: 1
    IsSynchronized: 0
```

```
Methods, Events, Superclasses
```

You can pass jArr to any .NET method with an input or output argument of type System.Double[][].

Call .NET Method with System.String Jagged Array Arguments

This example shows how to create an array of MATLAB strings to pass to a method, `MethodStringArr`, with a `System.String[][]` input argument.

The following is the MATLAB function signature for `MethodStringArr`.

Return Type	Name	Arguments
<code>System.String[][]</code> <code>RetVal</code>	<code>MethodStringArr</code>	(<code>NetPackage.StringClass</code> this, <code>System.String[][]</code> arr)

The MATLAB strings you want to pass to the method are:

```
str1 = {'this', 'is'};
str2 = 'jagged';
```

Create a variable, `netArr`, of `System.String` arrays, which contains two arrays. Using the `NET.createArray`, the `typeName` for this array is `System.String[]`, and the dimension is 2.

```
netArr = NET.createArray('System.String[]',2);
```

The arrays contain empty strings.

Create `System.String` arrays to correspond to the MATLAB strings, `str1` and `str2`.

```
netArr(1) = NET.createArray('System.String',2);
netArr(2) = NET.createArray('System.String',1);
```

Assign `str1` and `str2` to `netArr`.

```
netArr(1) = str1;
netArr(2,1) = str2;
```

Because `str2` is a scalar and `netArr(2)` expects an array, you must assign `str2` to the specific element `netArr(2,1)`.

Now you can pass `netArr` to the `MethodStringArr` method.

```
class(netArr)

ans =
System.String[][]
```

Call .NET Method with Multidimensional Jagged Array Arguments

This example shows how to create a MATLAB array to pass to a method, `MethodMultiDArr`, with a multidimensional jagged array input argument of `System.Double` type.

The following is the MATLAB function signature for `MethodMultiDArr`. The input is a multidimensional jagged array that contains single dimensional elements.

Return Type	Name	Arguments
<code>System.Double[][]</code> , <code>RetVal</code>	<code>MethodMultiDArr</code>	<code>(NetPackage.NumericClass this, System.Double[][] arr)</code>

Create a 2-by-3 array with `typeName` of `System.Double[]`.

```
arr = NET.createArray('System.Double[]',2,3);
```

The elements are empty arrays.

The MATLAB arrays you want to pass to the method are:

```
A1 = [1 2 3];
A2 = [5 6 7 8];
```

MATLAB automatically converts a numeric array to the equivalent .NET type.

```
arr(1,1) = A1;
arr(1,2) = A2;
```

Array `arr` is a `System.Double[,]` jagged array.

```
arr
```

```
arr =
```

```
System.Double[,] handle  
Package: System
```

```
Properties:
```

```
    Length: 6  
    LongLength: 6  
    Rank: 2  
    SyncRoot: [1x1 System.Double[,] ]  
    IsReadOnly: 0  
    IsFixedSize: 1  
    IsSynchronized: 0
```

```
Methods, Events, Superclasses
```

Now you can pass `arr` to the `MethodMultiDArr` method.

.NET Delegates in MATLAB

In this section...

- “.NET Delegates” on page 8-35
- “Call .NET Delegates in MATLAB” on page 8-36
- “Create Delegates from .NET Object Methods” on page 8-37
- “Create Delegate Instances Bound to .NET Methods” on page 8-38
- “Call Delegates With out and ref Type Arguments” on page 8-39
- “Combine and Remove .NET Delegates” on page 8-40
- “Calling .NET Methods Asynchronously” on page 8-41
- “Limitations to Support of .NET Delegates” on page 8-45

.NET Delegates

In the .NET Framework, a *delegate* is a type that defines a method signature. It lets you pass a function as a parameter. The use of delegates enables .NET applications to make calls into MATLAB callback functions or class instance methods. For the rules MATLAB uses to define the signature of a callback function or class method, see “Reading Method Signatures” on page 8-20 in Using a .NET Object. For a complete description of delegates and when to use them, consult an outside resource, such as the Microsoft Developer Network.

There are three steps to using delegates:

- Declaration — Your .NET application contains the declaration. You cannot declare a delegate in the MATLAB language.
- Instantiation — In MATLAB, create an instance of the delegate and associate it with a specific MATLAB function or .NET object method.
- Invocation — Call the function with specified input and output arguments. Use the delegate name in place of the function name.

Call .NET Delegates in MATLAB

This example shows you how to use a delegate in MATLAB. It creates a delegate using a MATLAB function (`char`). For another example, see “Create Delegates from .NET Object Methods” on page 8-37.

This example consists of the following tasks:

- “Declare a Delegate in a C# Assembly” on page 8-36
- “Load the Assembly Containing the Delegate into MATLAB” on page 8-36
- “Select a MATLAB Function” on page 8-36
- “Create an Instance of the Delegate in MATLAB” on page 8-37
- “Invoke the Delegate Instance in MATLAB” on page 8-37

Declare a Delegate in a C# Assembly

The C# example `NetDocDelegate.cs`, in the `matlabroot/extern/examples/NET/NetSample` folder, defines delegates used in the following examples. To see the code, open the file in MATLAB Editor. To run the examples, build the `NetDocDelegate` assembly as described in “Building a .NET Application for MATLAB Examples” on page 8-14.

Load the Assembly Containing the Delegate into MATLAB

If the `NetDocDelegate` assembly is in your `c:\work` folder, load the file with the command:

```
dllPath = fullfile('c:', 'work', 'NetDocDelegate.dll');  
NET.addAssembly(dllPath);
```

Select a MATLAB Function

The `delInteger` delegate encapsulates any method that takes an integer input and returns a string. The MATLAB `char` function, which converts a nonnegative integer into a character array (string), has a signature that matches the `delInteger` delegate. For example, the following command displays the `!` character:

```
char(33)
```

Create an Instance of the Delegate in MATLAB

To create an instance of the `delInteger` delegate, pass the function handle of the `char` function:

```
myFunction = NetDocDelegate.delInteger(@char);
```

Invoke the Delegate Instance in MATLAB

Use `myFunction` the same as you would `char`. For example, the following command displays the `!` character:

```
myFunction(33)
```

Create Delegates from .NET Object Methods

The following C# class defines the methods `AddEggs` and `AddFlour`, which have signatures matching the `delInteger` delegate:

C# Recipe Source File

```
using System;
namespace Recipe
{
    public class MyClass
    {
        public string AddEggs(double n)
        {
            return "Add " + n + " eggs";
        }

        public string AddFlour(double n)
        {
            return "Add " + n + " cups flour";
        }
    }
}
```

Build the `Recipe` assembly, and then load it and create a delegate `myFunc` using `AddEggs` as the callback:

```
NET.addAssembly(dllPath);
NET.addAssembly('c:\work\Recipe.dll');
```

```
obj = Recipe.MyClass;
myFunc = NetDocDelegate.delInteger(@obj.AddEggs);
myFunc(2)

ans =
Add 2 eggs
```

Create Delegate Instances Bound to .NET Methods

For a C# delegate defined as:

```
namespace MyNamespace
{
    public delegate void MyDelegate();
}
```

MATLAB creates the following constructor signature.

Return Type	Name	Arguments
MyNamespace.MyDelegate obj	MyDelegate	(target, string methodName)

The argument target is one of the following:

- An instance of the invocation target object when binding to the instance method
- A string with fully qualified .NET class name when binding to a static method

methodName is a string specifying the callback method name.

Example — Create a Delegate Instance Associated with a .NET Object Instance Method

For the following C# delegate and class definition:

```
namespace MyNamespace
{
    public delegate void MyDelegate();
```

```

public class MyClass
{
    public void MyMethod(){}
}
}

```

To instantiate the delegate in MATLAB, type:

```

targetObj = MyNamespace.MyClass();
delegateObj = MyNamespace.MyDelegate(targetObj, 'MyMethod');

```

Example — Create a Delegate Instance Associated with a Static .NET Method

For the following C# delegate and class definition:

```

namespace MyNamespace
{
    public delegate void MyDelegate();

    public class MyClass
    {
        public static void MyStaticMethod(){}
    }
}

```

To instantiate the delegate in MATLAB, type:

```

delegateObj=MyNamespace.MyDelegate(...
    'MyNamespace.MyClass', 'MyStaticMethod');

```

Call Delegates With out and ref Type Arguments

The MATLAB rules for mapping out and ref types for delegates are the same as for methods. See “C# Method Access Modifiers” on page 8-20.

For example, the following C# statement declares a delegate with a ref argument:

```

public delegate void delref(ref Double refArg);

```

The signature for an equivalent MATLAB delegate function maps `refArg` as both RHS and LHS arguments:

```
function refArg = myFunc(refArg)
```

The following C# statement declares a delegate with an out argument:

```
public delegate void delout(  
    Single argIn,  
    out Single argOut);
```

The signature for an equivalent MATLAB delegate function maps `argOut` as an LHS argument:

```
function argOut = myFunc(argIn)
```

Combine and Remove .NET Delegates

MATLAB provides the instance method `Combine`, that lets you combine a series of delegates into a single delegate. The `Remove` and `RemoveAll` methods delete individual delegates. For more information, refer to the .NET Framework Class Library, as described in “To Learn More About the .NET Framework” on page 8-6.

For example, create the following MATLAB functions to use with the `NetDocDelegate.delInteger` delegate:

```
function out = action1(n)  
out = 'Add flour';  
disp(out);  
end
```

```
function out = action2(n)  
out = 'Add eggs';  
disp(out);  
end
```

Create delegates `step1` and `step2`:

```
step1 = NetDocDelegate.delInteger(@action1);  
step2 = NetDocDelegate.delInteger(@action2);
```

To combine into a new delegate, `mixItems`, type:

```
mixItems = step1.Combine(step2);
```

Or, type:

```
mixItems = step1.Combine(@action2);
```

Invoke `mixItems`:

```
result = mixItems(1);
```

In this case, the function `action2` follows `action1`:

```
Add flour  
Add eggs
```

The value of `result` is the output from the final delegate (`step2`).

```
result =  
Add eggs
```

You also can use the `System.Delegate` class static methods, `Combine`, `Remove` and `RemoveAll`.

To remove a `step1` from `mixItems`, type:

```
step3 = mixItems.Remove(step1);
```

Calling .NET Methods Asynchronously

It is possible to call a synchronous method asynchronously in MATLAB. With some modifications, you can use the Microsoft `BeginInvoke` and `EndInvoke` methods. For more information, refer to the MSDN article “Calling Synchronous Methods Asynchronously” at <http://msdn.microsoft>.

You can use delegates to call a synchronous method asynchronously by using the `BeginInvoke` and `EndInvoke` methods. If the thread that initiates the asynchronous call does not need to be the thread that processes the results, you can execute a callback method when the call completes. For information about using a callback method, see “Calling a Method Asynchronously Using a Callback When an Asynchronous Call Finishes” on page 8-42.

Note MATLAB is a single-threaded application. Therefore, handling asynchronous calls in the MATLAB environment might result in deadlocks.

- “Calling a Method Asynchronously Using a Callback When an Asynchronous Call Finishes” on page 8-42
- “Calling a Method Asynchronously Without a Callback” on page 8-43
- “Using EndInvoke With out and ref Type Arguments” on page 8-45
- “Using Polling to Detect When Asynchronous Call Finishes” on page 8-45

Calling a Method Asynchronously Using a Callback When an Asynchronous Call Finishes

You can execute a callback method when an asynchronous call completes. A callback method executes on a different thread than the thread that processes the results of the asynchronous call.

The following is an overview of the procedure. If you do not use a callback function, follow the procedure in “Calling a Method Asynchronously Without a Callback” on page 8-43.

- Select or create a MATLAB function to execute asynchronously.
- Select or create a C# delegate and associate it with the MATLAB function.
- Create a MATLAB callback function with a `System.AsyncCallback Delegate` delegate signature. The signature, shown at the MSDN Web site, is:

```
public delegate void AsyncCallback(IAsyncResult ar)
```

- 1** Using MATLAB code, initiate the asynchronous call using the `BeginInvoke` method, specifying the callback delegate and, if required, object parameters.
- 2** Continue executing commands in MATLAB.
- 3** When the asynchronous function completes, MATLAB calls the callback function, which executes the `EndInvoke` method to retrieve the results.

Callback Example. In this example, create the following MATLAB function to execute asynchronously:

```
function X = DivideFunction(A, B)
if B ~= 0
    X = A / B;
else
    errid = 'MyID:DivideFunction:DivisionByZero';
    error(errid, 'Division by 0 not allowed.');
```

Create the following MATLAB function, which will execute as the callback when the asynchronous method invocation completes. This function displays the result value of the EndInvoke method.

```
function myCallback(asyncRes)
result = asyncRes.AsyncDelegate.EndInvoke(asyncRes);
disp(result);
end
```

Use the del2Integer delegate, defined in the NetDocDelegate assembly:

```
public delegate Int32 del2Integer(Int32 arg1, Int32 arg2);
```

Run the example:

```
% Create the delegate
divDel = NetDocDelegate.del2Integer(@DivideFunction);
A=10;
B=5;
% Initiate the asynchronous call.
asyncRes = divDel.BeginInvoke(A,B,@myCallback,[]);
```

MATLAB displays the result: 2

Calling a Method Asynchronously Without a Callback

The following is an overview of the procedure. If you want to use a callback function, follow the procedure in “Calling a Method Asynchronously Using a Callback When an Asynchronous Call Finishes” on page 8-42.

- Select or create a MATLAB function to execute asynchronously.
 - Select or create a C# delegate and associate it with the MATLAB function.
- 1** In MATLAB, initiate the asynchronous call using the `BeginInvoke` method.
 - 2** Continue executing commands in MATLAB.
 - 3** Poll for asynchronous call completion using the MATLAB `pause` function.
 - 4** When the asynchronous function completes, call the `EndInvoke` method to retrieve the results.

Example Without Callback. In this example, create the following MATLAB function, `myFunction`:

```
% MATLAB function to execute asynchronously
function res = myFunction(strValue)
res = strValue;
end
```

Use the `delString` delegate, defined in the `NetDocDelegate` assembly:

```
public delegate string delString(string message);
```

In MATLAB, create the delegate, `myDelegate`, define the input values, and start the asynchronous call:

```
myDelegate = NetDocDelegate.delString(@myFunction);
A='Hello';
asyncRes = myDelegate.BeginInvoke(A, [], []);
```

The `BeginInvoke` method returns the object, `asyncRes`, which you use to monitor the progress of the asynchronous call. Poll for results, using the MATLAB `pause` function to let MATLAB process the events:

```
while asyncRes.IsCompleted ~= true
    pause(0.01);
end
```

Retrieve and display the results of the asynchronous call:

```
result = myDelegate.EndInvoke(asyncRes);  
disp(result)
```

```
Hello
```

Using EndInvoke With out and ref Type Arguments

The MATLAB delegate signature for `EndInvoke` follows special mapping rules if your delegate has `out` or `ref` type arguments. For information about the mapping, see “Call Delegates With `out` and `ref` Type Arguments” on page 8-39. For examples, see the `EndInvoke` reference page.

Using Polling to Detect When Asynchronous Call Finishes

For MATLAB to process the event that executes the delegate’s callback on the main thread, you must call the MATLAB `pause` (or a similar) function.

Limitations to Support of .NET Delegates

MATLAB does not support associating a delegate instance with a generic .NET method.

When calling a method asynchronously, use the technique described in “Calling a Method Asynchronously Without a Callback” on page 8-43. Be aware that:

- MATLAB is a single-threaded application. Therefore, handling asynchronous calls in the MATLAB environment might result in deadlocks.
- For the technique described in the MSDN topic, MATLAB does not support the use of the `WaitOne()` method overload with no arguments.
- You cannot call `EndInvoke` to wait for the asynchronous call to complete.

.NET Enumerations in MATLAB

In this section...

- “Overview of .NET Enumerations” on page 8-46
- “Default Methods for an Enumeration” on page 8-47
- “Underlying Values” on page 8-48
- “Using the NetDocEnum Example Assembly” on page 8-49
- “Work with Members of a .NET Enumeration” on page 8-49
- “Refer to a .NET Enumeration Member” on page 8-51
- “Display .NET Enumeration Members as Character Strings” on page 8-52
- “Convert .NET Enumeration Values to Type Double” on page 8-52
- “Iterate Through a .NET Enumeration” on page 8-52
- “Use .NET Enumerations to Test for Conditions” on page 8-54
- “Use Bit Flags with .NET Enumerations” on page 8-56
- “Read Special System Folder Path” on page 8-59
- “Limitations to Support of .NET Enumerations” on page 8-60

Overview of .NET Enumerations

MATLAB allows you to work with *.NET enumerations* using features of the MATLAB enumeration class and some features unique to the .NET Framework.

Terms you should know:

- Enumeration — In MATLAB, a class having a finite set of named instances.
- Enumeration member — Named instance of an enumeration class.
- Underlying value — Numeric value associated with an enumeration member.

Enumerations contain the following information:

- Members
- Methods
- Underlying Values

In this topic, the term *enumeration* refers to a .NET enumeration.

Note The MATLAB language supports user-defined enumeration classes. If you are using enumerations defined in MATLAB, refer to the topics under Enumerations.

Default Methods for an Enumeration

By default, MATLAB provides the following methods for a .NET enumeration:

- Relational operators — `eq`, `ne`, `ge`, `gt`, `le`, and `lt`.
- Conversion methods — `char`, `double`, and a method to get the underlying value.
- Bit-wise methods — Only for enumerations with the `System.Flags` attribute.

For example, type:

```
methods('System.DayOfWeek')
```

```
Methods for class System.DayOfWeek:
```

```
CompareTo    eq  
DayOfWeek    ge  
Equals       gt  
GetHashCode  int32  
GetType      le  
GetTypeCode  lt  
ToString     ne  
char  
double
```

The method to get the underlying value is `int32`.

For examples using these methods, see “Example Using Relational Operations” on page 8-55, “Example Using Switch Statements” on page 8-54, and “Display .NET Enumeration Members as Character Strings” on page 8-52.

The `NetDocEnum.MyDays` enumeration, which has the `Flags` attribute, has the bit-wise methods. To list the methods, type:

```
methods('NetDocEnum.MyDays')
```

```
Methods for class NetDocEnum.MyDays:
```

```
CompareTo    char
Equals       double
GetHashCode  eq
GetType      ge
GetTypeCode  gt
MyDays       int32
ToString     le
bitand       lt
bitnot       ne
bitor
bitxor
```

For more information about bit-wise operators, see “Use Bit Flags with .NET Enumerations” on page 8-56.

Underlying Values

MATLAB supports enumerations of any numeric type.

To find the underlying type of an enumeration, use the `System.Enum` static method `GetUnderlyingType`. For example, the following C# statement in the `NetDocEnum` assembly declares the enumeration `Range`:

```
public enum Range : long {Max = 2147483648L,Min = 255L}
```

To display the underlying type:

```
maxValue = NetDocEnum.Range.Max;
System.Enum.GetUnderlyingType(maxValue.GetType()).FullName
```



```
ans =
System.Int64
```

Using the NetDocEnum Example Assembly

Some of the examples in this topic use the `System.DayOfWeek` enumeration, which is part of the .NET Framework. The C# example `NetDocEnum.cs`, in the `matlabroot/extern/examples/.NET/NetSample` folder, defines enumerations used in other examples. To see the code, open the file in MATLAB Editor. To run the examples, build the `NetDocEnum` assembly as described in “Building a .NET Application for MATLAB Examples” on page 8-14.

If the `NetDocEnum` assembly is in your `c:\work` folder, load the file:

```
dllPath = fullfile('c:', 'work', 'NetDocEnum.dll');
asm = NET.addAssembly(dllPath);
asm.Enums
```

```
ans =
    'NetDocEnum.MyDays'
    'NetDocEnum.Range'
```

Work with Members of a .NET Enumeration

To display the member names of an enumeration, use the MATLAB `enumeration` function. For example, to list the member names of the `System.DayOfWeek` enumeration, type:

```
enumeration('System.DayOfWeek')
```

```
Enumeration members for class 'System.DayOfWeek':
    Sunday
    Monday
    Tuesday
    Wednesday
    Thursday
    Friday
    Saturday
```

You cannot use the `enumeration` command to return arrays of .NET enumeration objects. You can read the names and values of the enumeration into arrays, using the `System.Enum` methods `GetNames`, `GetValues`, and

`GetType`. For more information about using these methods, see “Information About System.Enum Methods” on page 8-53.

For example, to create arrays `allNames` and `allValues` for the `System.DayOfWeek` enumeration, type:

```
myDay = System.DayOfWeek;  
allNames = System.Enum.GetNames(myDay.GetType);  
allValues = System.Enum.GetValues(myDay.GetType);
```

The class of the names array is `System.String`, while the class of the values array is the enumeration type `System.DayOfWeek`.

```
whos all*
```

Name	Size	Bytes	Class
<code>allNames</code>	1x1	112	<code>System.String[]</code>
<code>allValues</code>	1x1	112	<code>System.DayOfWeek[]</code>

Although the types are different, the information MATLAB displays is the same. For example, type:

```
allNames(1)
```

```
ans =  
Sunday
```

```
Type:
```

```
allValues(1)
```

```
ans =  
Sunday
```

For an example that uses arrays, see “Iterate Through a .NET Enumeration” on page 8-52. For information about using `System.String`, see “How MATLAB Handles `System.String`” on page 8-118.

Refer to a .NET Enumeration Member

- “Overview” on page 8-51
- “Using the Implicit Constructor” on page 8-51

Overview

You use an *enumeration member* in your code as an instance of an enumeration. To refer to an enumeration member, use the C# namespace, enumeration, and member names:

Namespace.EnumName.MemberName

For example, the `System` namespace in the .NET Framework class library has a `DayOfWeek` enumeration. The members of this enumeration are:

Enumeration members for class 'System.DayOfWeek':

```
Sunday
Monday
Tuesday
Wednesday
Thursday
Friday
Saturday
```

To create a variable with the value `Thursday`, type:

```
gameDay = System.DayOfWeek.Thursday;
whos
```

```
Name      Size Bytes Class
gameDay  1x1  104  System.DayOfWeek
```

Using the Implicit Constructor

The implicit constructor, *Namespace.EnumName*, creates a member with the default value of the underlying type. For example, the `NetDocEnum.Range` enumeration has the following members:

```
Enumeration members for class 'NetDocEnum.Range':
```

```
    Max  
    Min
```

```
Type:
```

```
x = NetDocEnum.Range  
whos x
```

```
x =  
0
```

Name	Size	Bytes	Class
x	1x1	104	NetDocEnum.Range

Display .NET Enumeration Members as Character Strings

Use the `char` method to get the descriptive name of an enumeration. For example, type:

```
gameDay = System.DayOfWeek.Thursday;  
['Next volleyball game is ',char(gameDay)]
```

```
ans =  
Next volleyball game is Thursday
```

Convert .NET Enumeration Values to Type Double

To convert a value to a MATLAB double, type:

```
gameDay = System.DayOfWeek.Thursday;  
myValue = double(gameDay)
```

```
myValue =  
4
```

Iterate Through a .NET Enumeration

- “Overview” on page 8-53

- “Information About System.Enum Methods” on page 8-53

Overview

To display all member names of the `System.DayOfWeek` enumeration, create a `System.String` array of names. Use the `Length` property of this array to find the number of members. For example:

```
myDay = System.DayOfWeek;
allNames = System.Enum.GetNames(myDay.GetType);
disp(['Members of ' class(myDay)]);
for idx = 1:allNames.Length
    disp(allNames(idx));
end
```

```
Members of System.DayOfWeek
Sunday
Monday
Tuesday
Wednesday
Thursday
Friday
Saturday
```

Information About System.Enum Methods

To create MATLAB arrays from an enumeration, use the static `System.Enum` methods `GetNames` and `GetValues`. The input argument for these methods is an enumeration type. Use the `GetType` method for the type of the current instance. To display the signatures for these methods, type:

```
methodsv('System.Enum')
```

Look at the following signatures:

Qualifiers	Return Type	Name	Arguments
	System.Type	GetType	(System.Enum this)
Static	System.String[]	GetNames	(System.Type enumType)
Static	System.Array	GetValues	(System.Type enumType)

To use `GetType`, create an instance of the enumeration. For example:

```
myEnum = System.DayOfWeek;
```

The `enumType` for `myEnum` is:

```
myEnumType = myEnum.GetType;
```

To create an array of names using the `GetNames` method, type:

```
allNames = System.Enum.GetNames(myEnumType);
```

Alternatively:

```
allNames = System.Enum.GetNames(myEnum.GetType);
```

Use .NET Enumerations to Test for Conditions

- “Example Using Switch Statements” on page 8-54
- “Example Using Relational Operations” on page 8-55

With relational operators, you can use enumeration members in `if` and `switch` statements and other functions that test for equality.

Example Using Switch Statements

The following `Reminder` function displays a message depending on the day of the week:

```
function Reminder(day)
% day = System.DayOfWeek enumeration value
```

```

% Add error checking here
switch(day)
    case System.DayOfWeek.Monday
        disp('Department meeting at 10:00');
    case System.DayOfWeek.Tuesday
        disp('Meeting Free Day!');
    case {System.DayOfWeek.Wednesday System.DayOfWeek.Friday}
        disp('Team meeting at 2:00');
    case System.DayOfWeek.Thursday
        disp('Volley ball night');
end
end

```

For example, type:

```

today = System.DayOfWeek.Wednesday;
Reminder(today)

```

```

ans =
Team meeting at 2:00

```

Example Using Relational Operations

Create the following function to display a message:

```

function VolleyballMessage(day)
% day = System.DayOfWeek enumeration value
if gt(day, System.DayOfWeek.Thursday)
    disp('See you next week at volleyball.')
else
    disp('See you Thursday!')
end
end

```

For a day before Thursday:

```

myDay = System.DayOfWeek.Monday;
VolleyballMessage(myDay)

```

```

See you Thursday!

```

For a day after Thursday:

```
myDay = System.DayOfWeek.Friday;  
VolleyballMessage(myDay)
```

See you next week at volleyball.

Use Bit Flags with .NET Enumerations

- “Overview” on page 8-56
- “Creating .NET Enumeration Bit Flags” on page 8-57
- “Removing a Flag from a Variable” on page 8-57
- “Replacing a Flag in a Variable” on page 8-58
- “Testing for Membership” on page 8-58

Overview

Many .NET languages support bit-wise operations on enumerations defined with the `System.Flags` attribute. The MATLAB language does not have equivalent operations, and, therefore, provides instance methods for performing bit-wise operations on an enumeration object. The bit-wise methods are `bitand`, `bitnot`, `bitor`, and `bitxor`.

An enumeration can define a *bit flag*. A bit flag lets you create instances of an enumeration to store combinations of values defined by the members. For example, files and folders have attributes, such as `Archive`, `Hidden` and `ReadOnly`. For a given file, perform an operation based on one or more of these attributes. With bit-wise operators, you can create and test for combinations.

To use bit-wise operators, the enumeration must have:

- The `Flags` attribute. In Framework Version 4, these enumerations also have the `HasFlag` method.
- Values that correspond to powers of 2.

Creating .NET Enumeration Bit Flags

Use the `NetDocEnum.MyDays` enumeration in the following examples. For more information, see “Using the `NetDocEnum` Example Assembly” on page 8-49.

Suppose you have the following scheduled activities:

- Monday — Department meeting at 10:00
- Wednesday and Friday — Team meeting at 2:00
- Thursday — Volley ball night

You can combine members of the `MyDays` enumeration to create MATLAB variables using the `bitor` method, which joins two members. For example, to create a variable `teamMtgs` of team meeting days, type:

```
teamMtgs = bitor(...
    NetDocEnum.MyDays.Friday,...
    NetDocEnum.MyDays.Wednesday);
```

Create a variable `allMtgs` of all days with meetings:

```
allMtgs = bitor(teamMtgs,...
    NetDocEnum.MyDays.Monday);
```

To see which days belong to each variable, type:

```
teamMtgs
allMtgs

teamMtgs =
Wednesday, Friday

allMtgs =
Monday, Wednesday, Friday
```

Removing a Flag from a Variable

Suppose your manager cancels the Wednesday meeting this week. Use the `bitxor` method to remove Wednesday from the `allMtgs` variable.

```
thisWeekMtgs = bitxor(allMtgs,NetDocEnum.MyDays.Wednesday)
```

```
thisWeekMtgs =  
Monday, Friday
```

Using a bit-wise method such as `bitxor` on `allMtgs` does not modify the value of `allMtgs`. This example creates a new variable, `thisWeekMtgs`, which contains the result of the operation.

Replacing a Flag in a Variable

Suppose you change the team meeting permanently from Wednesday to Thursday. Use `bitxor` to remove Wednesday, and use `bitor` to add Thursday. Since this is a permanent change, update the `teamMtgs` and `allMtgs` variables.

```
teamMtgs = bitor(...  
    (bitand(teamMtgs,...  
        bitnot(NetDocEnum.MyDays.Wednesday))),...  
    NetDocEnum.MyDays.Thursday);  
allMtgs = bitor(teamMtgs,...  
    NetDocEnum.MyDays.Monday);  
teamMtgs  
allMtgs
```

```
teamMtgs =  
Thursday, Friday
```

```
allMtgs =  
Monday, Thursday, Friday
```

Testing for Membership

Create the following `RemindMe` function:

```
function RemindMe(day)  
% day = NetDocEnum.MyDays enumeration  
teamMtgs = bitor(...  
    NetDocEnum.MyDays.Friday,...  
    NetDocEnum.MyDays.Wednesday);  
allMtgs = bitor(teamMtgs,...
```

```

        NetDocEnum.MyDays.Monday);

if eq(day,bitand(day,teamMtgs))
    disp('Team meeting today.')
elseif eq(day,bitand(day,allMtgs))
    disp('Meeting today.')
else
    disp('No meetings today!')
end
end

```

Use the `RemindMe` function:

```

today = NetDocEnum.MyDays.Monday;
RemindMe(today)

```

Meeting today.

Read Special System Folder Path

```

function result = getSpecialFolder(arg)
% Returns the special system folders such as "Desktop", "MyMusic" etc.
% arg can be any one of the enum element mentioned in this link
% http://msdn.microsoft.com/en-us/library/system.environment.specialfolder.
% e.g.
%     >> getSpecialFolder('Desktop')
%
%     ans =
%     C:\Users\jsmith\Desktop

%get the type of SpecialFolder enum, this is a nested enum type.
specialFolderType = System.Type.GetType(...
    'System.Environment+SpecialFolder');
%Get a list of all SpecialFolder enum values
folders = System.Enum.GetValues(specialFolderType);
enumArg = [];

%Find the matching enum value requested by the user
for i=1:folders.Length
    if (strcmp(char(folders(i)), arg))

```

```
        enumArg = folders(i);
    break;
end
end

%Validate
if isempty(enumArg)
    error('Invalid Argument');
end

%Call GetFolderPath method and return the result
result = System.Environment.GetFolderPath(enumArg);
end
```

Limitations to Support of .NET Enumerations

You cannot create arrays of .NET enumerations, or any .NET objects, in MATLAB.

.NET Generic Classes in MATLAB

In this section...

“.NET Generic Classes” on page 8-61

“Accessing Items in .NET Collections” on page 8-62

“Create .NET Collections” on page 8-62

“Convert .NET Collections to MATLAB Arrays” on page 8-64

“Create .NET Arrays of Generic Type” on page 8-65

“Call .NET Generic Methods” on page 8-66

“Display .NET Generic Methods Using Reflection” on page 8-68

.NET Generic Classes

Generics are classes and methods that have placeholders (type parameters or *parameterized types*) for one or more types. This lets you design classes that take in a generic type and determine the actual type at run time. A common use for generic classes is to work with collections. For information about generic methods, see “Call .NET Generic Methods” on page 8-66.

The `NET.createGeneric` function creates an instance of the specialized generic class given the following:

- Fully qualified name of the generic class definition
- List of fully qualified parameter type names for generic type specialization
- Variable list of constructor arguments

Use instances of the `NET.GenericClass` helper class in `NET.createGeneric` function’s parameter type list when specialization requires another parameterized class definition. The class instances serve as parameterized data type definitions and are constructed using fully qualified generic type name and a variable length list of fully qualified type names for generic type specialization. This list can also contain instances of `NET.GenericClass` if an extra nested level of parameterization is required.

Accessing Items in .NET Collections

Use the `Item` property of the `System.Collections.Generic.List` class to get or set an element at a specified index. Since `Item` is a property that takes arguments, MATLAB maps it to a pair of methods to get and set the value. For example, the syntax to use `Item` to get a value is:

Return Type	Name	Arguments
System.String RetVal	Item	(System.Collections.Generic. List<System*String> this, int32 scalar index)

The syntax to use `Item` to set a value is:

Return Type	Name	Arguments
none	Item	(System.Collections.Generic. List<System*String> this, int32 scalar index, System.String value)

Create .NET Collections

This example uses two `System.String` arrays, `d1` and `d2`, to create a generic collection list. It shows how to manipulate the list and access its members.

To create the arrays, type:

```
d1 = NET.createArray('System.String',3);
d1(1) = 'Brachiosaurus';
d1(2) = 'Shunosaurus';
d1(3) = 'Allosaurus';
```

```
d2 = NET.createArray('System.String',4);
d2(1) = 'Tyrannosaurus';
d2(2) = 'Spinosaurus';
d2(3) = 'Velociraptor';
d2(4) = 'Triceratops';
```

Create a generic collection, `dc`, to contain `d1`. The `System.Collections.Generic.List` class is in the `microsoft.collections.generic` assembly, which MATLAB loads automatically.

```
dc = NET.createGeneric('System.Collections.Generic.List',...
    {'System.String'},3)
```

```
System.Collections.Generic.List<System*String> handle
Package: System.Collections.Generic
```

```
Properties:
  Capacity: 3
  Count: 0
```

```
Methods, Events, Superclasses
```

The `List` object `dc` has a `Capacity` of three, but currently is empty (`Count = 0`).

Use the `AddRange` method to add the contents of `d1` to the list. For more information, search the Web for `System.Collections.Generic` and select the `List` class.

```
AddRange(dc,d1);
```

List `dc` now has three items:

```
dc.Count
```

To display the contents, use the `Item` method and zero-based indexing:

```
for i=1:dc.Count
    disp(dc.Item(i-1))
end
```

```
Brachiosaurus
Shunosaurus
Allosaurus
```

Another way to add values is to use the `InsertRange` method. Insert the `d2` array starting at index 1:

```
InsertRange(dc,1,d2);
```

The size of the array has grown to seven. To display the values, type:

```
for i=1:dc.Count; disp(dc.Item(i-1)); end
```

```
Brachiosaurus
Tyrannosaurus
Spinosaurus
Velociraptor
Triceratops
Shunosaurus
Allosaurus
```

The first item in the d2 array ('Tyrannosaurus') is at index 1 in list dc:

```
System.String.Compare(d2(1),dc.Item(1))
```

The System.String.Compare answer, 0, indicates the two values are equal.

Convert .NET Collections to MATLAB Arrays

Use the ToArray method of the System.Collections.Generic.List class to convert a collection to an array. For example, use GetRange to get three values from the list, starting with index 2. Then call ToArray to create a System.String array dArr, and display the results:

```
temp = GetRange(dc,2,3);
dArr = ToArray(temp);
for i=1:dArr.Length; disp(dArr(i)); end
```

```
Spinosaurus
Velociraptor
Triceratops
```

To create a MATLAB array D:

```
D = {char(dArr(1)),char(dArr(2)),char(dArr(3))}
```

```
D =
    'Spinosaurus'    'Velociraptor'    'Triceratops'
```

Now you can use `D` in MATLAB functions. For example, if you type:

```
D'
ans =
    'Spinosaurus'
    'Velociraptor'
    'Triceratops'
```

Sort the array alphabetically:

```
sort(D)
ans =
    'Spinosaurus'    'Triceratops'    'Velociraptor'
```

Create .NET Arrays of Generic Type

This example creates a .NET array of `List<Int32>` generic type.

```
genType = NET.GenericClass('System.Collections.Generic.List',...
    'System.Int32');
arr = NET.createArray(genType, 5)
```

```
arr =
```

```
System.Collections.Generic.List<System*Int32>[] handle
Package: System.Collections.Generic
```

```
Properties:
```

```
    Length: 5
  LongLength: 5
    Rank: 1
  SyncRoot: [1x1 System.Collections.Generic.List<System*Int32>[]]
  IsReadOnly: 0
  IsFixedSize: 1
  IsSynchronized: 0
```

```
Methods, Events, Superclasses
```

Call .NET Generic Methods

A *generic method* declares one or more parameterized types. For more information, search for the term `generics` in the .NET Framework Class Library, as described in “To Learn More About the .NET Framework” on page 8-6.

Use the `NET.invokeGenericMethod` function to call a generic method. How you use the `NET.invokeGenericMethod` depends if the method is static or if it is a member of a generic class, as described in the following topics:

- “Invoke Static Generic Functions” on page 8-67
- “Invoke Generic Functions of a Generic Class” on page 8-68
- “Invoke Static Generic Functions of a Generic Class” on page 8-67

Using the NetDocGeneric Example

The C# example `NetDocGeneric.cs`, in the `matlabroot/extern/examples/NET/NetSample` folder, defines simple generic methods to illustrate the `NET.invokeGenericMethod` syntax. To see the code, open the file in MATLAB Editor. Build the `NetDocGeneric` assembly as described in “Building a .NET Application for MATLAB Examples” on page 8-14.

If you created the assembly `NetDocGeneric` and put it in your `c:\work` folder, type the following MATLAB commands to load the assembly:

```
dllPath = fullfile('c:', 'work', 'NetDocGeneric.dll');  
NET.addAssembly(dllPath);
```

Note The `methods` and `methodsview` functions do not list generic methods. Use the “Display .NET Generic Methods Using Reflection” on page 8-68 example.

Invoke Generic Class Member Function

The `GenMethod` method in `NetDocGeneric.SampleClass` returns the input argument as type `K`. To call `GenMethod`, create an object, `obj`:

```
obj = NetDocGeneric.SampleClass();
```

To convert 5 to an integer parameter type, such as `System.Int32`, call `NET.invokeGenericMethod` with the object:

```
ret = NET.invokeGenericMethod(obj,...
    'GenMethod',...
    {'System.Int32'},...
    5);
```

The `GenMethodWithMixedArgs` method has parameterized typed arguments, `arg1` and `arg2`, and a strongly typed argument, `tf`, of type `bool`. The `tf` flag controls which argument `GenMethodWithMixedArgs` returns. To return `arg1`, use the syntax:

```
ret = NET.invokeGenericMethod(obj, 'GenMethodWithMixedArgs',...
    {'System.Double'},5,6,true);
```

To return `arg2`, use the syntax:

```
ret = NET.invokeGenericMethod(obj, 'GenMethodWithMixedArgs',...
    {'System.Double'},5,6,false);
```

Invoke Static Generic Functions

To invoke static method `GenStaticMethod`, call `NET.invokeGenericMethod` with the fully qualified class name:

```
ret = NET.invokeGenericMethod('NetDocGeneric.SampleClass',...
    'GenStaticMethod',...
    {'System.Int32'},...
    5);
```

Invoke Static Generic Functions of a Generic Class

If a static function is a member of a generic class, create a class definition using the `NET.GenericClass` constructor:

```
genClsDef = NET.GenericClass('NetDocGeneric.SampleGenericClass',...
    'System.Double');
```

To invoke static method `GenStaticMethod` of `SampleGenericClass`, call `NET.invokeGenericMethod` with the class definition:

```
ret = NET.invokeGenericMethod(genClsDef,...
    'GenStaticMethod',...
    {'System.Int32'},...
    5);
```

Invoke Generic Functions of a Generic Class

If a generic method uses the same parameterized type as the generic class, you can call the function directly on the class object. If the generic uses a different type than the class, use the `NET.invokeGenericMethod` function.

Display .NET Generic Methods Using Reflection

showGenericMethods Function

The `showGenericMethods` function, reads a .NET object or a fully qualified class name and returns a cell array of the names of the generic method in the given class or object. Create the following MATLAB functions:

```
function output = showGenericMethods(input)
%if input is a .NET object, get MethodInfo[]
if IsNetObject(input)
    methods = GetType.GetMethods(input);
    %if input is a string, get the type and get get MethodInfo[]
elseif ischar(input) && ~isempty(input)
    type = getType(input);
    if isempty(type)
        disp(strcat(input, ' not found'))
        return
    end
    methods = GetMethods(type);
else
    return;
end
%generate generic method names from MethodInfo[]
output = populateGenericMethods(methods);
```

```

end

function output = populateGenericMethods(methods)
%generate generic method names from MethodInfo[]
index = 1;
for i = 1:methods.Length
    method = methods(i);
    if method.IsGenericMethod
        output{index,1} = method.ToString.char;
        index = index + 1;
    end
end
end

function result = IsNetObject(input)
%must be sub class of System.Object to be a .NET object
result = isa(input,'System.Object');
end

function outputType = getType(input)
%input is a string representing the class name
%First try the static GetType method of Type handle.
%This method can find any type from
%System or mscorlib assemblies
outputType = System.Type.GetType(input,false,false);
if isempty(outputType)
    %Framework's method to get the type failed.
    %Manually look for it in
    %each assembly visible to MATLAB
    assemblies = System.AppDomain.CurrentDomain.GetAssemblies;
    for i= 1:assemblies.Length
        asm = assemblies.Get(i-1);
        %look for a particular type in the assembly
        outputType = GetType(asm,input,false,false);
        if ~isempty(outputType)
            %found the type - done
            break
        end
    end
end
end
end

```

```
end
```

Display Generic Methods in a Class

The `NetDocGeneric` assembly contains a class with generic methods.

```
dllPath = fullfile('c:', 'work', 'NetDocGeneric.dll');
asm = NET.addAssembly(dllPath);
asm.Classes
```

```
ans =
    'NetDocGeneric.SampleClass'
```

Display the methods in `SampleClass`:

```
showGenericMethods('NetDocGeneric.SampleClass')
```

```
ans =
    'K GenMethod[K](K) '
    'K GenMethodWithMixedArgs[K](K, K, Boolean) '
    'K GenStaticMethod[K](K) '
    'K GenStaticMethodWithMixedArgs[K](K, K, Boolean) '
```

Display Generic Methods in a Generic Class

The `NetDocGeneric` assembly contains a generic class with generic methods.

```
dllPath = fullfile('c:', 'work', 'NetDocGeneric.dll');
asm = NET.addAssembly(dllPath);
asm.GenericTypes
```

```
ans =
    'NetDocGeneric.SampleGenericClass`1[T]'
```

Display the methods in `SampleGenericClass`:

```
obj = NET.createGeneric('NetDocGeneric.SampleGenericClass',...
    {'System.Double'});
showGenericMethods(obj)
```

```
ans =
```

```
'System.String ParameterizedGenMethod[K](Double, K)'  
'T GenMethod[T](T)'  
'K GenStaticMethod[K](K)'  
'K GenStaticMethodWithMixedArgs[K](K, K, Boolean)'  
'System.String ParameterizedStaticGenMethod[K](Double, K)'
```

Troubleshooting Security Policy Settings From Network Drives

If you run a .NET command on a MATLAB session started from a network drive, you could see a warning message. To resolve this problem, run the `enableNETfromNetworkDrive.m` file, from the `matlabroot\toolbox\matlab\winfun\NET` folder.

This file adds the following entry to the security policy on your machine to trust the `dotnetcli` assembly, which is the MATLAB interface to .NET module:

- Creates a group named `MathWorks_Zone` with `LocalIntranet` permission.
- Creates a `dotnetcli` subgroup within `MathWorks_Zone`.
- Provides `Full-Trust` to the `dotnetcli.dll` strong name for access to the local intranet.

You must have administrative privileges to make changes to your configuration.

Access a Simple .NET Class

In this section...

“System.DateTime Example” on page 8-73

“Create .NET Object From Constructor” on page 8-74

“View Information About .NET Object” on page 8-74

“Introduction to .NET Data Types” on page 8-77

System.DateTime Example

This example shows how to access functionality already loaded on your system. The topics following the example introduce some key steps and ideas to help you get started using .NET in MATLAB.

The Microsoft .NET Framework class library contains classes, such as `System.DateTime`, you can use in MATLAB. The following code creates an object and uses `DateTime` properties and methods to display information about the current date and time.

```
%Create object for current date and time
dateObj = System.DateTime.Now;

%Display properties
dateObj.DayOfWeek
dateObj.Hour

%Call methods
ToShortTimeString(dateObj)
AddDays(dateObj,7);

%Call static method
System.DateTime.DaysInMonth(dateObj.Year,dateObj.Month)
```

The following topics provide more information about creating and viewing information about objects and an introduction to .NET data types.

For information about the .NET Framework class library, refer to the 3rd party documentation described in “To Learn More About the .NET Framework” on page 8-6.

Create .NET Object From Constructor

The example in the previous section uses the `Now` property to create a `DateTime` object. The following example shows how to create an object using one of the `DateTime` *constructors*.

```
myDate = System.DateTime(2000,1,31);
```

To call this constructor, or any method, you need to know its argument list, or *function signature*. Your vendor product documentation shows the function signatures. You can also display the signatures using the MATLAB `methodsview` function. Type `methodsview('System.DateTime')` and search the list for `DateTime` entries, such as shown in the following table.

Return Type	Name	Arguments
System.DateTime obj	DateTime	(int32 scalar year, etc.

From the .NET Class Framework documentation, the following signature initializes a new instance of the `DateTime` structure to the specified year, month, and day, which is the information required for the `myDate` variable.

Return Type	Name	Arguments
System.DateTime obj	DateTime	(int32 scalar year, int32 scalar month, int32 scalar day)

For more information, see “Reading Method Signatures” on page 8-20.

View Information About .NET Object

Although the vendor documentation contains information about `DateTime` objects, you can use MATLAB commands, like `properties` and `methods`, to display information about .NET objects. For example:

```
%Display an object
dateObj = System.DateTime.Now
%Display its properties
properties System.DateTime
%Display its methods
methods System.DateTime
```

MATLAB displays the following information. (The property values reflect your specific date and time.)

Display of DateTime Object

```
dateObj =
  System.DateTime
  Package: System

Properties:
  Date: [1x1 System.DateTime]
  Day: 11
  DayOfWeek: [1x1 System.DayOfWeek]
  DayOfYear: 11
  Hour: 12
  Kind: [1x1 System.DateTimeKind]
  Millisecond: 413
  Minute: 31
  Month: 1
  Now: [1x1 System.DateTime]
  UtcNow: [1x1 System.DateTime]
  Second: 38
  Ticks: 634303458984133595
  TimeOfDay: [1x1 System.TimeSpan]
  Today: [1x1 System.DateTime]
  Year: 2011
  MinValue: [1x1 System.DateTime]
  MaxValue: [1x1 System.DateTime]
Methods, Superclasses
```

Display of DateTime Properties

Properties for class System.DateTime:

Date
Day
DayOfWeek
DayOfYear
Hour
Kind
Millisecond
Minute
Month
Now
UtcNow
Second
Ticks
TimeOfDay
Today
Year
MinValue
MaxValue

Display of DateTime Methods

Methods for class System.DateTime:

Add	GetType	ToUniversalTime
AddDays	GetTypeCode	addlistener
AddHours	IsDaylightSavingTime	delete
AddMilliseconds	Subtract	eq
AddMinutes	ToBinary	findobj
AddMonths	ToFileTime	findprop
AddSeconds	ToFileTimeUtc	ge
AddTicks	ToLocalTime	gt
AddYears	ToLongDateString	isvalid
CompareTo	ToLongTimeString	le
DateTime	ToOADate	lt
Equals	ToShortDateString	ne
GetDateTimeFormats	ToShortTimeString	notify
GetHashCode	ToString	

Static methods:

Compare	Parse	op_GreaterThan
DaysInMonth	ParseExact	op_GreaterThanOrEqual
FromBinary	SpecifyKind	op_Inequality
FromFileTime	TryParse	op_LessThan
FromFileTimeUtc	TryParseExact	op_LessThanOrEqual
FromOADate	op_Addition	op_Subtraction
IsLeapYear	op_Equality	

For more information, see:

- “Using .NET Properties” on page 8-17
- “Using .NET Methods in MATLAB” on page 8-19

Introduction to .NET Data Types

To use .NET objects in MATLAB, you need to understand how MATLAB treats .NET data types. For example, the following `DateTime` properties and methods create variables of various .NET types:

```
dateObj = System.DateTime.Now;
thisDay = dateObj.DayOfWeek;
thisHour = dateObj.Hour;
thisDate = ToLongDateString(dateObj);
thisTime = ToShortTimeString(dateObj);
monthSize = System.DateTime.DaysInMonth(dateObj.Year, dateObj.Month);
whos
```

Name	Size	Bytes	Class
dateObj	1x1	112	System.DateTime
monthSize	1x1	4	int32
thisDate	1x1	112	System.String
thisDay	1x1	104	System.DayOfWeek
thisHour	1x1	4	int32
thisTime	1x1	112	System.String

MATLAB displays the type as a class name.

To use these variables in MATLAB, consider the following:

- Numeric values (`int32`) — MATLAB preserves .NET numeric types by mapping them into equivalent MATLAB types. In the following example, `h` is type `int32`.

```
h = thisHour + 1;
```

For more information, see “.NET Type to MATLAB Type Mapping” on page 8-117 and “Numeric Types”.

- Strings (`System.String`) — Use the `char` function to convert a `System.String` object to a MATLAB string:

```
disp(['The time is ' char(thisTime)]);
```

- Objects (`System.DateTime`) — Refer to the .NET Framework class library documentation for information about using a `DateTime` object.
- Enumerations (`System.DayOfWeek`) — According to the `DateTime` documentation, `DayOfWeek` is an enumeration. To display the enumeration members, type:

```
enumeration('thisDay')
```

For more information, see “.NET Enumerations in MATLAB” on page 8-46.

For a complete list of supported types and mappings, see “Handling Data Returned from .NET Objects” on page 8-117.

Load a Global .NET Assembly

This example shows you how to make .NET classes visible to MATLAB by loading a global assembly using the `NET.addAssembly` function.

The speech synthesizer class (available in .NET Framework Version 3.0 and above) provides ready-to-use text-to-speech features. For example, type:

```
NET.addAssembly('System.Speech');  
speak = System.Speech.Synthesis.SpeechSynthesizer;  
speak.Volume = 100;  
speak.Speak('You can use .NET Libraries in MATLAB');
```

The speech synthesizer class, like any .NET class, is part of an *assembly*. To work with the class, call `NET.addAssembly` to load the assembly into MATLAB. Your vendor documentation contains the assembly name. For example, search the Microsoft .NET Framework Web site for the `System.SpeechSynthesizer` class. The assembly name is `System.Speech`.

```
NET.addAssembly('System.Speech');
```

The `System.Speech` assembly is a *global* assembly. If your assembly is a *private* assembly, use the full path for the input to `NET.addAssembly`.

The “System.DateTime Example” on page 8-73 does not call `NET.addAssembly` because MATLAB dynamically loads its assembly (`mscorlib`) at startup.

Note You cannot unload an assembly in MATLAB.

For more information, see:

- “An Assembly is a Library of .NET Classes” on page 8-107

Pass Numeric Arguments

In this section...
“Call .NET Methods with Numeric Arguments” on page 8-80
“Use .NET Numeric Types in MATLAB” on page 8-80

Call .NET Methods with Numeric Arguments

When you call a .NET method in MATLAB, MATLAB automatically converts numeric arguments into equivalent .NET types, as shown in the table in “Pass Primitive .NET Types” on page 8-109.

Use .NET Numeric Types in MATLAB

MATLAB automatically converts numeric data returned from a .NET method into equivalent MATLAB types, as shown in the table in “.NET Type to MATLAB Type Mapping” on page 8-117.

Note that MATLAB preserves .NET arrays as the relevant `System.Array` types, for example, `System.Double[]`.

MATLAB has rules for handling integers. If you are familiar with using integer types in MATLAB, and just need a reference to the rules, see the links at the end of this topic.

The default data type in MATLAB is `double`. If the data in your applications uses the default, then you need to pay attention to the numeric outputs of your .NET applications.

For more information, see:

- “Numeric Types”
- “Valid Combinations of Unlike Classes”
- “Combining Unlike Integer Types”
- Nondouble Data Type Support

Pass System.String Arguments

In this section...

“Call .NET Methods with System.String Arguments” on page 8-81

“Use System.String in MATLAB” on page 8-82

Call .NET Methods with System.String Arguments

If an input argument to a .NET method is `System.String`, you can pass a MATLAB string. MATLAB automatically converts a `char` array (string) argument into `System.String`. For example, the following code uses the `System.DateTime.Parse` method to convert a date represented by a string into a `DateTime` object:

```
strDate = '01 Jul 2010 3:33:02 GMT';
convertedDate = System.DateTime.Parse(strDate);
ToShortTimeString(convertedDate)
ToLongDateString(convertedDate)
```

To view the function signature for the `System.DateTime.Parse` method, type:

```
methodsview('System.DateTime')
```

Search the list for `Parse`.

Qualifiers	Return Type	Name	Arguments
Static	System.DateTime RetVal	Parse	(System.String s)

For more information, see:

- “Pass MATLAB Strings” on page 8-111
- Search the MSDN Web site at <http://msdn.microsoft.com/en-us/default.aspx> for the term `System.DateTime`.

Use System.String in MATLAB

This example shows how to use a `System.String` object in a MATLAB function.

Create an object representing the current time.

```
dateObj = System.DateTime.Now;  
thisTime = ToShortTimeString(dateObj);  
class(thisTime)
```

```
ans =  
System.String
```

The current time, `thisTime`, is a `System.String` object.

To display `thisTime` in MATLAB, use the `char` function to convert the `System.String` object to a MATLAB string.

```
disp(['The time is ' char(thisTime)]);
```

For more information, see “How MATLAB Handles `System.String`” on page 8-118.

Pass System.Enum Arguments

In this section...

“Call .NET Methods with System.Enum Arguments” on page 8-83

“Use System.Enum in MATLAB” on page 8-84

Call .NET Methods with System.Enum Arguments

An example of an enumeration is `System.DayOfWeek`. To see how to call a .NET method with this input type, use the `GetAbbreviatedDayName` method in the `System.Globalization.DateTimeFormatInfo` class. The following code displays the abbreviation for “Thursday”.

```
% Create a DayOfWeek object
thisDay = System.DayOfWeek.Thursday;
formatObj = System.Globalization.DateTimeFormatInfo;
% Display the abbreviated name of the specified day based on the
% culture associated with the current DateTimeFormatInfo object.
formatObj.GetAbbreviatedDayName(thisDay)
```

To view the function signature for the `GetAbbreviatedDayName` method, type:

```
methodsview('System.Globalization.DateTimeFormatInfo')
```

Search the list for `GetAbbreviatedDayName`.

Return Type	Name	Arguments
System.String RetVal	GetAbbreviatedDayName	(System.Globalization.DateTimeFormatInfo this, System.DayOfWeek dayofweek)

For more information, see:

- “Overview of .NET Enumerations” on page 8-46

- Search the MSDN Web site at <http://msdn.microsoft.com/en-us/default.aspx> for the term `DateTimeFormatInfo`.

Use System.Enum in MATLAB

In MATLAB, an enumeration is a class having a finite set of named instances. You can work with .NET enumerations using features of the MATLAB enumeration class and some features unique to the .NET Framework. Some ways to use the `System.DayOfWeek` enumeration in MATLAB:

- Display an enumeration member. For example:

```
myDay = System.DateTime.Today;
disp(myDay.DayOfWeek);
```

- Use an enumeration in comparison statements. For example:

```
myDay = System.DateTime.Today;
switch(myDay.DayOfWeek)
    case {System.DayOfWeek.Saturday, System.DayOfWeek.Sunday}
        disp('Weekend')
    otherwise
        disp('Work day')
end
```

- Perform calculations using “Underlying Values” on page 8-48. For example, the underlying type of `DayOfWeek` is `System.Int32` which you can use to perform integer arithmetic. To display the date of the first day of the current week, type:

```
myDay = System.DateTime.Today;
dow = myDay.DayOfWeek;
startDateOfWeek = AddDays(myDay, -double(dow));
ToShortDateString(startDateOfWeek)
```

- Perform bit-wise operations. For examples, see “Creating .NET Enumeration Bit Flags” on page 8-57.

For more information, see:

- “Iterate Through a .NET Enumeration” on page 8-52
- “Use .NET Enumerations to Test for Conditions” on page 8-54
- “Use Bit Flags with .NET Enumerations” on page 8-56

Pass System.Nullable Arguments

This example shows how to handle .NET methods with `System.Nullable` type arguments, whose underlying value type is `double`. The example shows how to call a method with a `System.Nullable` input argument. It uses the MATLAB `plot` function to show to handle a `System.Nullable` output argument.

Build Custom Assembly NetDocNullable

To execute the MATLAB code in this example, build the `NetDocNullable` assembly. The assembly is created with the C# code, `NetDocNullable.cs`, in the `matlabroot/extern/examples/NET/NetSample` folder. To see the code, open the file in MATLAB Editor.

`NetDocNullable` defines method `SetField` which has `System.Nullable` arguments.

SetField Function Signature

Return Type	Name	Arguments
<code>System.Nullable<System*Double></code> <code>RetVal</code>	<code>SetField</code>	<code>(NetDocNullable.MyClass this, System.Nullable<System*Double> db)</code>

To build the `NetDocNullable` assembly, see “Building a .NET Application for MATLAB Examples” on page 8-14.

Load NetDocNullable Assembly

The example assumes you put the assembly in your `c:\work` folder. You can modify the example to change the path, `dllPath`, of the assembly.

```
dllPath = fullfile('c:', 'work', 'NetDocNullable.dll');
asm = NET.addAssembly(dllPath);
obj = NetDocNullable.MyClass;
```

Use the `obj` variable to call `SetField`, which creates a `System.Nullable<System*Double>` value from your input.

Pass System.Nullable Input Arguments

MATLAB automatically converts double and null values to `System.Nullable<System*Double>` objects.

Pass a double value.

```
field1 = SetField(obj,10)

field1 =
  System.Nullable<System*Double>
  Package: System

  Properties:
    HasValue: 1
    Value: 10
  Methods, Superclasses
```

The `HasValue` property is true (1) and the `Value` property is 10.

Pass null value, [].

```
field2 = SetField(obj,[])

field2 =
  System.Nullable<System*Double>
  Package: System

  Properties:
    HasValue: 0
  Methods, Superclasses
```

The `HasValue` property is false (0), and it has no `Value` property.

Handle System.Nullable Output Arguments in MATLAB

Before you use a `System.Nullable` object in MATLAB, first decide how to handle null values. If you ignore null values, you might get unexpected results when you use the value in a MATLAB function.

The `System.Nullable` class provides two techniques for handling null values. To provide special handling for null values, use the `HasValue` property. To treat a null value in the same way as a double, use the `GetValueOrDefault` method.

Create a MATLAB function, `plotValue.m`, which detects null values and treats them differently from numeric values. The input is a `System.Nullable<System*Double>` type. If the input is null, the function displays a message. If the input value is double, it creates a line graph from 0 to the value.

```
function plotValue(x)
% x is System.Nullable<System*Double> type
if (x.HasValue && isfloat(x.Value))
    plot([0 x.Value]);
else
    disp('No Data');
end;
```

The `plotValue` function uses the `HasValue` property of the input argument to detect null values and calls the MATLAB `plot` function using the `Value` property.

Call `plotValue` with variable `field1` to display a line graph.

```
plotValue(field1)
```

Call `plotValue` with the variable `field2`, a null value.

```
plotValue(field2)
```

```
No Data
```

If you do not need special processing for null values, use the `GetValueOrDefault` method. To display the `GetValueOrDefault` function signature, type:

```
methodsview(field1)
```

Look for the following function signature:

GetValueOrDefault Function Signature

Return Type	Name	Arguments
double scalar RetVal	GetValueOrDefault	(System.Nullable <System*Double> this)

This method converts the input variable to double so you can directly call the MATLAB plot function:

```
myData = GetValueOrDefault(field1);
plot([0 myData+2]);
```

The GetValueOrDefault method converts a null value to the default numeric value, 0.

```
defaultData = GetValueOrDefault(field2)
```

```
defaultData =
    0
```

Call plot:

```
plot([0 defaultData]);
```

You can change the default value using the GetValueOrDefault method. Open the methodsview window and look for the following function signature:

GetValueOrDefault Function Signature to Change Default

Return Type	Name	Arguments
double scalar RetVal	GetValueOrDefault	(System.Nullable <System*Double> this, double scalar defaultValue)

Set the defaultValue input argument to a new value, -1, and plot the results for null value field2.

```
defaultData = GetValueOrDefault(field2, -1);  
plot([0 defaultData]);
```

For more information, see:

- “Pass System.Nullable Type” on page 8-111
- “How MATLAB Handles System.Nullable” on page 8-120
- Search the MSDN Web site at <http://msdn.microsoft.com/en-us/default.aspx> for the term System.Nullable.

Set Static .NET Properties

In this section...

“System.Environment.CurrentDirectory Example” on page 8-91

“Do Not Use ClassName.PropertyName Syntax for Static Properties” on page 8-92

System.Environment.CurrentDirectory Example

This example shows you how to set a static property using the `NET.setStaticProperty` function.

The `CurrentDirectory` property in the `System.Environment` class is a static, read/write property. The following code creates a new folder `temp` in the current folder and changes the `CurrentDirectory` property to the new folder.

Set your current folder to a specific path, for example:

```
cd('C:\Work')
```

Set the `CurrentDirectory` property:

```
saveDir = System.Environment.CurrentDirectory;
newDir = [char(saveDir) '\temp'];
mkdir(newDir);
NET.setStaticProperty('System.Environment.CurrentDirectory',newDir)
System.Environment.CurrentDirectory
```

```
ans =
C:\Work\temp
```

To restore the original `CurrentDirectory` value, type:

```
NET.setStaticProperty('System.Environment.CurrentDirectory',saveDir)
```

Do Not Use ClassName.PropertyName Syntax for Static Properties

MATLAB creates a struct array when you use the `ClassName.PropertyName` syntax to set a static property.

The following code creates a structure named `System`:

```
saveDir = System.Environment.CurrentDirectory;
newDir = [char(saveDir) '\temp'];
System.Environment.CurrentDirectory = newDir;
whos
```

Name	Size	Bytes	Class
System	1x1	376	struct
newDir	1x12	24	char
saveDir	1x1	112	System.String

Try to use a member of the `System` namespace.:

```
oldDate = System.DateTime(1992,3,1);
```

```
Reference to non-existent field 'DateTime'.
```

To restore your environment, type:

```
clear System
NET.setStaticProperty('System.Environment.CurrentDirectory',saveDir)
```

Use .NET Properties That Take Arguments

MATLAB represents a property that takes an argument as a method. For example, the `System.String` class has two properties, `Chars` and `Length`. The `Chars` property gets the character at a specified character position in the `System.String` object:

Type:

```
str = System.String('my new string');  
Chars(str,0)
```

```
ans =  
m
```

See “Call .NET Properties That Take an Argument” on page 8-22.

MATLAB Does Not Display Protected Properties

The `System.Windows.Media.ContainerVisual` class, available in .NET Framework Version 3.0 and above, has several protected properties. MATLAB only displays public properties and fields. Type:

```
NET.addAssembly('PresentationCore');  
properties('System.Windows.Media.ContainerVisual')
```

Display Public Properties

Properties for class `System.Windows.Media.ContainerVisual`:

```
Children  
Parent  
Clip  
Opacity  
OpacityMask  
CacheMode  
BitmapEffect  
BitmapEffectInput  
Effect  
XSnappingGuidelines  
YSnappingGuidelines  
ContentBounds  
Transform  
Offset  
DescendantBounds  
DependencyObjectType  
IsSealed  
Dispatcher
```

To see how MATLAB handles property and field C# keywords, see “How MATLAB Maps C# Property and Field Access Modifiers” on page 8-18.

Examples Using .NET Methods

In this section...

“Work with .NET Methods Having Multiple Signatures” on page 8-95

“SampleMethods Class” on page 8-97

“Call .NET Methods With out Keyword” on page 8-98

“Call .NET Methods With ref Keyword” on page 8-98

“Call .NET Methods With params Keyword” on page 8-99

Work with .NET Methods Having Multiple Signatures

To create the `NetSample` assembly, see “Building a .NET Application for MATLAB Examples” on page 8-14.

The `SampleMethodSignature` class defines the three constructors shown in the following table.

Return Type	Name	Arguments
<code>netdoc.SampleMethodSignature obj</code>	<code>SampleMethodSignature</code>	
<code>netdoc.SampleMethodSignature obj</code>	<code>SampleMethodSignature</code>	(double scalar <code>d</code>)
<code>netdoc.SampleMethodSignature obj</code>	<code>SampleMethodSignature</code>	(System.String <code>s</code>)

SampleMethodSignature Class

```
using System;
namespace netdoc
{
    public class SampleMethodSignature
    {
        public SampleMethodSignature ()
        {}
    }
}
```

```
        public SampleMethodSignature (double d)
        { myDoubleField = d; }

        public SampleMethodSignature (string s)
        { myStringField = s; }

        public int myMethod(string strIn, ref double dbRef,
        out double dbOut)
        {
            dbRef += dbRef;
            dbOut = 65;
            return 42;
        }

        private Double myDoubleField = 5.5;
        private String myStringField = "hello";
    }
}
```

Display Function Signature Example

If you have not already loaded the NetSample assembly, type:

```
NET.addAssembly('c:\work\NetSample.dll')
```

Create a SampleMethodSignature object obj:

```
obj = netdoc.SampleMethodSignature;
```

To see the method signatures, type:

```
methods(obj, '-full')
```

Look for the following signatures in the MATLAB output:

```
netdoc.SampleMethodSignature obj SampleMethodSignature
netdoc.SampleMethodSignature obj SampleMethodSignature(double scalar d)
netdoc.SampleMethodSignature obj SampleMethodSignature(System.String s)
```

For more information about argument types, see “Handling Data Returned from .NET Objects” on page 8-117.

SampleMethods Class

To create the NetSample assembly, see “Building a .NET Application for MATLAB Examples” on page 8-14.

The SampleMethods class defines the following methods:

- refTest
- outTest
- paramsTest

SampleMethods Class

```
using System;
namespace netdoc
{
    public class SampleMethods
    {
        //test ref keyword
        public void refTest(ref double db1)
        {
            db1 = db1 * 2;
        }

        //test out keyword
        public void outTest(double db1, out double db2)
        {
            db1 = db1 * 2.35;
            db2 = db1;
        }

        //test params keyword
        public int paramsTest(params int[] num)
        {
            int total = 0;
            foreach (int i in num)
            {
                total = total + i;
            }
            return total;
        }
    }
}
```

```

    }
}
}

```

Load the NetSample assembly:

```
NET.addAssembly('c:\work\NetSample.dll')
```

Call .NET Methods With out Keyword

To capture the output from a method using the out keyword, use the outTest method in the “SampleMethods Class” on page 8-97. Its function signature is shown in the following table.

Return Type	Name	Arguments
double scalar db2	outTest	(netdoc.SampleMethods this, double scalar db1)

Type:

```
obj = netdoc.SampleMethods;
db3 = outTest(obj,6)
```

```
db3 =
    14.1000
```

Call .NET Methods With ref Keyword

To capture the output from a method using the ref keyword, use the refTest method in the “SampleMethods Class” on page 8-97. Its function signature is shown in the following table.

Return Type	Name	Arguments
double scalar db1	refTest	(netdoc.SampleMethods this, double scalar db1)

Type:

```
obj = netdoc.SampleMethods;
db4 = refTest(obj,6)
```

```
db4 =
    12
```

Call .NET Methods With params Keyword

To call a method using a params keyword, use the `paramsTest` method in the “SampleMethods Class” on page 8-97. The function signature is shown in the following table.

Return Type	Name	Arguments
int32 scalar RetVal	paramsTest	(netdoc.SampleMethods this, System.Int32[] num)

Type:

```
obj = netdoc.SampleMethods;
mat = [1, 2, 3, 4, 5, 6];
db5 = paramsTest(obj,mat)
```

```
db5 =
    21
```

Call .NET Methods with Optional Arguments

In this section...

“Setting Up the Examples” on page 8-100

“Skip Optional Arguments” on page 8-100

“Call Overloaded Methods” on page 8-101

Setting Up the Examples

To use the examples in this topic, build the `NetDocOptional` assembly. This C# example, `NetDocOptional.cs` in the `matlabroot/extern/examples/NET/NetSample` folder, defines the methods used in these examples. To see the code, open the file in MATLAB Editor. To build the `NetDocOptional` assembly, see “Building a .NET Application for MATLAB Examples” on page 8-14. The examples assume you put the assembly in your `c:\work` folder. You can modify the examples to change the path to the assembly.

Skip Optional Arguments

This example shows how to use default values in optional arguments using the `Greeting` method.

Greeting Function Signature

Arguments `str1` and `str2` are optional.

Return Type	Name	Arguments
System.String RetVal	Greeting	(<code>NetDocOptional.MyClass</code> this, int32 scalar x, optional<System.String> str1, optional<System.String> str2)

Load the `NetDocOptional` assembly, if it is not already loaded. See “Setting Up the Examples” on page 8-100.

```
dllPath = fullfile('c:', 'work', 'NetDocOptional.dll');  
asm = NET.addAssembly(dllPath);  
obj = NetDocOptional.MyClass;
```

Display the default values.

```
Greeting(obj,0)
```

```
ans =  
hello world
```

Use the default value for `str1`.

```
def = System.Reflection.Missing.Value;  
Greeting(obj,0,def, 'Mr. Jones')
```

```
ans =  
hello Mr. Jones
```

Use the default value for `str2`. You can omit the argument at the end of a parameter list.

```
Greeting(obj,0, 'My')
```

```
ans =  
My world
```

Call Overloaded Methods

This example shows how to use optional arguments with an overloaded method, `calc`.

calc Function Signatures

The following table shows the signatures for `calc`, which adds the input arguments. The difference is the type of optional argument, `y`.

Return Type	Name	Arguments
single scalar RetVal	calc	(NetDocOptional.MyClass this, optional<int32 scalar> x, optional<single scalar> y)
double scalar RetVal	calc	(NetDocOptional.MyClass this, optional<int32 scalar> x, optional<double scalar> y)

Load the `NetDocOptional` assembly, if it is not already loaded. See “Setting Up the Examples” on page 8-100.

```
dllPath = fullfile('c:', 'work', 'NetDocOptional.dll');
asm = NET.addAssembly(dllPath);
obj = NetDocOptional.MyClass;
```

Call `calc` with explicit arguments.

```
calc(obj, 3, 4)
```

```
ans =
     7
```

If you try to use the default values by omitting the parameters, MATLAB cannot determine which signature to use.

```
calc(obj)
```

Cannot choose between the following .NET method signatures due to unspecified optional arguments in the call to 'calc':

```
'NetDocOptional.MyClass.calc(NetDocOptional.MyClass this,
optional<int32 scalar> x, optional<single scalar> y)' and
'NetDocOptional.MyClass.calc(NetDocOptional.MyClass this,
```

```
optional<int32 scalar> x, optional<double scalar> y)'
```

You can resolve this ambiguity by specifying enough additional optional arguments so that there is only one possible matching .NET method.

To use the default values, you must provide both arguments.

```
def = System.Reflection.Missing.Value;  
calc(obj,def,def)  
calc(obj,3,def)  
calc(obj,def,4)
```

```
ans =  
    44
```

```
ans =  
    14
```

```
ans =  
    37
```

Pass Cell Arrays of .NET Data

In this section...

“Example of Cell Arrays of .NET Data” on page 8-104

“Create a Cell Array for Each System.Object” on page 8-105

“Create MATLAB Variables from the .NET Data” on page 8-105

“Call MATLAB Functions with MATLAB Variables” on page 8-105

Example of Cell Arrays of .NET Data

In the “Converting Nested System.Object Arrays” on page 8-28 example, the cell array `mldata` contains data from the `MyGraph.getNewData` method. By reading the class documentation in the source file, you can create the following MATLAB graph:

```
dllPath = fullfile('c:', 'work', 'NetDocCell.dll');
asm = NET.addAssembly(dllPath);
obj = NetDocCell.MyGraph;

% Create cell array containing all data
mldata = cell(obj.getNewData);

% Plot the data and label the graph
figure('Name', char(mldata{1}));
plot(double(mldata{2}(2)))
xlabel(char(mldata{2}(1)));
```

However, keeping track of data of different types and dimensions and the conversions necessary to map .NET data into MATLAB types is complicated using the cell array structure. Here are some tips for working with the contents of nested `System.Object` arrays in MATLAB. After reading data from a .NET method:

- Create cell arrays for all `System.Object` arrays.
- Convert the .NET types to MATLAB types, according to the information in “Handling Data Returned from .NET Objects” on page 8-117.
- Create MATLAB variables for each type within the cell arrays.

- Call MATLAB functions with the MATLAB variables.

Create a Cell Array for Each System.Object

The following statement creates the cell array `mldata`:

```
mldata = cell(obj.getNewData)

mldata =
    [1x1 System.String]    [1x1 System.Object[]]
```

This cell array contains elements of the these types.

To access the contents of the `System.Object` array, create another cell array `mldataPlot`:

```
mldataPlot = cell(mldata{2})

mldataPlot =
    [1x1 System.String]    [1x1 System.Double[]]
```

This cell array contains elements of the these types.

Create MATLAB Variables from the .NET Data

Assign cell data to MATLAB variables and convert:

```
% Create descriptive variables
% Convert System.String to char
mytitle = char(mldata{1});
myxlabel = char(mldataPlot{1});
% Convert System.Double to double
y = double(mldataPlot{2});
```

Call MATLAB Functions with MATLAB Variables

Create a MATLAB graph with this data:

```
% Remove the previous figure
close
% Plot the data and label the graph
figure('Name',mytitle,'NumberTitle','off');
```

```
plot(y)  
xlabel(myxlabel);
```

An Assembly is a Library of .NET Classes

Assemblies are the building blocks of .NET Framework applications; they form the fundamental unit of deployment, version control, reuse, activation scoping, and security permissions. An *assembly* is a collection of types and resources built to work together and form a logical unit of functionality.

To work with a .NET application, you need to make its assemblies visible to MATLAB. How you do this depends on how the assembly is deployed, either privately or globally.

- A *global* assembly is shared among applications and installed in a common directory, called the *Global Assembly Cache* (GAC).
- A *private* assembly is used by a single application.

To load a global assembly into MATLAB, use the short name of the assembly, which is the file name without the extension. To load a private assembly, you need the *full path* (folder and file name with extension) of the assembly. This information is in the your product's vendor documentation for the assembly. Refer to the vendor documentation for everything you need to know to use your product.

The following assemblies from the .NET Framework class library are available at startup. MATLAB dynamically loads them the first time you type "NET." or "System."

- mscorlib.dll
- system.dll

To use any other .NET assembly, load the assembly using the `NET.addAssembly` command. After loading the assembly, you can work with the classes defined by the assembly.

Convert Nested System.Object Arrays

The conversion is not recursive for a `System.Object` array contained within a `System.Object` array. You must use the `cell` function to convert each `System.Object` array.

The C# example `NetDocCell.cs`, in the `matlabroot/extern/examples/NET/NetSample` folder, is used in the following example. To see the code, open the file in MATLAB Editor. Build the `NetDocCell` assembly as described in “Building a .NET Application for MATLAB Examples” on page 8-14.

Set up the path name to your assembly, then load the assembly.

```
dllPath = fullfile('c:', 'work', 'NetDocCell.dll');  
NET.addAssembly(dllPath);
```

Create a cell array, `m1Data`:

```
obj = NetDocCell.MyGraph;  
m1Data = cell(obj.getNewData)
```

```
m1Data =  
    [1x1 System.String]    [1x1 System.Object[]]
```

To access the contents of the `System.Object` array, create another cell array `m1PlotData`:

```
m1PlotData = cell(m1Data{2})
```

```
m1PlotData =  
    [1x1 System.String]    [1x1 System.Double[]]
```

For another example, see “Pass Cell Arrays of .NET Data” on page 8-104.

For information about building an assembly, see “Building a .NET Application for MATLAB Examples” on page 8-14.

Passing Data to .NET Objects

When you make a call in MATLAB to a .NET method or function, MATLAB automatically converts arguments into .NET types. MATLAB performs this conversion on each passed argument, except for arguments that are already .NET objects.

The following topics provide information about passing specific data to .NET:

In this section...
“Pass Primitive .NET Types” on page 8-109
“Pass Cell Arrays” on page 8-110
“Pass Nonprimitive .NET Objects” on page 8-111
“Pass MATLAB Strings” on page 8-111
“Pass System.Nullable Type” on page 8-111
“Pass NULL Values” on page 8-112
“Unsupported MATLAB Types” on page 8-112
“Choosing Method Signatures” on page 8-112
“Example — Choosing a Method Signature” on page 8-113
“Pass Arrays” on page 8-115
“Pass MATLAB Arrays as Jagged Arrays” on page 8-115

Pass Primitive .NET Types

The following table shows the MATLAB base types for passed arguments and the corresponding .NET types defined for input arguments. Each row shows a MATLAB type followed by the possible .NET argument matches, from left to right in order of closeness of the match.

MATLAB Primitive Type Conversion Table

MATLAB Type	Closest Type <----- Other Matching .NET Types -----> Least Close Type Preface Each .NET Type with System.											
logical	Boolean	Byte	SByte	Int16	UInt16	Int32	UInt32	Int64	UInt64	Single	Double	Object
double	Double	Single	Decimal	Int64	UInt64	Int32	UInt32	Int16	UInt16	SByte	Byte	Object
single	Single	Double	Decimal	Object								
int8	SByte	Int16	Int32	Int64	Single	Double	Object					
uint8	Byte	UInt16	UInt32	UInt64	Single	Double	Object					
int16	Int16	Int32	Int64	Single	Double	Object						
uint16	UInt16	UInt32	UInt64	Single	Double	Object						
int32	Int32	Int64	Single	Double	Object							
uint32	UInt32	UInt64	Single	Double	Object							
int64	Int64	Double	Object									
uint64	UInt64	Double	Object									
char	Char	String	Object									

The following primitive .NET argument types do not have direct MATLAB equivalent types. MATLAB passes these types as is:

- System.IntPtr
- System.UIntPtr
- System.Decimal
- enumerated types

Pass Cell Arrays

You can pass a cell array to a .NET property or method expecting an array of System.Object or System.String arguments, as shown in the following table.

MATLAB Cell Array Conversion Table

MATLAB Type	Closest Type <--- Other Matching .NET Types ---> Least Close Type		
Cell array of strings	System.String[]	System.Object[]	System.Object
Cell array (not all strings)	System.Object[]	System.Object	

Elements of a cell can be any of the following supported types:

- Any non-sparse, non-complex built-in numeric type shown in the MATLAB® Primitive Type Conversion Table on page 8-110
- char
- logical
- cell array
- .NET object

Pass Nonprimitive .NET Objects

When calling a method that has an argument of a particular .NET class, you must pass an object that is an instance of that class or its derived classes. You can create such an object using the class constructor, or use an object returned by a member of the class. When a class member returns a .NET object, MATLAB leaves it as a .NET object so you can continue to use it to interact with other class members.

Pass MATLAB Strings

MATLAB automatically converts a string or char array to a .NET System.String object. To pass an array of strings, create a cell array.

Pass System.Nullable Type

You can pass any of the following to a .NET method with System.Nullable<ValueType> input arguments:

- Variable of the underlying <ValueType>
- null value, []
- `System.Nullable<ValueType>` object

When you pass a MATLAB variable of type `ValueType`, MATLAB reads the signature and automatically converts your variable to a `System.Nullable<ValueType>` object. For a complete list of possible `ValueType` values accepted for `System.Nullable<ValueType>`, refer to the MATLAB® Primitive Type Conversion Table on page 8-110.

For examples, see “Pass `System.Nullable` Arguments” on page 8-86.

Pass NULL Values

MATLAB uses empty double ([]) values for reference type arguments.

Unsupported MATLAB Types

You cannot pass the following MATLAB types to .NET methods:

- Structure arrays
- Sparse arrays
- Complex numbers

Choosing Method Signatures

MATLAB chooses the correct .NET method signature (including constructor, static and nonstatic methods) based on the following criteria.

When your MATLAB function calls a .NET method, MATLAB:

- 1** Checks to make sure that the object (or class, for a static method) has a method by that name.
- 2** Determines whether the invocation passes the same number of arguments of at least one method with that name.
- 3** Makes sure that each passed argument can be converted to the type defined for the method.

If all the preceding conditions are satisfied, MATLAB calls the method.

In a call to an overloaded method, if there is more than one candidate, MATLAB selects the one with arguments that best fit the calling arguments, based on the MATLAB® Primitive Type Conversion Table on page 8-110. First, MATLAB rejects all methods that have any argument types that are incompatible with the passed arguments. Among the remaining methods, MATLAB selects the one with the highest fitness value, which is the sum of the fitness values of all its arguments. The fitness value for each argument is how close the MATLAB type is to the .NET type. If two methods have the same fitness, MATLAB chooses the first one defined in the class.

For class types, MATLAB chooses the method signature based on the distance of the incoming class type to the expected .NET class type. The closer the incoming type is to the expected type, the better the match.

The rules for overloaded methods with optional arguments are described in “Determining Which Overloaded Method Is Invoked” on page 8-21.

Example — Choosing a Method Signature

Open a `methodsview` window for the `System.String` class and look at the entries for the `Concat` method:

```
import System.*  
methodsview('System.String')
```

The `Concat` method takes one or more arguments. If the arguments are of type `System.String`, the method concatenates the values. For example, create two strings:

```
str1 = String('hello');  
str2 = String('world');
```

When you type:

```
String.Concat(str1,str2)
```

MATLAB verifies the method `Concat` exists and looks for a signature with two input arguments. The following table shows the two signatures.

Qualifiers	Return Type	Name	Arguments
Static	System.String RetVal	Concat	(System.Object arg0, System.Object arg1)
Static	System.String RetVal	Concat	(System.String str0, System.String str1)

Since `str1` and `str2` are of class `System.String`, MATLAB chooses the second signature and displays:

```
ans =
helloworld
```

If the arguments are of type `System.Object`, the method displays the string representations of the values. For example, create two `System.DateTime` objects:

```
objDate = DateTime.Today;
myDate = System.DateTime(objDate.Year,3,1,11,32,5);
```

When you type:

```
String.Concat(objDate,myDate)
```

MATLAB chooses the following signature, since `System.DateTime` objects are derived from the `System.Object` class.

Qualifiers	Return Type	Name	Arguments
Static	System.String RetVal	Concat	(System.Object arg0, System.Object arg1)

This `Concat` method first applies the `ToString` method to the objects, then concatenates the strings. MATLAB displays information like:

```
ans =
12/23/2008 12:00:00 AM3/1/2008 11:32:05 AM
```

Pass Arrays

For information about passing MATLAB arrays to .NET methods, see “Using Arrays with .NET Applications” on page 8-27 and “Pass MATLAB Arrays as Jagged Arrays” on page 8-115.

How Array Dimensions Affect Conversion

The dimension of a .NET array is the number of subscripts required to access an element of the array. To get the number of dimensions, use the `Rank` property of the `.NET System.Array` type. The dimensionality of a MATLAB array is the number of non-singleton dimensions in the array.

MATLAB matches the array dimensionality with the .NET method signature, as long as the dimensionality of the MATLAB array is lower than or equal to the expected dimensionality. For example, you can pass a scalar input to a method that expects a 2-D array.

For a MATLAB array with number of dimensions, `N`, if the .NET array has fewer than `N` dimensions, the MATLAB conversion drops singleton dimensions, starting with the first one, until the number of remaining dimensions matches the number of dimensions in the .NET array.

Converting a MATLAB Array to `System.Object`

You can pass a MATLAB array to a method that expects a `System.Object`.

Pass MATLAB Arrays as Jagged Arrays

A MATLAB array is a rectangular array. The .NET Framework supports a *jagged array*, which is an array of arrays. This means the elements of a jagged array can be of different dimensions and sizes.

Although .NET languages support jagged arrays, the term *jagged* is not a language keyword. C# function signatures use multiple pairs of square brackets (`[][]`) to represent a jagged array. In addition, a jagged array can be nested (`[][][]`), multidimensional (`[,]`), or nested with multidimensional elements (for example, `[, ,][,][]`).

MATLAB automatically converts MATLAB arrays of numeric types to the corresponding jagged array type. If the input argument is a non-numeric type

or multidimensional, use the `NET.createArray` function to create an array to pass as a jagged array. For examples using `NET.createArray`, see “Pass Jagged Arrays” on page 8-31.

Handling Data Returned from .NET Objects

In this section...

“.NET Type to MATLAB Type Mapping” on page 8-117

“How MATLAB Handles System.String” on page 8-118

“How MATLAB Handles System.__ComObject” on page 8-119

“How MATLAB Handles System.Nullable” on page 8-120

“How MATLAB Handles dynamic Type” on page 8-121

“How MATLAB Handles Jagged Arrays” on page 8-121

.NET Type to MATLAB Type Mapping

The following table shows how MATLAB converts data from a .NET object into MATLAB types. These are the values displayed in a method signature.

C# .NET Type	MATLAB Type
System.Int16	int16 scalar
System.UInt16	uint16 scalar
System.Int32	int32 scalar
System.UInt32	uint32 scalar
System.Int64	int64 scalar
System.UInt64	uint64 scalar
System.Single	single scalar
System.Double	double scalar
System.Boolean	logical scalar
System.Byte	uint8 scalar
System.Enum	enum
System.Char	char
System.Decimal	System.Decimal
System.Object	System.Object

C# .NET Type	MATLAB Type
System.IntPtr	System.IntPtr
System.UIntPtr	System.UIntPtr
System.String	System.String
System.Nullable<ValueType>	System.Nullable<ValueType>
System.Array	See “Using Arrays with .NET Applications” on page 8-27
System.__ComObject	See “How MATLAB Handles System.__ComObject” on page 8-119
<i>class name</i>	<i>class name</i>
<i>struct name</i>	<i>struct name</i>

How MATLAB Handles System.String

Use the `char` function to convert a `System.String` object to a MATLAB string. For example, type:

```
str = System.String('create a System.String');
strml = char(str);
whos
```

Name	Size	Bytes	Class
str	1x1	60	System.String
strml	1x22	44	char

MATLAB displays the string value of `System.String` objects, instead of the standard object display. For example, type:

```
a = System.String('test')
b = String.Concat(a, ' hello', ' world')
```

```
a =
test
b =
test hello world
```

The `System.String` class illustrates how MATLAB handles fields and properties, as described in “Call .NET Properties That Take an Argument” on page 8-22. To see reference information about the class, search for the term `System.String` in the .NET Framework Class Library, as described in “To Learn More About the .NET Framework” on page 8-6.

How MATLAB Handles `System.__ComObject`

The `System.__ComObject` type represents a Microsoft COM object. It is a non-visible, public class in the `mscorlib` assembly with no public methods. Under certain circumstances, a .NET object returns an instance of `System.__ComObject`. MATLAB handles the `System.__ComObject` based on the return types defined in the metadata.

MATLAB Converts Object

If the return type of a method or property is strongly typed, and the result of the invocation is `System.__ComObject`, MATLAB automatically converts the returned object to the appropriate type.

For example, suppose your assembly defines a type, `TestType`, and provides a method, `GetTestType`, with the following signature.

Return Type	Name	Arguments
<code>NetDocTest.TestType RetVal</code>	<code>GetTestType</code>	<code>(NetDocTest.MyClass this)</code>

The return type of `GetTestType` is strongly typed and the .NET Framework returns an object of type `System.__ComObject`. MATLAB automatically converts the object to the appropriate type, `NetDocTest.TestType`, shown in the following **pseudo-code**:

```
obj = NetDocTest.MyClass;
var = GetTestType(obj)
```

```
var =
```

```
NetDocTest.TestType handle with no properties.
Package: NetDocTest
```

Methods, Events, Superclasses

Casting Object to Appropriate Type

If the return type of a method or property is `System.Object`, and the result of the invocation is `System.__ComObject`, MATLAB returns `System.__ComObject`. To use the returned object, you must cast it to a valid class or interface type. Use your product documentation to identify the valid types for this object.

To call a member of the new type, cast the object using the MATLAB conversion syntax:

```
objConverted = namespace.className(obj)
```

where `obj` is a `System.__ComObject` type.

For example, an item in a Microsoft Excel® sheet collection can be a chart or a worksheet. The following command converts the `System.__ComObject` variable `mySheet` to a `Chart` or a `Worksheet` object `newSheet`:

```
newSheet = Microsoft.Office.Interop.Excel.interfacename(mySheet);
```

where `interfacename` is `Chart` or `Worksheet`. For an example, see “Work with Microsoft® Excel® Spreadsheets Using .NET” on page 8-123.

Pass a COM Object Between Processes

If you pass a COM object to or from a function, you must lock the object so that MATLAB does not automatically release it when the object goes out of scope. To lock the object, call the `NET.disableAutoRelease` function. You must then unlock the object, using the `NET.enableAutoRelease` function, after you are through using it.

How MATLAB Handles System.Nullable

If .NET returns a `System.Nullable` type, MATLAB returns the corresponding `System.Nullable` type.

A `System.Nullable` type lets you assign null values to types, such as numeric types, that do not support null value. To use a `System.Nullable` object in MATLAB, you first need to decide how to handle null values.

- If you want to process null values differently from `<ValueType>` values, use the `HasValue` property.
- If you want every value to be of the underlying `<ValueType>`, use the `GetValueOrDefault` method. This method assigns a default value of type `<ValueType>` to null values.

Use a variable of the object's underlying type where appropriate in any MATLAB expression. For examples, see “Pass `System.Nullable` Arguments” on page 8-86.

How MATLAB Handles dynamic Type

MATLAB handles dynamic types as `System.Object`. For example, the following C# method `exampleMethod` has a dynamic input argument `d` and returns a dynamic output value:

```
public dynamic exampleMethod(dynamic d)
```

The following table shows the corresponding MATLAB function signature.

Return Type	Name	Arguments
<code>System.Object</code> <code>RetVal</code>	<code>exampleMethod</code>	<code>(namespace.className this, System.Object d)</code>

How MATLAB Handles Jagged Arrays

You must convert a .NET jagged array before using it in a MATLAB command. To convert:

- If the shape of the array is rectangular, use the corresponding MATLAB numeric function.
- If the array is not rectangular, use the `cell` function.

If the jagged array is multidimensional, you must individually convert the arrays in each dimension.

Work with Microsoft Excel Spreadsheets Using .NET

This example creates a spreadsheet, copies some data to it, and closes it.
To create a workbook, type:

```
NET.addAssembly('microsoft.office.interop.excel');  
app = Microsoft.Office.Interop.Excel.ApplicationClass;  
books = app.Workbooks;  
newWB = Add(books);  
app.Visible = true;
```

Create a new sheet:

```
sheets = newWB.Worksheets;  
newSheet = Item(sheets,1);
```

`newSheet` is a `System.__ComObject` because `sheets.Item` can return different types, such as a `Chart` or a `Worksheet`. To make the sheet a `Worksheet`, use the command:

```
newWS = Microsoft.Office.Interop.Excel.Worksheet(newSheet);
```

Create some data and write to a range of cells:

```
excelArray = rand(10);  
newRange = Range(newWS, 'A1');  
newRange.Value2 = 'Data from Location A';  
newRange = Range(newWS, 'A3:B12');  
newRange.Value2 = excelArray;
```

Modify cell format and name the worksheet:

```
newFont = newRange.Font;  
newFont.Bold = 1;  
newWS.Name = 'Test Data';
```

If this is a new spreadsheet, use the `SaveAs` method:

```
SaveAs(newWB, 'mySpreadsheet.xlsx');
```

Close and quit:

```
Close(newWB);  
Quit(app);
```

Work with Microsoft Word Documents Using .NET

The following code creates a new Word document:

```
NET.addAssembly('microsoft.office.interop.word');  
wordApp = Microsoft.Office.Interop.Word.ApplicationClass;  
wordDoc = wordApp.Documents;  
newDoc = Add(wordDoc);
```

If you want to type directly into the document, type the MATLAB command:

```
wordApp.Visible = true;
```

Put the cursor into the document window and enter text.

To name the document `myDocument.docx` and save it in the My Documents folder, type:

```
SaveAs(newDoc, 'myDocument.docx');
```

When you are finished, to close the document and application, type:

```
Save(newDoc);  
Close(newDoc);  
Quit(wordApp);
```

Using COM Objects from MATLAB

- “MATLAB COM Integration” on page 9-2
- “Getting Started with COM” on page 9-8
- “Use Internet Explorer Program in a MATLAB Figure” on page 9-11
- “Add Grid ActiveX Control in a Figure” on page 9-17
- “Read Excel Spreadsheet Data” on page 9-25
- “Supported Client/Server Configurations” on page 9-33

MATLAB COM Integration

In this section...

“What Is COM?” on page 9-2

“Concepts and Terminology” on page 9-3

“The MATLAB COM Client” on page 9-5

“The MATLAB COM Automation Server” on page 9-6

“Registering Controls and Servers” on page 9-6

What Is COM?

Note MATLAB supports the Microsoft .NET Framework on the Windows platform. For more information about this alternative, see “Overview Using .NET from MATLAB” on page 8-3.

The Microsoft *Component Object Model (COM)* provides a framework for integrating reusable, binary software components into an application. Because components are implemented with compiled code, the source code can be written in any of the many programming languages that support COM. Upgrades to applications are simplified, as components can simply be swapped without the need to recompile the entire application. In addition, a component’s location is transparent to the application, so components can be relocated to a separate process or even a remote system without having to modify the application.

Using COM, developers and end users can select application-specific components produced by different vendors and integrate them into a complete application solution. For example, a single application might require database access, mathematical analysis, and presentation-quality business graphs. Using COM, a developer can choose a database-access component by one vendor, a business graph component by another, and integrate these into a mathematical analysis package produced by yet a third.

MATLAB software supports COM integration on the Microsoft Windows platform only.

Concepts and Terminology

While the ideas behind COM technology are straightforward, the terminology is not. The meaning of COM terms has changed over time and few concise definitions exist. Here are some terms that you should be familiar with. These are not comprehensive definitions. For a complete description of COM, you'll need to consult outside resources.

- “COM Objects, Clients, and Servers” on page 9-3
- “Interfaces” on page 9-3
- “COM Server Types” on page 9-4
- “Programmatic Identifiers” on page 9-4
- “In-Process and Out-of-Process Servers” on page 9-5

COM Objects, Clients, and Servers

A COM *object* is a software component that conforms to the Component Object Model. COM enforces encapsulation of the object, preventing direct access of its data and implementation. COM objects expose “Interfaces” on page 9-3, which consist of properties, methods and events.

A COM *client* is a program that makes use of COM objects. COM objects that expose functionality for use are called COM *servers*. COM servers can be in-process or out-of-process. An example of an out-of-process server is Microsoft Excel spreadsheet program. These configurations are described in “In-Process and Out-of-Process Servers” on page 9-5.

A Microsoft *ActiveX*® *control* is a type of in-process COM server that requires a control container. ActiveX controls typically have a user interface. An example is the Microsoft Calendar control. A control container is an application capable of hosting ActiveX controls. A MATLAB figure window or a Simulink® model are examples of control containers.

MATLAB can be used as either a COM client or COM server.

Interfaces

The functionality of a component is defined by one or more interfaces. To use a COM component, you must learn about its interfaces, and the methods,

properties, and events implemented by the component. The component vendor provides this information.

There are two standard COM interfaces:

- **IUnknown** — An interface required by all COM components. All other COM interfaces are derived from IUnknown.
- **IDispatch** — An interface that exposes objects, methods and properties to applications that support Automation.

COM Server Types

There are three types of COM servers:

- **Automation** — A server that supports the OLE Automation standard. Automation servers are based on the IDispatch interface. Automation servers can be accessed by clients of all types, including scripting clients.
- **Custom** — A server that implements an interface directly derived from IUnknown. Custom servers are preferred when faster client access is critical.
- **Dual** — A server that implements a combination of Automation and Custom interfaces.

Programmatic Identifiers

To create an instance of a COM object, you use its programmatic identifier, or *ProgID*. The ProgID is a unique string defined by the component vendor to identify the COM object. You obtain a ProgID from the vendor's documentation.

The MATLAB ProgIDs are

- **Matlab.Application** — Starts a command window Automation server with the version of MATLAB that was most recently used as an Automation server (might not be the latest installed version of MATLAB).
- **Matlab.Autoserver** — Starts a command window Automation server using the most recent version of MATLAB.
- **Matlab.Desktop.Application** — Starts the full desktop MATLAB as an Automation server using the most recent version of MATLAB.

In-Process and Out-of-Process Servers

You can configure a server three ways. MATLAB supports all of these configurations.

- “In-Process Server” on page 9-5
- “Local Out-of-Process Server” on page 9-5
- “Remote Out-of Process Server” on page 9-5

In-Process Server. An in-process server is a component implemented as a dynamic link library (DLL) or ActiveX control that runs in the same process as the client application, sharing the same address space. Communication between client and server is relatively fast and simple.

Local Out-of-Process Server. A local out-of-process server is a component implemented as an executable (EXE) file that runs in a separate process from the client application. The client and server processes are on the same computer system. This configuration is somewhat slower due to the overhead required when transferring data across process boundaries.

Remote Out-of Process Server. This is a type of out-of-process server; however, the client and server processes are on different systems and communicate over a network. Network communications, in addition to the overhead required for data transfer, can make this configuration slower than the local out-of-process configuration. This configuration runs only on systems that support the *Distributed Component Object Model (DCOM)*.

The MATLAB COM Client

Using MATLAB as a COM client provides two techniques for developing programs in MATLAB:

- You can include COM components in your MATLAB application (for example, a spreadsheet).
- You can access existing applications that expose objects via Automation.

In a typical scenario, MATLAB creates ActiveX controls in figure windows, which are manipulated by MATLAB through the controls’ properties, methods, and events. This is useful because there exists a wide variety of

graphical user interface components implemented as ActiveX controls. For example, the Microsoft Internet Explorer® program exposes objects that you can include in a figure to display an HTML file. There also are treeviews, spreadsheets, and calendars available from a variety of sources.

MATLAB COM clients can access applications that support Automation, such as the Excel spreadsheet program. In this case, MATLAB creates an Automation server in which to run the application and returns a handle to the primary interface for the object created.

Information about creating and using COM controls and server objects in MATLAB can be found in “Creating COM Objects” on page 10-2.

The MATLAB COM Automation Server

Automation provides an infrastructure whereby applications called automation controllers can access and manipulate (i.e. set properties of or call methods on) shared automation objects that are exported by other applications, called Automation servers. Any Windows program that can be configured as an Automation controller can control MATLAB.

For example, using Microsoft Visual Basic® programming language, you can run a MATLAB script in a Microsoft PowerPoint® presentation. In this case, PowerPoint is the controller and MATLAB is the server.

Information for creating and connecting to a MATLAB Automation server running MATLAB can be found in “MATLAB COM Automation Server Interface” on page 11-2.

Registering Controls and Servers

Before using COM objects, you must register their controls and servers. Most are registered by default. However, if you get a new .ocx, .dll, or other object file for the control or server, you must register the file manually in the Windows registry.

Use the DOS regsvr32 command to register your file. From the DOS prompt, use the cd function to go to the folder containing the object file. If your object file is an .ocx file, type:

```
regsvr32 filename.ocx
```

For example, to register the MATLAB control `mwsamp2.ocx`, type:

```
cd matlabroot\toolbox\matlab\winfun\win32
regsvr32 mwsamp2.ocx
```

If you encounter problems with this procedure, please consult a Windows manual or contact your local system administrator.

Accessing COM Controls Created with .NET

If you create a COM control using Microsoft .NET Framework 4, use the DOS `regasm` command with the `/codebase` option to register your file.

Verifying the Registration

Here are several ways to verify that a control or server is registered. These examples use the MATLAB `mwsamp` control. Refer to your Microsoft product documentation for information about using Microsoft Visual Studio or the Microsoft Registry Editor programs.

- Go to the Visual Studio .NET 2003 Tools menu and execute the ActiveX control test container. Click **Edit**, insert a new control, and select `MwSamp Control1`. If you are able to insert the control without any problems, the control is successfully registered. Note that this method only works on controls.
- Open the Registry Editor by typing `regedit` at the DOS prompt. Search for your control or server object by selecting **Find** from the **Edit** menu. It will likely be in the following structure:

```
HKEY_CLASSES_ROOT/progid
```

- Open OLEViewer from the Visual Studio .NET 2003 Tools menu. Look in the following structure for your Control object:

```
Object Classes : Grouped by Component Category : Control :
Your_Control_Object_Name (i.e. Object Classes : Grouped by
Component Category : Control : Mwsamp Control)
```

Getting Started with COM

In this section...
“Introduction to COM” on page 9-8
“Basic COM Functions” on page 9-8

Introduction to COM

A COM client is a program that manipulates COM objects. These objects can run in the MATLAB application or can be part of another application that exposes its objects as a programmatic interface to the application.

This section provides examples that show how to use MATLAB as a COM client.

Note You can also access MATLAB as an Automation server from other applications, such as those written in the Microsoft Visual Basic programming language. For information on this technique, see “MATLAB COM Automation Server Interface” on page 11-2.

Basic COM Functions

To start using COM objects, you need to create the object and get information about it. This section covers the following topics:

- “Creating an Instance of a COM Object” on page 9-8
- “Getting Information About a Particular COM Control” on page 9-9
- “Getting an Object’s ProgID” on page 9-9
- “Registering a Custom Control” on page 9-10

Creating an Instance of a COM Object

Two MATLAB functions enable you to create COM objects:

- `actxcontrol` — Creates an instance of a control in a MATLAB figure.

- `actxserver` — Creates and manipulates objects from MATLAB that are exposed in an application that supports Automation.

Each function returns a *handle* to the object's main interface, which you use to access the object's methods, properties, and events, and any other interfaces it provides.

Getting Information About a Particular COM Control

In general, you can determine what you can do with an object using the methods, `get`, and events functions.

Information about Methods. To list the methods supported by the object *handle*, type:

```
handle.methods
```

Information about Properties. To list the properties of the object *handle*, type:

```
get(handle)
```

To see the value of the property *PropertyName*, type:

```
get(handle, 'PropertyName')
```

Use `set` to change a property value.

Information about Events. To list the events supported by the object *handle*, type:

```
handle.events
```

For more information on calling syntax, see “Getting Interfaces to COM Object” on page 10-60 and “Invoking Methods on an Object” on page 10-34. For more information on events, see “Use Events” on page 10-42.

Getting an Object's ProgID

To get the programmatic identifier (ProgID) of a COM control that is already registered on your computer, use the `actxcontrollist` command. You can also use the **ActiveX Control Selector**, displayed with the command

`activexcontrolselect`. This interface lets you see instances of the controls installed on your computer.

For more information on using these commands, see “Creating an ActiveX Control” on page 10-3.

Registering a Custom Control

If your MATLAB program uses a custom control (e.g., one that you have created especially for your application), you must register it with the Microsoft Windows operating system before you can use it. You can do this from your MATLAB program by issuing an operating system command:

```
!regsvr32 /s filename.ocx
```

where *filename* is the name of the file containing the control. Using this command in your program enables you to provide custom-made controls that you make available to other users by registering the control on their computer when they run your MATLAB program. You might also want to supply versions of a Microsoft ActiveX control to ensure that all users have the same version.

For more information about registration, see “Registering Controls and Servers” on page 9-6.

Use Internet Explorer Program in a MATLAB Figure

This example uses the ActiveX control `Shell.Explorer`, which is exposed by the Microsoft Internet Explorer application, to include an HTML viewer in a MATLAB figure. The figure's window button down function is then used to select a graphics object when the user clicks the graph and load the object's property documentation into the HTML viewer.

Techniques Demonstrated

- Using Internet Explorer from an ActiveX client program.
- Defining a window button down function that displays HTML property documentation for whatever object the user clicks.
- Defining a resize function for the figure that also resizes the ActiveX object container.

Using the Figure to Access Properties

This example creates a larger than normal figure window that contains an axes object and an HTML viewer on the lower part of the figure window. By default, the viewer displays the URL `http://www.mathworks.com`. When you issue a plotting command, such as:

```
surf(peaks(20))
```

the graph displays in the axes.

Click anywhere in the graph to see the property documentation for the selected object.

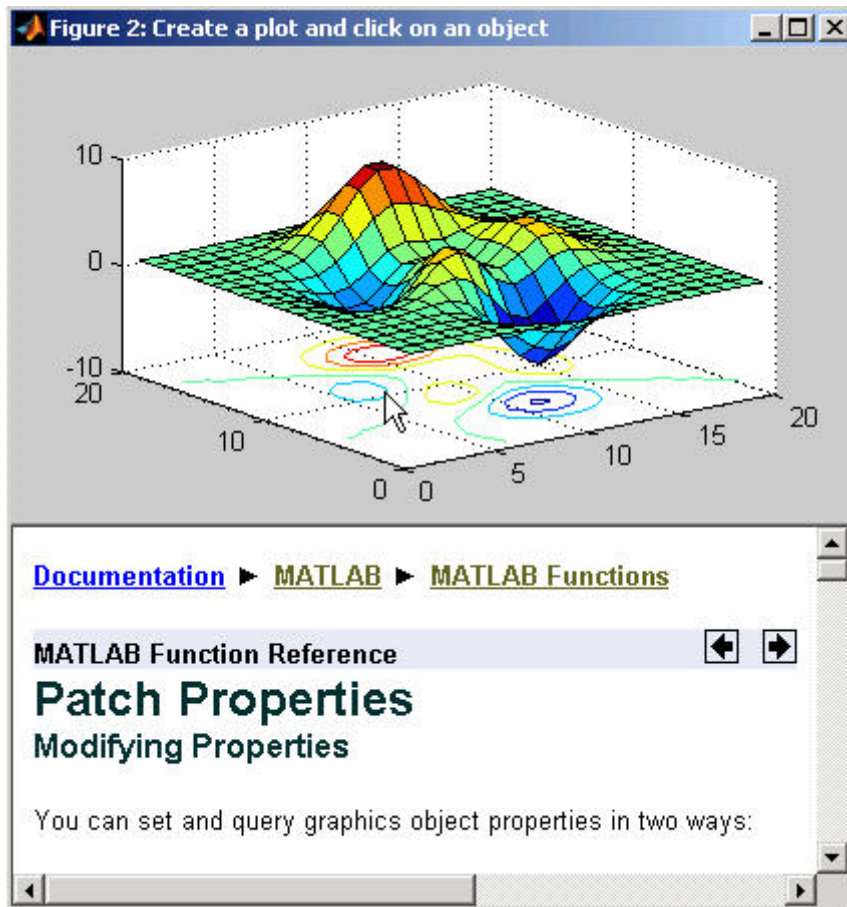

Complete Code Listing

You can open the file that implements this example in MATLAB Editor or you can run this example with the following links:

- [Open file in editor](#)
- [Run this example](#)

Creating the Figure

This example defines the figure size based on the default figure size and adds space for the ActiveX control. Here is the code to define the figure:

```
dfpos = get(0,'DefaultFigurePosition');
hfig = figure('Position',dfpos([1 2 3 4]).* [.8 .2 1 1.65],...
    'Menu','none','Name','Create a plot and click on an object',...
    'ResizeFcn',@reSize,...
    'WindowButtonDownFcn',@wbdf,...
    'Renderer','OpenGL',...
    'DeleteFcn',@figDelete);
```

Note that the figure also defines a resize function and a window button down function by assigning function handles to the `ResizeFcn` and `WindowButtonDownFcn` properties. The callback functions `reSize` and `wbdf` are defined as nested functions in the same file.

The figure's delete function (called when the figure is closed) provides a mechanism to delete the control.

Calculating the ActiveX Object Container Size

The `actxcontrol` function creates the ActiveX control inside the specified figure and returns the control's handle. You need to supply the following information:

- Control's programmatic identifier (use `actxcontrol` to find it)
- Location and size of the control container in the figure (pixels) [left bottom width height]
- Handle of the figure that contains the control:

```
conSize = calcSize; % Calculate the container size
hExp = actxcontrol('Shell.Explorer.2',conSize,hfig); % Create the control
Navigate(hExp,'http://www.mathworks.com/'); % Specify content of html viewer
```

The nested function, `calcSize` calculates the size of the object container based on the current size of the figure. `calcSize` is also used by the figure `resize` function, which is described in the next section.

```
function conSize = calcSize
fp = get(hfig, 'Position');           % Get current figure size
conSize = [0 0 1 .45].*fp([3 4 3 4]); % Calculate container size
end % calcSize
```

Automatic Resize

In MATLAB, you can change the size of a figure and the axes automatically resize to fit the new size. This example implements similar resizing behavior for the ActiveX object container within the figure using the object's `move` method. This method enables you to change both size and location of the ActiveX object container (i.e., it is equivalent to setting the figure `Position` property).

When you resize the figure window, the MATLAB software automatically calls the function assigned to the figure's `ResizeFcn` property. This example implements the nested function `reSize` for the figure `reSize` function.

ResizeFcn at Figure Creation

The `resize` function first determines if the ActiveX object exists because the MATLAB software calls the figure `resize` function when the figure is first created. Since the ActiveX object has not been created at this point, the `resize` function simply returns.

When the Figure Is Resized

When you change the size of the figure, the `resize` function executes and does the following:

- Calls the `calcSize` function to calculate a new size for the control container based on the new figure size.
- Calls the control's `move` method to apply the new size to the control.

Figure ResizeFcn.

```
function reSize(src, evnt)
if ~exist('hExp', 'var')
    return
end
conSize = calcSize;
```

```
move(hExp,conSize);  
end % reSize
```

Selecting Graphics Objects

This example uses the figure `WindowButtonDownFcn` property to define a callback function that handles mouse click events within the figure. When you click the left mouse button while the cursor is over the figure, the MATLAB software executes the `WindowButtonDownFcn` callback on the mouse down event.

The callback determines which object was clicked by querying the figure `CurrentObject` property, which contains the handle of the graphics object most recently clicked. Once you have the object's handle, you can determine its type and then load the appropriate HTML page into the `Shell.Explorer` control.

The nested function `wbdf` implements the callback. Once it determines the type of the selected object, it uses the control `Navigate` method to display the documentation for the object type.

Figure `WindowButtonDownFcn`.

```
function wbdf(src,evt)  
cobj = get(hfig,'CurrentObject');  
if isempty(cobj)  
    disp('Click somewhere else')  
    return  
end  
pth = 'http://www.mathworks.com/help/techdoc/ref/';  
typ = get(cobj,'Type');  
switch typ  
    case ('figure')  
        Navigate(hExp,[pth,'figure_props.html']);  
    case ('axes')  
        Navigate(hExp,[pth,'axes_props.html']);  
    case ('line')  
        Navigate(hExp,[pth,'line_props.html']);  
    case ('image')  
        Navigate(hExp,[pth,'image_props.html']);  
    case ('patch')
```

```
        Navigate(hExp,[pth,'patch_props.html']);
    case ('surface')
        Navigate(hExp,[pth,'surface_props.html']);
    case ('text')
        Navigate(hExp,[pth,'text_props.html']);
    case ('hggroup')
        Navigate(hExp,[pth,'hggroupproperties.html']);
    otherwise % Display property browser
        Navigate(hExp,[pth(1:end-4),'infotool/hgprop/doc_frame.html']);
end
end % wddf
```

Closing the Figure

This example uses the figure delete function (`DeleteFcn` property) to delete the ActiveX object before closing the figure. The MATLAB software calls the figure delete function before deleting the figure, which enables the function to perform any clean up needed before closing the figure. The figure delete function calls the control's delete method.

```
function figDelete(src,evnt)
    hExp.delete;
end
```

Add Grid ActiveX Control in a Figure

This example adds a Microsoft ActiveX spreadsheet control to a figure, which also contains an axes object for plotting the data displayed by the control. Clicking a column in the spreadsheet causes the data in that column to be plotted. Clicking down and dragging the mouse across multiple columns plots all columns touched.

Techniques Demonstrated

- Registering a control for use on your system.
- Writing a handler for one of the control's events and using the event to execute MATLAB plotting commands.
- Writing a `resize` function for the figure that manages the control's size as users resize the figure.

Using the Control

This example assumes that your data samples are organized in columns and that the first cell in each column is a title, which is used by the legend. See "Complete Code Listing" on page 9-18 for an example of how to load data into the control.

Once the data is loaded, click the column to plot the data. The following picture shows a graph of the results of `Test2` and `Test3` created by selecting column B and dragging and releasing on column C.

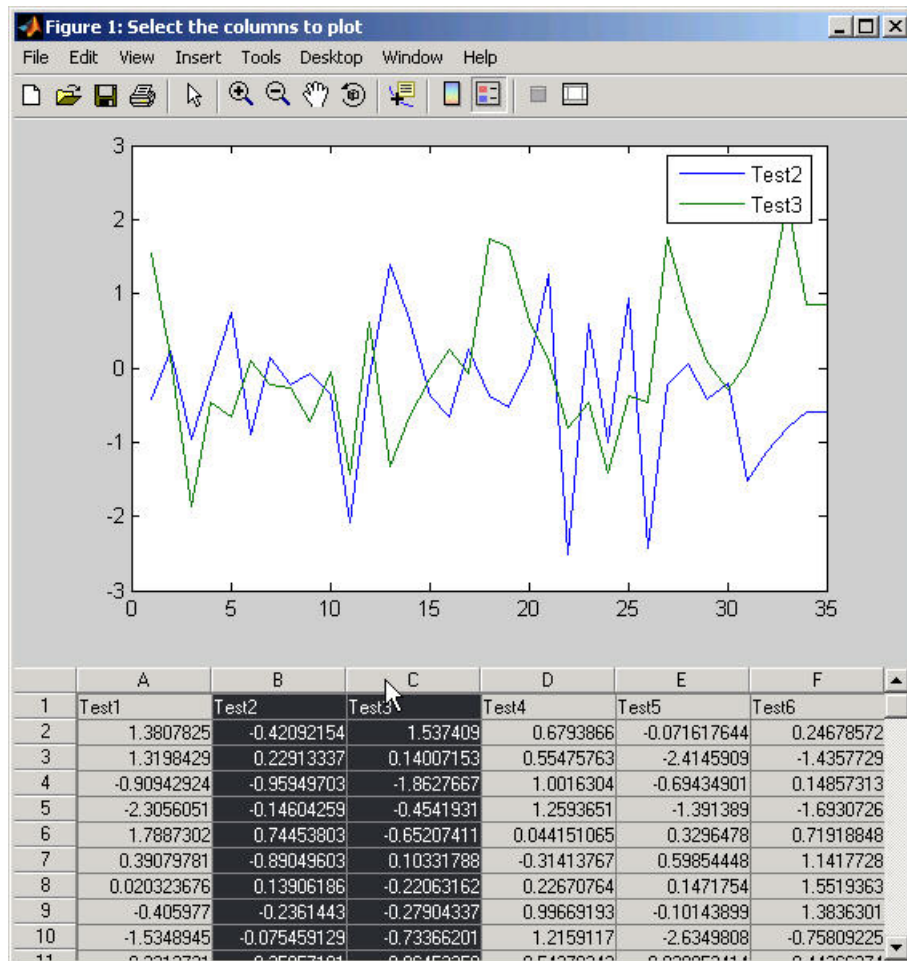

Complete Code Listing

You can open the file used to implement this example in MATLAB Editor:

- Open file in editor.

Preparing to Use the Control

The ActiveX control used in this example is typical of those downloadable from the Internet. Once you have downloaded the files you need, register the control on your system using the DOS command `regsvr32`. In a command prompt, enter a command of the following form:

```
regsvr32 sgrid.ocx
```

From the MATLAB command line, type:

```
system 'regsvr32 sgrid.ocx'
```

See the section “Registering Controls and Servers” on page 9-6 for more information.

Finding the Control’s ProgID

Once you have installed and registered the control, you can obtain its programmatic identifier using the **ActiveX Control Selector** dialog. To display this dialog box, use the `actxcontrolselect` command. Locate the control in the list and the selector displays the control and the ProgID.

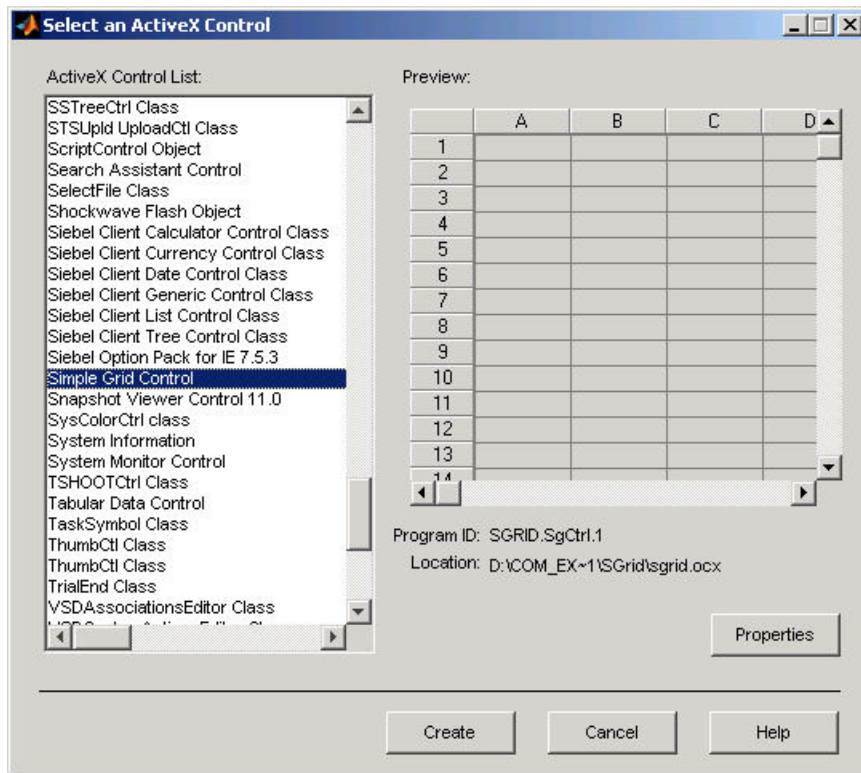

Creating a Figure to Contain the Control

This example creates a figure that contains an axes object and the grid control. The first step is to determine the size of the figure and then create the figure and axes. This example uses the default figure and axes size (obtained from the respective `Position` properties) to calculate a new size and location for each object.

```
dfpos = get(0,'DefaultFigurePosition');
dapos = get(0,'DefaultAxesPosition');
hfig = figure('Position',dfpos([1 2 3 4]).*[1 .8 1 1.25],...
    'Name','Select the columns to plot',...
    'Renderer','ZBuffer',...
    'ResizeFcn',{@reSize dfpos(3)});
hax = axes('Position',dapos([1 2 3 4]).*[1 4 1 .65]);
```

The above code moves the figure down from the top of the screen (multiply second element in position vector by .8) and increases the height of the figure (multiply fourth element in position vector by 1.25). Axes are created and sized in a similar way.

Creating an Instance of the Control

Use the `actxcontrol` function to create an instance of the control in a figure window. This function creates a container for the control and enables you to specify the size of this container, which usually defines the size of the control. See “Managing Figure Resize” on page 9-23 for a specific example.

Specifying the Size and Location

The control size and location in the figure is calculated by a nested function `calcSize`. This function is used to calculate both the initial size of the control container and the size resulting from resize of the figure. It gets the figure’s current position (i.e., size and location) and scales the four-element vector so that the control container is

- Positioned at the lower-left corner of the figure.
- Equal to the figure in width.
- Has a height that is .35 times the figure’s height.

The value returned is of the correct form to be passed to the `actxcontrol` function and the control’s `move` method.

```
function conSize = calcSize
    fp = get(hfig, 'Position');
    conSize = fp([3 4 3 4]).*[0 0 1 .35];
end % conSize
```

Creating the Control

Creating the control entails the following steps:

- Calculating the container size
- Instantiating the control in the figure
- Setting the number of rows and columns to match the size of the data array

- Specifying the width of the columns

```
conSize = calcSize;  
hgrid = actxcontrol('SGRID.SgCtrl.1',conSize,hfig);  
hgrid.NRows = size(dat,1);  
hgrid.NColumns = size(dat,2);  
colwth = 4350; hdwth = hgrid.HdrWidth;  
SetColWidth(hgrid,0,sz(2)-1,colwth,1)
```

Using Mouse-Click Event to Plot Data

This example uses the control's `Click` event to implement interactive plotting. When a user clicks the control, the MATLAB software executes a function that plots the data in the column where the mouse click occurred. Users can also select multiple columns by clicking down and dragging the cursor over more than one column.

Registering the Event

You need to register events with MATLAB so that when the event occurs (a mouse click in this case), the MATLAB software responds by executing the event handler function. Register the event with the `registerevent` function:

```
hgrid.registerevent({'Click',@click_event});
```

Pass the event name (`Click`) and a function handle for the event handler function inside a cell array.

Defining the Event Handler

The event handler function `click_event` uses the control's `GetSelection` method to determine what columns and rows have been selected by the mouse click. This function plots the data in the selected columns as lines, one line per column.

It is possible to click down on a column and drag the mouse to select multiple columns before releasing the mouse. In this case, each column is plotted because the event is not fired until the mouse button is released (which reflects the way the author chose to implement the control). The `legend` function uses the column number stored in the variable `cols` to label the

individual plotted lines. You must add one to `cols` because the control counts the columns starting from zero.

Note that you implement event handlers to accept a variable number of arguments (`varargin`).

```
function click_event(varargin)
[row1,col1,row2,col2] = hgrid.GetSelection(1,1,1,1,1);
ncols = (col2-col1)+1;
cols = [col1:col2];
    for n = 1:ncols
        hgrid.Col = cols(n);
        for ii = 1:sz(1)
            hgrid.Row = ii;
            plot_data(ii,n) = hgrid.Number;
        end
    end
hgrid.SetSelection(row1,col1,row2,col2);
plot(plot_data)
legend(labels(cols+1))
end % click_event
```

Managing Figure Resize

The size and location of a MATLAB axes object is defined in units that are normalized to the figure that contains it. Therefore, when you resize the figure, the axes automatically resize proportionally. When a figure contains objects that are not contained in axes, you are responsible for defining a function that manages the resizing process.

The figure `ResizeFcn` property references a function that executes whenever the figure is resized and also when the figure is first created. This example creates a resize function that manages resizing grid control by doing the following:

- Disables control updates while changes are being made to improve performance (use the `hDisplay` property).
- Calculates a new size for the control container based on the new figure size (`calcSize` function).
- Applies the new size to the control container using its `move` method.

- Scales the column widths of the grid proportional to the change in width of the figure (`SetColWidth` method).
- Refreshes the display of the control, showing the new size.

```
function reSize(src,evnt,dfp)
% Return if control does not exist (figure creation)
if ~exist('hgrid','var')
    return
end
% Resize container
hgrid.bDisplay = 0;
conSize = calcSize;
move(hgrid,conSize);
% Resize columns
scl = conSize(3)/dfp;
ncolwth = scl*colwth;
nhdrwth = hdwth*(scl);
hgrid.HdrWidth = nhdrwth;
SetColWidth(hgrid,0,sz(2)-1,ncolwth,2)
hgrid.Refresh;
end % reSize
```

Closing the Figure

This example uses the figure delete function (`DeleteFcn` property) to delete the ActiveX object before closing the figure. The MATLAB software calls the figure delete function before deleting the figure, which enables the function to perform any clean up needed before closing the figure. The figure delete function calls the control's `delete` method.

```
function figDelete(src,evnt)
    hgrid.delete;
end
```

Read Excel Spreadsheet Data

This example creates a graphical interface to access the data in a Microsoft Excel file. To enable the communication between the MATLAB software and the spreadsheet program, this example creates a Microsoft ActiveX object in an Automation server running an Excel application. The MATLAB software then accesses the data in the spreadsheet through the interfaces provided by the Excel Automation server.

Techniques Demonstrated

This example shows how to use the following techniques:

- Use of an Automation server to access another application from the MATLAB software.
- Ways to manipulate Excel data into types used in the GUI and plotting.
- Implementing a GUI that enables plotting of selected columns of the Excel spreadsheet.
- Inserting a MATLAB figure into an Excel file.

Using the GUI

To use the GUI, select any items in the list box and click the **Create Plot** button. The sample data provided with this example contain three input and three associated response data sets, all of which are plotted versus the first column in the Excel file, which is the time data.

You can view the Excel data file by clicking the **Show Excel Data File** button, and you can save an image of the graph in a different Excel file by clicking **Save Graph** button. Note that the **Save Graph** option creates a temporary PNG file in the current folder, if you have write-access permission.

The following picture shows the GUI with an input/response pair selected in the list box and plotted in the axes.

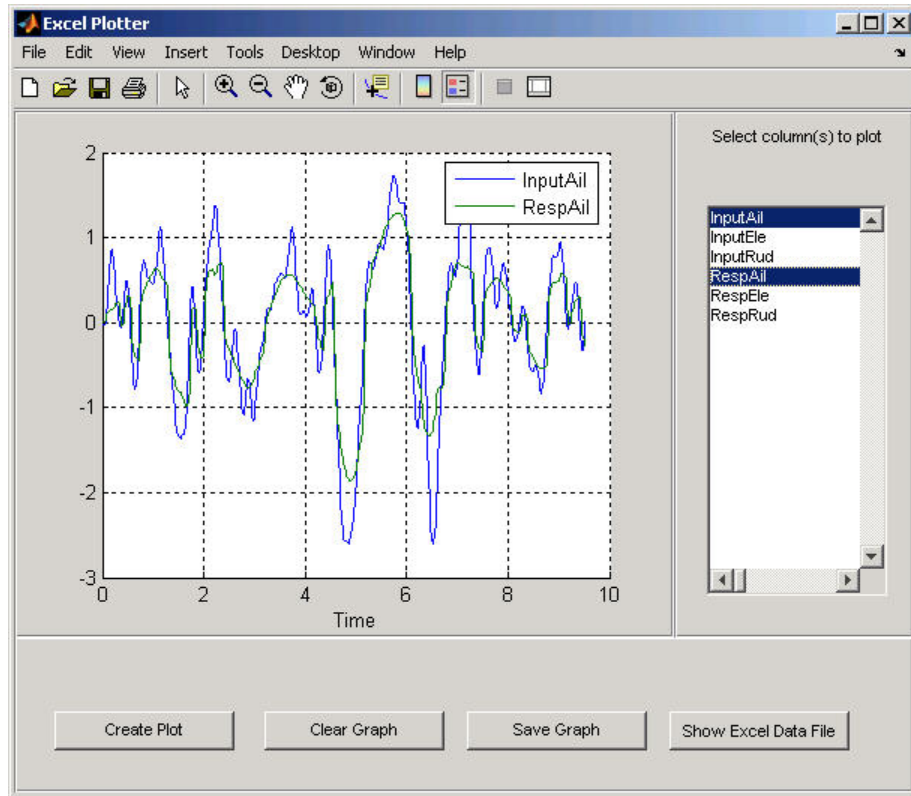

Complete Code Listing

You can open the file used to implement this example in MATLAB Editor or run this example:

- Open file in editor.
- Run this example.

Excel Spreadsheet Format

This example assumes a particular organization of the Excel spreadsheet, as shown in the following picture.

	A	B	C	D	E	F	G
1	Time	InputAil	InputEle	InputRud	RespAil	RespEle	RespRud
2	0	0.00E+00	2.8827	-0.0004868	0	0	0
3	0	0.00E+00	2.8827	-0.0004868	0	0	0
4	0	0.00E+00	2.8827	-0.0004868	0	0	0
5	0.00E+00	0.00E+00	2.8827	-0.0004868	0	0.00E+00	0.00E+00
6	0.00E+00	0.00E+00	2.8827	-0.0004868	0.00E+00	0.00E+00	0.00E+00
7	0.00E+00	0.00E+00	2.8828	-0.0004868	0.00E+00	0.00E+00	0.00E+00
8	0.00E+00	0.00E+00	2.8832	-0.0004868	0.00E+00	0.00E+00	0.00E+00
9	0.00E+00	0.00E+00	2.8853	-0.0004873	0.00E+00	0.00E+00	0.00E+00
10	0.000141	0.00E+00	2.8955	-0.0004995	0.00E+00	0.00E+00	0.00E+00
11	0.000358	0	2.9154	-0.0005692	0.00E+00	0.00035612	0.00E+00
12	0.000358	0	2.9154	-0.0005692	0.00E+00	0.00035612	0.00E+00
13	0.000358	0	2.9154	-0.0005692	0.00E+00	0.00035612	0.00E+00
14	0.000876	0.00E+00	2.9628	-0.0009769	0	0.0021199	0.00E+00
15	0.000876	0.00E+00	2.9628	-0.0009769	0	0.0021199	0.00E+00
16	0.000876	0.00E+00	2.9628	-0.0009769	0	0.0021199	0.00E+00
17	0.000876	0.00E+00	2.9628	-0.0009769	0	0.0021199	0.00E+00
18	0.000876	0.00E+00	2.9628	-0.0009769	0	0.0021199	0.00E+00

The format of the Excel file is as follows:

- The first element in each column is a text string that identifies the data contain in the column. These strings are extracted and used to populate the list box.
- The first column (Time) is used for the x -axis of all plots of the remaining data.
- All rows in each column are read into the MATLAB software.

Excel Automation Server

The first step in accessing the spreadsheet data from the MATLAB software is to run the Excel application in an Automation server process using the `actxserver` function and the program ID, `excel.application`.

```
ex1 = actxserver('excel.application');
```

The ActiveX object that is returned provides access to a number of interfaces supported by the Excel program. Use the workbook interface to open the Excel file containing the data.

```
exlWkbk = exl.Workbooks;  
exlFile = exlWkbk.Open([docroot ' /techdoc/matlab_external/examples/input_resp_data.xls']);
```

Use the workbook's sheet interface to access the data from a range object, which stores a reference to a range of data from the specified sheet. This example accesses all the data in column A, first cell to column G, last cell:

```
exlSheet1 = exlFile.Sheets.Item('Sheet1');  
robj = exlSheet1.Columns.End(4);          % Find the end of the column  
numrows = robj.row;                       % And determine what row it is  
dat_range = ['A1:G' num2str(numrows)]; % Read to the last row  
rngObj = exlSheet1.Range(dat_range);
```

At this point, the entire data set from the Excel file's `sheet1` is accessed via the range object interface. This object returns the data in a MATLAB cell array, which can contain both numeric and character data:

```
exlData = rngObj.Value;
```

Manipulating the Data in the MATLAB Workspace

Now that the data is in a cell array, you can use MATLAB functions to extract and reshape parts of the data into the forms needed to use in the GUI and pass to the plot function.

The following code performs two operations:

- Extracts numeric data from the cell array (indexing with curly braces), concatenates the individual doubles returned by the indexing operation (square brackets), and reshapes it into an array that arranges the data in columns.
- Extracts the string in the first cell in each column of an Excel sheet and stores them in a cell array, which is used to generate the items in the list box.

```
for ii = 1:size(exlData,2)  
    matData(:,ii) = reshape([exlData{2:end,ii}],size(exlData(2:end,ii)));
```

```

    listBox{ii} = [exlData{1,ii}];
end

```

The Plotter GUI

This example uses a GUI that enables you to select from a list of input and response data from a list box. All data is plotted as a function of time (which is, therefore, not a choice in the list box) and you can continue to add more data to the graph. Each data plot added to the graph causes the legend to expand.

Additional implementation details include:

- A legend that updates as you add data to a graph
- A clear button that enables you to clear all graphs from the axes
- A save button that saves the graph as a PNG file and adds it to another Excel file
- A toggle button that shows or hides the Excel file being accessed
- The figure delete function (`DeleteFcn` property), which the MATLAB software calls when the figure is closed, is used to terminate the Automation server process.

Selecting and Plotting Data

When you click the **Create Plot** button, its callback function queries the list box to determine what items are selected and plots each data versus time. The legend is updated to display any new data while maintaining the legend for the existing data.

```

function plotButtonCallback(src,evnt)
iSelected = get(listBox,'Value');
grid(a,'on');hold all
for p = 1:length(iSelected)
    switch iSelected(p)
        case 1
            plot(a,tme,matData(:,2))
        case 2
            plot(a,tme,matData(:,3))
        case 3
            plot(a,tme,matData(:,4))
    end
end

```

```

        case 4
            plot(a,tme,matData(:,5))
        case 5
            plot(a,tme,matData(:,6))
        case 6
            plot(a,tme,matData(:,7))
        otherwise
            disp('Select data to plot')
    end
end
[b,c,g,lbs] = legend([lbs lBoxList(iSelected+1)]);
end % plotButtonCallback

```

Clearing the Axes

The plotter is designed to continually add graphs as the user selects data from the list box. The **Clear Graph** button clears and resets the axes and clears the variable used to store the labels of the plot data (used by legend).

```

%% Callback for clear button
function clearButtonCallback(src,evt)
    cla(a,'reset')
    lbs = '';
end % clearButtonCallback

```

Display or Hide Excel File

The MATLAB program has access to the properties of the Excel application running in the Automation server. By setting the **Visible** property to 1 or 0, this callback controls the visibility of the Excel file.

```

%% Display or hide Excel file
function dispButtonCallback(src,evt)
    exl.visible = get(src,'Value');
end % dispButtonCallback

```

Close Figure and Terminate Excel Automation Process

Since the Excel Automation server runs in a separate process from the MATLAB software, you must terminate this process explicitly. There is no reason to keep this process running after the GUI has been closed, so this

example uses the figure's delete function to terminate the Excel process with the `Quit` method. Also, terminate the second Excel process used for saving the graph. See “Inserting MATLAB Graphs Into Excel Spreadsheets” on page 9-31 for information on this second process.

```
%% Terminate Excel processes
function deleteFig(src,evt)
    ex1Wkbk.Close
    ex1Wkbk2.Close
    ex1.Quit
    ex12.Quit
end % deleteFig
```

Inserting MATLAB Graphs Into Excel Spreadsheets

You can save the graph created with this GUI in an Excel file. (This example uses a separate Excel Automation server process for this purpose.) The callback for the **Save Graph** push button creates the image and adds it to an Excel file:

- Both the axes and legend are copied to an invisible figure configured to print the graph as you see it on the screen (figure `PaperPositionMode` property is set to `auto`).
- The print command creates the PNG image.
- Use the `Shapes` interface to insert the image in the Excel workbook.

The server and interfaces are instanced during GUI initialization phase:

```
ex12 = actxserver('excel.application');
ex1Wkbk2 = ex12.Workbooks;
wb = invoke(ex1Wkbk2,'Add');
graphSheet = invoke(wb.Sheets,'Add');
Shapes = graphSheet.Shapes;
```

The following code implements the **Save Graph** button callback:

```
function saveButtonCallback(src,evt)
    tempfig = figure('Visible','off','PaperPositionMode','auto');
    tempfigfile = [tempname '.png'];
    ah = findobj(f,'type','axes');
```

```
copyobj(ah,tempfig) % Copy both graph axes and legend axes
print(tempfig, '-dpng',tempfigfile);
Shapes.AddPicture(tempfigfile,0,1,50,18,300,235);
ex12.visible = 1;
end
```

Supported Client/Server Configurations

In this section...

- “Introduction” on page 9-33
- “MATLAB Client and In-Process Server” on page 9-33
- “MATLAB Client and Out-of-Process Server” on page 9-34
- “COM Implementations Supported by MATLAB Software” on page 9-35
- “Client Application and MATLAB Automation Server” on page 9-35
- “Client Application and MATLAB Engine Server” on page 9-37

Introduction

You can configure MATLAB software to either control or be controlled by other COM components. When MATLAB controls another component, MATLAB is the client, and the other component is the server. When another component controls MATLAB, MATLAB is the server.

MATLAB Client and In-Process Server

The following diagram shows how the MATLAB client interacts with an “In-Process Server” on page 9-5.

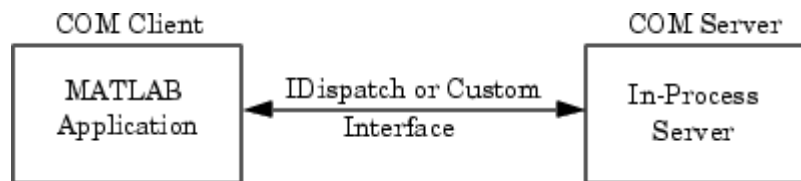

The server exposes its properties and methods through the IDispatch (Automation) interface or a Custom interface, depending on which interfaces the component implements. For information on accessing interfaces, see “Getting Interfaces to COM Object” on page 10-60 .

Microsoft ActiveX Controls

An ActiveX control is an object with some type of graphical user interface (GUI). When the MATLAB software constructs an ActiveX control, it places the control's GUI in a MATLAB figure window. Click the various options available in the user interface (e.g., making a particular menu selection) to trigger *events* that get communicated from the control in the server to the client MATLAB application. The client decides what to do about each event and responds accordingly.

MATLAB comes with a sample ActiveX control called `mwsamp`. This control draws a circle on the screen and displays some text. You can use this control to try out MATLAB COM features. For more information, see “MATLAB Sample Control” on page 10-76.

DLL Servers

Any COM component that has been implemented as a dynamic link library (DLL) is also instantiated in an in-process server. That is, it is created in the same process as the MATLAB client application. When MATLAB uses a DLL server, it runs in a separate window rather than a MATLAB figure window.

MATLAB responds to events generated by a DLL server in the same way as events from an ActiveX control.

For More Information

To learn more about working with MATLAB as a client, see “Creating COM Objects” on page 10-2.

MATLAB Client and Out-of-Process Server

In this configuration, a MATLAB client application interacts with a component that has been implemented as a “Local Out-of-Process Server” on page 9-5. Examples of out-of-process servers are Microsoft Excel and Microsoft Word programs.

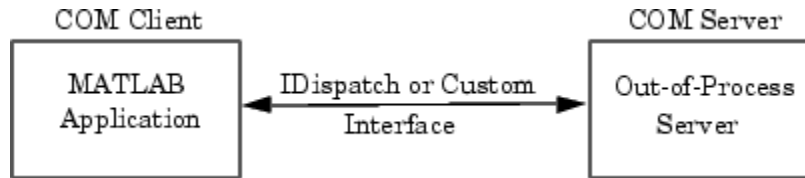

As with in-process servers, this server exposes its properties and methods through the IDispatch (Automation) interface or a Custom interface, depending on which interfaces the component implements. For information on accessing interfaces, see “Getting Interfaces to COM Object” on page 10-60.

Since the client and server run in separate processes, you have the option of creating the server on any system on the same network as the client.

If the component provides a user interface, its window is separate from the client application.

MATLAB responds to events generated by an out-of-process server in the same way as events from an ActiveX control.

For More Information

To learn more about working with MATLAB as a client, see “Creating COM Objects” on page 10-2.

COM Implementations Supported by MATLAB Software

MATLAB only supports COM implementations that are compatible with the Microsoft Active Template Library (ATL) API. In general, your COM object should be able to be contained in an ATL host window in order to work with MATLAB.

Client Application and MATLAB Automation Server

MATLAB operates as the Automation server in this configuration. It can be created and controlled by any Microsoft Windows program that can be an *Automation controller*. Some examples of Automation controllers are

Microsoft Excel, Microsoft Access™, Microsoft Project, and many Microsoft Visual Basic and Microsoft Visual C++ programs.

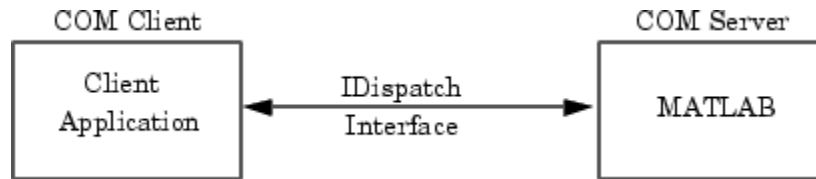

MATLAB Automation server capabilities include the ability to execute commands in the MATLAB workspace, and to get and put matrices directly from and into the workspace. You can start a MATLAB server to run in either a shared or dedicated mode. You also have the option of running it on a local or remote system.

To create the MATLAB server from an external application program, use the appropriate function from that language to instantiate the server. (For example, use the Visual Basic `CreateObject` function.) For the programmatic identifier, specify `matlab.application`. To run MATLAB as a dedicated server, use the `matlab.application.single` programmatic identifier. See “Using MATLAB Software as a Shared or Dedicated Server” on page 11-3 for more information.

The function that creates the MATLAB server also returns a handle to the properties and methods available in the server through the `IDispatch` interface. See “MATLAB Automation Server Functions and Properties” on page 11-7 for descriptions of these methods.

Note Because VBScript client programs require an Automation interface to communicate with servers, this is the only configuration that supports a VBScript client.

For More Information

To learn more about working with Automation servers, see “MATLAB COM Automation Server Interface” on page 11-2.

Client Application and MATLAB Engine Server

MATLAB provides a faster custom interface called IEngine for client applications written in C, C++, or Fortran. MATLAB uses IEngine to communicate between the client application and the MATLAB engine running as a COM server.

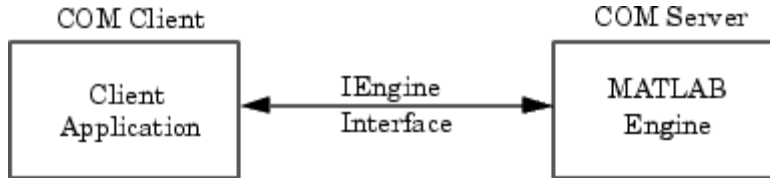

MATLAB provides “The Engine Library” on page 6-4 of functions that let you to start and end the server process, and to send commands to be processed by MATLAB.

For More Information

To learn more about the MATLAB engine and the functions provided in its C/C++ and Fortran API Reference libraries, see “Call MATLAB Engine”.

MATLAB COM Client Support

- “Creating COM Objects” on page 10-2
- “Explore COM Objects” on page 10-12
- “Use Object Properties” on page 10-19
- “Use Methods” on page 10-29
- “Use Events” on page 10-42
- “Getting Interfaces to COM Object” on page 10-60
- “Save COM Objects” on page 10-63
- “Handling COM Data in MATLAB Software” on page 10-65
- “Use MATLAB Application as Automation Client” on page 10-76
- “Deploy ActiveX Controls Requiring Run-Time Licenses” on page 10-81
- “Use Microsoft Forms 2.0 Controls” on page 10-83
- “Use COM Collections” on page 10-85
- “Use MATLAB Application as DCOM Client” on page 10-86
- “MATLAB COM Support Limitations” on page 10-87

Creating COM Objects

In this section...
“Creating the Server Process — An Overview” on page 10-2
“Creating an ActiveX Control” on page 10-3
“Creating a COM Server” on page 10-9

Creating the Server Process — An Overview

MATLAB software provides two functions to create a COM object:

- `actxcontrol` — Creates a Microsoft ActiveX control in a MATLAB figure window.
- `actxserver` — Creates an in-process server for a dynamic link library (DLL) component or an out-of-process server for an executable (EXE) component.

The following diagram shows the basic steps in creating the server process. For more information on how the MATLAB software establishes interfaces to the resultant COM object, see “Getting Interfaces to COM Object” on page 10-60.

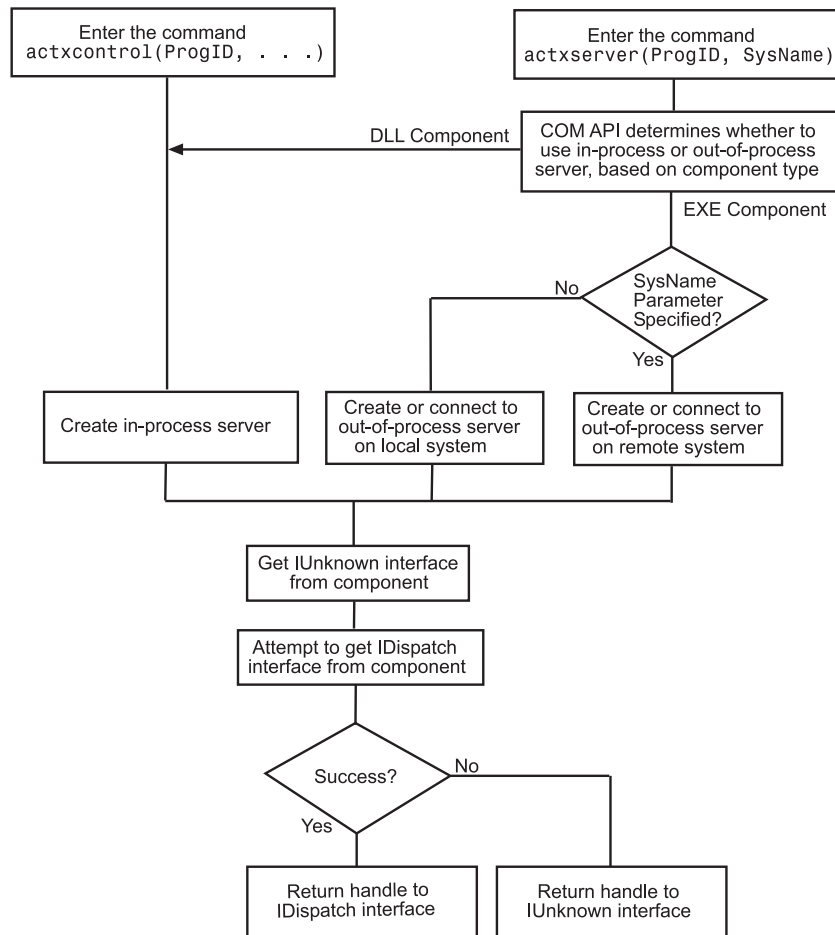

Creating an ActiveX Control

You can create an instance of an ActiveX control from the MATLAB client using either a graphical user interface (GUI) or the `actxcontrol` function from the command line. Either of these methods creates an instance of the control in the MATLAB client process and returns a handle to the primary interface to the COM object. Through this interface, you can access the object's public properties or methods. You can also establish additional

interfaces to the object, including interfaces that use IDispatch, and any custom interfaces that might exist.

This section describes how to create an instance of the control and how to position it in the MATLAB figure window.

- “Listing Installed Controls” on page 10-4
- “Finding a Particular Control” on page 10-5
- “Creating Control Objects Using a GUI” on page 10-5
- “Creating Control Objects from the Command Line” on page 10-8
- “Repositioning the Control in a Figure Window” on page 10-8
- “Limitations to ActiveX Support” on page 10-9

Listing Installed Controls

The `actxcontrol` function shows you what COM controls are currently installed on your system. Type:

```
list = actxcontrol
```

MATLAB displays a cell array listing each control, including its name, programmatic identifier (ProgID), and file name.

This example shows information for several controls (your results might be different):

```
list = actxcontrol;  
s=sprintf(' Name = %s\n ProgID = %s\n File = %s\n', list{114:115,:})
```

MATLAB displays:

```
s =  
Name = OleInstall Class  
ProgID = Outlook Express Mime Editor  
File = OlePrn.OleInstall.1  
Name = OutlookExpress.MimeEdit.1  
ProgID = C:\WINNT\System32\oleprn.dll  
File = C:\WINNT\System32\inetcomm.dll
```

Finding a Particular Control

If you know the name of a control, you can find it in the list and display its ProgID and the path of the folder containing it. For example, some of the examples in this documentation use the `Mwsamp2` control. You can find it with the following code:

```
list = actxcontrollist;
for ii = 1:length(list)
    if ~isempty(strfind([list{ii,:}], 'Mwsamp2'))
        s = sprintf(' Name = %s\n ProgID = %s\n File = %s\n', ...
                    list{ii,:})
    end
end
```

MATLAB displays:

```
s =
  Name = Mwsamp2 Control
  ProgID = MWSAMP.MwsampCtrl.2
  File =
  D:\Apps\MATLAB\R2006a\toolbox\matlab\winfun\win32\mwsamp2.ocx
```

The location of this file might be different on your system.

Creating Control Objects Using a GUI

Using the `actxcontrolselect` function is the simplest way to create an instance of a control object. This function displays a GUI listing all controls installed on your system. When you select an item from the list and click the **Create** button, MATLAB creates the control and returns a handle to it. Type:

```
h = actxcontrolselect
```

MATLAB displays the **Select an ActiveX Control** dialog.

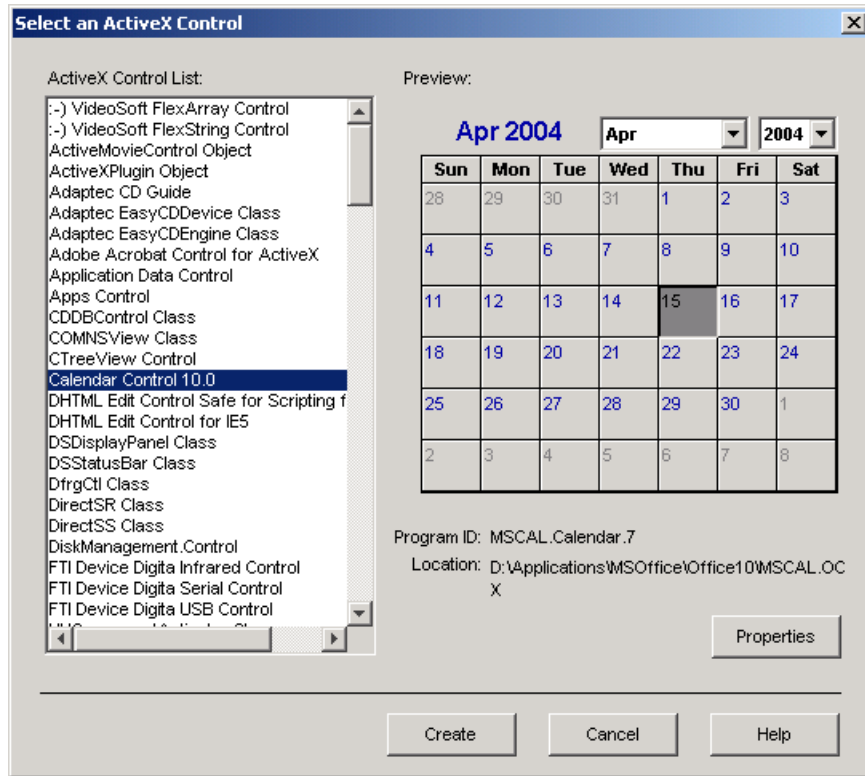

The interface has an **ActiveX Control List** selection pane on the left and a **Preview** pane on the right. Click one of the control names in the selection pane to see a preview of the control. (A blank preview pane means that the control does not have a preview.) An error message appears in the preview pane if MATLAB cannot create the instance.

Setting Properties with `actxcontrolselect`. Click the **Properties** button in the **Preview** pane to change property values when creating the control. You can select which figure window to put the control in (**Parent** field), where to position it in the window (**X** and **Y** fields), and what size to make the control (**Width** and **Height**).

You can register events you want the control to respond to in this window. (For an explanation of event registration, see “Responding to Events — an

Overview” on page 10-44.) Register an event and the callback routine to handle that event by entering the name of the routine to the right of the event under **Event Handler**.

You can select callback routines by clicking a name in the **Event** column, and then clicking the **Browse** button. To assign a callback routine to more than one event, first press the **Ctrl** key and click individual event names, or drag the mouse over consecutive event names, and then click **Browse** to select the callback routine.

MATLAB only responds to registered events, so if you do not specify a callback, the event is ignored.

For example, in the **ActiveX Control List** pane, select **Calendar Control 10.0** (the version on your system might be different) and click **Properties**. MATLAB displays the Choose ActiveX Control Creation Parameter dialog box. Enter a **Width** of 500 and a **Height** of 350 to change the default size for the control. Click **OK** in this window, and click **Create** in the next window to create an instance of the Calendar control.

You can also set control parameters using the `actxcontrol` function. One parameter you can set with `actxcontrol`, but not with `actxcontrolselect`, is the name of an initialization file. When you specify this file name, MATLAB sets the initial state of the control to that of a previously saved control.

Information Returned by `actxcontrolselect`. The `actxcontrolselect` function creates an object that is an instance of the MATLAB COM class. The function returns up to two arguments: a handle for the object, `h`, and a 1-by-3 cell array, `info`, containing information about the control. To get this information, type:

```
[h, info] = actxcontrolselect
```

The cell array `info` shows the name, ProgID, and file name for the control.

If you select the Calendar Control, and then click **Create**, MATLAB displays information like:

```
h =  
    COM.mscal.calendar.7  
info =
```

```
[1x20 char]    'MSCAL.Calendar.7'    [1x41 char]
```

To expand the info cell array, type:

```
info{:}
```

MATLAB displays:

```
ans =  
    Calendar Control 9.0  
ans =  
    MSCAL.Calendar.7  
ans =  
    D:\Applications\MSOffice\Office\MSCAL.OCX
```

Creating Control Objects from the Command Line

If you already know which control you want and you know its ProgID, you can bypass the GUI by using the `actxcontrol` function to create an instance of it.

The ProgID is the only required input to this function. However, as with `actxcontrolselect`, you can supply additional inputs that enable you to select which figure window to put the control in, where to position it in the window, and what size to make it. You can also register any events you want the control to respond to, or set the initial state of the control by reading that state from a file. See the `actxcontrol` reference page for a full explanation of its input arguments.

The `actxcontrol` function returns a handle to the primary interface to the object. Use this handle to reference the object in other COM function calls. You can also use the handle to obtain additional interfaces to the object. For more information on using interfaces, see “Getting Interfaces to COM Object” on page 10-60.

Repositioning the Control in a Figure Window

After creating a control, you can change its shape and position in the window with the `move` function.

Observe what happens to the object created in the last section when you specify new origin coordinates (70, 120) and new width and height dimensions of 400 and 350:

```
h.move([70 120 400 350]);
```

Limitations to ActiveX Support

A MATLAB COM ActiveX control container does not in-place activate controls until they are visible.

Creating a COM Server

Instantiating a DLL Component

To create a server for a component implemented as a dynamic link library (DLL), use the `actxserver` function. MATLAB creates an instance of the component in the same process that contains the client application.

The syntax for `actxserver`, when used with a DLL component, is `actxserver(ProgID)`, where `ProgID` is the programmatic identifier for the component.

`actxserver` returns a handle to the primary interface to the object. Use this handle to reference the object in other COM function calls. You can also use the handle to obtain additional interfaces to the object. For more information on using interfaces, see “Getting Interfaces to COM Object” on page 10-60.

Unlike Microsoft ActiveX controls, any user interface displayed by the server appears in a separate window.

You cannot use a 32-bit in-process DLL COM object in a 64-bit MATLAB application. For information about this restriction, see the Technical Support solution 1-35LZ4G [Why am I not able to use 32-bit DLL COM Objects in 64-bit MATLAB](#).

Instantiating an EXE Component

You can use the `actxserver` function to create a server for a component implemented as an executable (EXE). In this case, MATLAB instantiates the component in an out-of-process server.

The syntax for `actxserver`, when used to create an executable, is `actxserver(ProgID, sysname)`, where `ProgID` is the programmatic identifier for the component, and `sysname` is an optional argument used in configuring a distributed COM (DCOM) system.

`actxserver` returns a handle to the primary interface to the COM object. Use this handle to reference the object in other COM function calls. You can also use the handle to obtain additional interfaces to the object. For more information on using interfaces, see “Getting Interfaces to COM Object” on page 10-60.

Any user interface displayed by the server appears in a separate window.

This example creates a COM server application running the Microsoft Excel spreadsheet program. The handle is assigned to `h`.

```
h = actxserver('Excel.Application')
```

MATLAB displays:

```
h =  
    COM.excel.application
```

MATLAB can programmatically connect to an instance of a COM Automation server application that is already running on your computer. Use the `actxGetRunningServer` function to get a reference to such an application. The syntax is `actxGetRunningServer(ProgID)`, where `ProgID` is the programmatic identifier for the component.

This example gets a reference to the Excel program, which must already be running on your system. The returned handle is assigned to `h`.

```
h = actxGetRunningServer('Excel.Application')
```

MATLAB displays:

```
h =  
    COM.excel.application
```

Explore COM Objects

In this section...
“About Your Object” on page 10-12
“Exploring Properties” on page 10-12
“Exploring Methods” on page 10-14
“Exploring Events” on page 10-14
“Exploring Interfaces” on page 10-15
“Identifying Objects and Interfaces” on page 10-16

About Your Object

A COM object has properties, methods, events, and interfaces. Your vendor documentation describes these features, but you can also learn about your object using MATLAB commands.

Exploring Properties

A *property* is information that is associated with a COM object. This topic shows you how to look at the properties of your object. For detailed information on reading and setting property values, see “Use Object Properties” on page 10-19.

To see a list of all properties of an object, you can use the `get` function or the Property Inspector, a GUI provided by MATLAB to display and modify properties.

In this section, we explore a Microsoft Excel object. To begin, create the object `myApp`:

```
myApp = actxserver('Excel.Application');
```

Listing Properties

The `get` function lists all properties. For example, from the MATLAB command prompt, type:

```
myApp.get
```

MATLAB displays information like the following:

```
    Application: [1x1 Interface.Microsoft_Excel_9.0_
Object_Library._Application]
      Creator: 'xlCreatorCode'
      Parent: [1x1 Interface.Microsoft_Excel_9.0_
Object_Library._Application]
    ActiveCell: []
    ActiveChart: [1x50 char]
           :
    OperatingSystem: 'Windows (32-bit) NT 5.01'
    OrganizationName: 'The MathWorks'
           :
```

One property is `OrganizationName`; its value in this example is `The MathWorks`.

Using the Property Inspector

The Property Inspector opens a new window showing the object's properties. This topic explains how to open it. For detailed information, see “Using the Property Inspector” on page 10-22.

You can open the Property Inspector using either of these methods:

- Call the `inspect` function from the MATLAB command line.
- Double-click the object in the MATLAB Workspace browser.

For example, type:

```
myApp.inspect
```

The Inspector window opens. Scroll down until you see the `OrganizationName` property. It should be the same value the `get` function returned; in this case, `The MathWorks`.

Exploring Methods

A *method* is a procedure you call to perform a specific action on the COM object. This topic shows you how to identify methods belonging to your object. For detailed information, see “Use Methods” on page 10-29.

To see a list of all methods supported by an object, use the `methods` and `invoke` functions. Alternatively, you can use the `methodsview` function, which displays the methods in a separate window.

Exploring Events

An *event* is typically a user-initiated action that takes place in a server application, which often requires a reaction from the client. For example, a user clicking the mouse at a particular location in a server interface window might require the client to take some action in response. When an event is *fired*, the server communicates this occurrence to the client. If the client is *listening* for this particular type of event, it responds by executing a routine called an *event handler*.

This topic shows you how to identify events available to your object. For detailed information, see “Use Events” on page 10-42. For information on event handlers, see “Writing Event Handlers” on page 10-54.

Use the `events` function to list all events known to the control or server and use the `eventlisteners` function to list only registered events.

In this section, we use the Microsoft Internet Explorer Web browser. To begin, create the object `myNet`:

```
myNet = actxserver('internetexplorer.application');
```

Listing Server Events

Type:

```
myNet.events
```

MATLAB displays event information like:

```
      :  
StatusTextChange = void StatusTextChange(string Text)
```

```

ProgressChange = void ProgressChange(int32 Progress,int32 ProgressMax)
CommandStateChange = void CommandStateChange(int32 Command,bool Enable)
:

```

Listing Registered Events

No events are registered at this time. If you type:

```
myNet.eventlisteners
```

MATLAB displays:

```
ans =
     {}
```

Exploring Interfaces

An *interface* is a set of related functions used to access a COM object's data. When you create a COM object using the `actxserver` or `actxcontrol` functions, MATLAB returns a handle to an interface. You use the `get` and `interfaces` functions to see other interfaces implemented by your object.

In this section, we explore an Excel object. To begin, create the object `e`:

```
e = actxserver('Excel.Application');
```

Additional Interfaces

Components often provide additional interfaces, based on `IDispatch`. To see these interfaces, type:

```
e.get
```

MATLAB displays information like:

```

Application: [1x1 Interface.Microsoft_Excel_11.0_Object_Library._Application]
  Creator: 'xlCreatorCode'
  Parent: [1x1 Interface.Microsoft_Excel_11.0_Object_Library._Application]
  ActiveCell: []
  ActiveChart: [1x50 char]
:

```

```
Workbooks: [1x1 Interface.Microsoft_Excel_11.0_Object_Library.Workbooks]
:
```

In this example, `Workbooks` is an interface. To explore the `Workbooks` interface, type:

```
w = e.Workbooks;
```

To see its properties, type:

```
w.get
```

MATLAB displays:

```
Application: [1x1 Interface.Microsoft_Excel_11.0_Object_Library._Application]
Creator: 'xlCreatorCode'
Parent: [1x1 Interface.Microsoft_Excel_11.0_Object_Library._Application]
Count: 0
```

To see its methods, type:

```
w.invoke
```

MATLAB displays:

```
Add = handle Add(handle, Variant(Optional))
Close = void Close(handle)
Item = handle Item(handle, Variant)
Open = handle Open(handle, string, Variant(Optional))
OpenText = void OpenText(handle, string, Variant(Optional))
OpenDatabase = handle OpenDatabase(handle, string, Variant(Optional))
CheckOut = void CheckOut(handle, string)
CanCheckOut = bool CanCheckOut(handle, string)
OpenXML = handle OpenXML(handle, string, Variant(Optional))
```

Identifying Objects and Interfaces

You can get additional information about a control or server using the following functions.

Function	Description
<code>class</code>	Return the class of an object
<code>isa</code>	Determine if an object is of a given MATLAB class
<code>iscom</code>	Determine if the input is a COM or ActiveX object
<code>isevent</code>	Determine if an item is an event of a COM object
<code>ismethod</code>	Determine if an item is a method of a COM object
<code>isprop</code>	Determine if an item is a property of a COM object
<code>isinterface</code>	Determine if the input is a COM interface

This example creates a COM object in an Automation server running the Excel application, giving it the handle `e`, and a `Workbooks` interface to the object, with handle `w`.

```
e = actxserver('Excel.Application');  
w = e.Workbooks;
```

Use the `iscom` function to see if `e` is a handle to a COM object:

```
e.iscom  
ans =  
    1
```

Use the `isa` function to test `e` against a known class name:

```
e.isa('COM.excel_application')  
ans =  
    1
```

Use `isinterface` to see if `w` is a handle to a COM interface:

```
w.isinterface  
ans =  
    1
```

Use the `class` function to find out the class of variable `w`:

```
w.class  
ans =
```

Interface.Microsoft_Excel_11.0_Object_Library.Workbooks

To see if UsableWidth is a property of e, use isprop:

```
e.isprop('UsableWidth')
ans =
     1
```

To see if SaveWorkspace is a method of e, use ismethod:

```
e.ismethod('SaveWorkspace')
ans =
     1
```

Use Object Properties

In this section...
“About Object Properties” on page 10-19
“Working with Multiple Objects” on page 10-20
“Using Enumerated Values for Properties” on page 10-20
“Using the Property Inspector” on page 10-22
“Custom Properties” on page 10-24
“Properties That Take Arguments” on page 10-25

About Object Properties

You can get the value of a property, and, in some cases, change the value. You also can add custom properties. This topic explains how to do these tasks. If you only want to view your object’s properties, see “Exploring Properties” on page 10-12 for basic information.

Property names are not case sensitive. You can abbreviate them as long as the name is unambiguous.

Use these MATLAB functions to work with the properties of a COM object.

Function	Description
addproperty	Add a custom property to a COM object
deleteproperty	Remove a custom property from a COM object
get	List one or more properties and their values
inspect	Display graphical interface to list and modify property values
isprop	Determine if an item is a property of a COM object
propedit	Display the control’s built-in property page
set	Set the value of one or more properties

Working with Multiple Objects

You can use the `get` and `set` functions on more than one object at a time by creating a vector of object handles and using these commands on the vector.

Note To get or set values for multiple objects, use the `get` and `set` functions explicitly. You can only use dot syntax, for example `H.Day`, on scalar objects.

Using Enumerated Values for Properties

Enumeration makes examining and changing properties easier because each possible value for the property is given a string to represent it. For example, one of the values for the `DefaultSaveFormat` property in a Microsoft Excel spreadsheet is `xlUnicodeText`. This is easier to remember than a numeric value like `57`.

This section covers the following topics:

- “Finding All Enumerated Properties” on page 10-20
- “Setting Enumerated Values” on page 10-21
- “Setting Enumerated Values with the Property Inspector” on page 10-22

Finding All Enumerated Properties

The `get` and `set` functions support enumerated values for properties for those applications that provide them. Use the `set` function to see which properties use enumerated types.

For example, create an instance of an Excel spreadsheet:

```
h = actxserver('Excel.Application');
```

Type:

```
h.set
```

MATLAB displays:

```
ans =
```



```

        Creator: {'xlCreatorCode'}
    ConstrainNumeric: {}
    CopyObjectsWithCells: {}
        Cursor: {4x1 cell}
        CutCopyMode: {2x1 cell}
        :
        .

```

MATLAB displays the properties that accept enumerated types as nonempty cell arrays. In this example, `Cursor` and `CutCopyMode` accept a choice of settings. Properties for which there is only one possible setting are displayed as a one row cell array (see `Creator`, above).

Use the `get` function to display the current values of these properties. Type:

```
h.get
```

MATLAB displays information such as:

```

        Creator: 'xlCreatorCode'
    ConstrainNumeric: 0
    CopyObjectsWithCells: 1
        Cursor: 'xlDefault'
        CutCopyMode: ''
        :
        .

```

Setting Enumerated Values

To list all possible enumerated values for a specific property, use `set` with the property name argument. The output is a cell array of strings, one string for each possible setting of the specified property:

```

h.set('Cursor')
ans =
    'xlIBeam'
    'xlDefault'
    'xlNorthwestArrow'
    'xlWait'

```

To set the value of a property, assign the enumerated value to the property name:

```
handle.property = 'enumeratedvalue';
```

You can also use the `set` function with the property name and enumerated value:

```
handle.set('property', 'enumeratedvalue');
```

You have a choice of using the enumeration or its equivalent numeric value. You can abbreviate the enumeration string, as in the third line of the following example, as long as you use enough letters in the string to make it unambiguous. Enumeration strings are not case sensitive.

Make the Excel spreadsheet window visible, and then change the cursor from the MATLAB client. To see how the cursor has changed, click the spreadsheet window. Either of the following assignments to `h.Cursor` sets the cursor to the Wait (hourglass) type:

```
h.Visible = 1;  
  
h.Cursor = 'xlWait'  
h.Cursor = 'xlw'           % Abbreviated form of xlWait
```

Read the value of the `Cursor` property you have just set:

```
h.Cursor  
ans =  
    xlWait
```

Setting Enumerated Values with the Property Inspector

You can also set enumerated values using the Property Inspector. To learn how to use this feature, see “Using the Property Inspector on Enumerated Values” on page 10-23.

Using the Property Inspector

The Property Inspector enables you to access the properties of COM objects. To open the Property Inspector, use the `inspect` function from the MATLAB command line or double-click the object in the MATLAB Workspace browser.

For example, create a server object running the Excel program. Then set the object's `DefaultFilePath` property to `C:\ExcelWork`:

```
h = actxserver('Excel.Application');  
h.DefaultFilePath = 'C:\ExcelWork';
```

Next call the `inspect` function to display a new window showing the server object's properties:

```
h.inspect
```

Scroll down until you see the `DefaultFilePath` property that you just changed. It should read `C:\ExcelWork`.

Using the Property Inspector, change `DefaultFilePath` once more, this time to `MyWorkDirectory`. To do this, select the value at the right and type the new value.

Now go back to the MATLAB Command Window and confirm that the `DefaultFilePath` property has changed as expected.

```
h.DefaultFilePath
```

MATLAB displays:

```
ans =
```

```
C:\MyWorkDirectory
```

Note If you modify properties at the MATLAB command line, refresh the Property Inspector window to see the change reflected there. Refresh the Property Inspector window by reinvoking `inspect` on the object.

Using the Property Inspector on Enumerated Values

A list button next to a property value indicates the property accepts enumerated values. Click anywhere in the field on the right to see the values. The following figure displays four enumerated values for the `Cursor` property. The current value `x1Default` is displayed in the field next to the property name.

To change the value, use the list button to display the options for that property, and then click the desired value.

Custom Properties

You can add your own custom properties to an instance of a control using the `addproperty` function. The syntax `h.addproperty('propertyName')` creates a custom property for control `h`.

This example creates the `mwsamp2` control, adds a new property called `Position` to it, and assigns the value `[200 120]` to that property:

```
h = actxcontrol('mwsamp.mwsampctrl.2', [200 120 200 200]);  
h.addproperty('Position');  
h.Position = [200 120];
```

Use the `get` function to list all properties of control `h`.

```
h.get
```

You see the new `Position` property has been added.

```
ans =  
    Label: 'Label'  
    Radius: 20  
    Position: [200 120]
```

Type:

```
h.Position
```

MATLAB displays:

```
ans =  
    200    120
```

To remove custom properties from a control, use the `deleteproperty` function. The syntax `h.deleteproperty('propertyName')` deletes `propertyName` from `h`. For example, to delete the `Position` property that you just created and show that it no longer exists, type:

```
h.deleteproperty('Position');
```

```
h.get
```

MATLAB displays:

```
ans =  
    Label: 'Label'  
    Radius: 20
```

Properties That Take Arguments

Some COM objects have properties that accept input arguments. Internally, MATLAB handles these properties as methods, which means you need to use the `invoke` function (not `get`) to view the property.

To explain how this works, look at a spreadsheet property that takes input arguments. This example is taken from “Using a MATLAB Application as an Automation Client” on page 10-76.

- “An Example” on page 10-25
- “Exploring the Object” on page 10-26
- “Exploring Values” on page 10-26
- “Setting Values” on page 10-27
- “Completing the Example” on page 10-28

An Example

The Excel Activesheet interface is an object that takes input arguments. This interface has a property called `Range`. To specify `Range`, pass in range coordinates.

To begin, create the `Worksheet` object `ws`:

```
e = actxserver('Excel.Application');  
e.Workbooks.Add;  
ws = e.Activesheet;
```

The `ws` object is an interface:

```
ws =
```

```
Interface.Microsoft_Excel_11.0_Object_Library._Worksheet
```

Exploring the Object

You can explore the `ws` object using the `get` and `invoke` functions. (When you type the following commands, MATLAB displays long lists of properties and methods.) When you type `ws.get`, the property `Range` is not in the list. You must use the `invoke` function to find `Range`.

```
ws.invoke
```

MATLAB displays (in part):

```
      :  
Range = handle Range(handle, Variant, Variant(Optional))  
      :
```

Exploring Values

The `get` function also displays the value of a property. For example, one of the properties listed by `get` is `StandardHeight`. To see its value, type:

```
ws.get('StandardHeight')
```

MATLAB displays:

```
ans =  
    13.2000
```

But, if you use this command on `Range`:

```
ws.get('Range');
```

MATLAB displays:

```
Invoke Error: Incorrect number of arguments
```

Consulting Microsoft reference documentation, you find `Range` requires arguments `A1:B2`, which specify a rectangular region of the spreadsheet.

If you type:

```
wsRange = ws.get('Range', 'A1:B2')
```

MATLAB shows that `wsRange` is an interface:

```
wsRange =  
    Interface.Microsoft_Excel_11.0_Object_Library.Range
```

You find the properties by typing:

```
wsRange.get
```

From the lengthy list MATLAB displays, look at the `Value` property:

```
      :  
    Value: {2x2 cell}  
      :
```

To see the current value, type:

```
wsRange.Value
```

MATLAB displays:

```
ans =  
    [NaN]    [NaN]  
    [NaN]    [NaN]
```

Setting Values

To copy a MATLAB array `A` into the `wsRange` object, type:

```
A = [1 2; 3 4];  
wsRange.Value = A;  
wsRange.Value
```

MATLAB displays:

```
ans =  
    [1]    [2]  
    [3]    [4]
```

Completing the Example

When you are finished with this example, type:

```
e.Workbook.Close;
```

The `Excel Close` method expects a `Yes/No` response about saving the workbook. To terminate and remove the server object, type:

```
e.Quit;  
e.delete;
```

Use Methods

In this section...
“About Methods” on page 10-29
“Getting Method Information” on page 10-30
“Invoking Methods on an Object” on page 10-34
“Exceptions to Using Implicit Syntax” on page 10-36
“Specifying Enumerated Parameters” on page 10-37
“Optional Input Arguments” on page 10-38
“Returning Multiple Output Arguments” on page 10-39
“Argument Callouts in Error Messages” on page 10-40

About Methods

You execute, or *invoke*, COM functions or methods belonging to COM objects. This topic explains how to determine what methods are available for an object and how to invoke them. If you only want to view your object’s methods, see “Exploring Methods” on page 10-14 for basic information.

Method names are case sensitive. You cannot abbreviate them.

Use the following MATLAB functions to work with the methods of a COM object.

Function	Description
<code>invoke</code>	Invoke a method or display a list of methods and types
<code>ismethod</code>	Determine if an item is a method of a COM object
<code>methods</code>	List all method names for the control or server
<code>methodsview</code>	Graphic display of information on all methods and types

Getting Method Information

You can see what methods are supported by a COM object using the `methodsview`, `methods`, or `invoke` functions. Each function presents specific information, as described in the following table.

Function	Output
<code>invoke</code>	Cell array of function names and signatures
<code>methods</code>	Cell array of function names only, sorted alphabetically, with uppercase names listed first
<code>methods</code> with <code>-full</code> qualifier	Cell array of function names and signatures, sorted alphabetically
<code>methodsview</code>	Graphical display of function names and signatures

In this topic, you can use the built-in MATLAB control `mwsamp` to try out these functions. To create the control object `sampObj`, type:

```
sampObj = actxcontrol('mwsamp.mwsampctr1.1', [0 0 500 500]);
```

The control opens a figure window and displays a circle and text label.

Using `invoke`

The `invoke` function returns a cell array containing a list of all methods supported by the object, along with the signatures for these methods. This list is not sorted alphabetically.

For example, type:

```
sampObj.invoke
```

MATLAB displays:

```
Beep = void Beep(handle)
Redraw = void Redraw(handle)
GetVariantArray = Variant GetVariantArray(handle)
GetIDispatch = handle GetIDispatch(handle)
```

```

GetBSTR = string GetBSTR(handle)
GetI4Array = Variant GetI4Array(handle)
GetBSTRArray = Variant GetBSTRArray(handle)
GetI4 = int32 GetI4(handle)
GetR8 = double GetR8(handle)
GetR8Array = Variant GetR8Array(handle)
FireClickEvent = void FireClickEvent(handle)
GetVariantVector = Variant GetVariantVector(handle)
GetR8Vector = Variant GetR8Vector(handle)
GetI4Vector = Variant GetI4Vector(handle)
SetBSTRArray = Variant SetBSTRArray(handle, Variant)
SetI4 = int32 SetI4(handle, int32)
SetI4Vector = Variant SetI4Vector(handle, Variant)
SetI4Array = Variant SetI4Array(handle, Variant)
SetR8 = double SetR8(handle, double)
SetR8Vector = Variant SetR8Vector(handle, Variant)
SetR8Array = Variant SetR8Array(handle, Variant)
SetBSTR = string SetBSTR(handle, string)
AboutBox = void AboutBox(handle)

```

Using methods

The `methods` function returns the names of all methods for the object, including MATLAB COM functions that you can use on the object. There is no information about how to call the method. This list is sorted alphabetically; however, method names with initial caps are listed before methods with lowercase names.

For example, type:

```
sampObj.methods
```

MATLAB displays:

```
Methods for class COM.mwsamp_mwsampctrl_1:
```

AboutBox	GetVariantVector	deleteproperty
Beep	Redraw	events
FireClickEvent	SetBSTR	get
GetBSTR	SetBSTRArray	interfaces

GetBSTRArray	SetI4	invoke
GetI4	SetI4Array	load
GetI4Array	SetI4Vector	move
GetI4Vector	SetR8	propedit
GetIDispatch	SetR8Array	release
GetR8	SetR8Vector	save
GetR8Array	addproperty	send
GetR8Vector	constructorargs	set
GetVariantArray	delete	

Examples of MATLAB COM functions are `addproperty` and `set`. Although the list is sorted alphabetically, uppercase function names are listed first. For example, `Redraw` appears before `get`.

Using methods with -full

When you include the `-full` qualifier in the `methods` function, MATLAB also specifies the input and output arguments for each method. For an overloaded method, the returned array includes a description of each of its signatures.

Type:

```
sampObj.methods('-full')
```

MATLAB displays:

```
Methods for class COM.mwsamp_mwsampctrl_1:
```

```
AboutBox(handle)
Beep(handle)
FireClickEvent(handle)
string GetBSTR(handle)
Variant GetBSTRArray(handle)
int32 GetI4(handle)
Variant GetI4Array(handle)
Variant GetI4Vector(handle)
handle GetIDispatch(handle)
double GetR8(handle)
Variant GetR8Array(handle)
Variant GetR8Vector(handle)
Variant GetVariantArray(handle)
```

```
Variant GetVariantVector(handle)
Redraw(handle)
string SetBSTR(handle, string)
Variant SetBSTRArray(handle, Variant)
int32 SetI4(handle, int32)
Variant SetI4Array(handle, Variant)
Variant SetI4Vector(handle, Variant)
double SetR8(handle, double)
Variant SetR8Array(handle, Variant)
Variant SetR8Vector(handle, Variant)
addproperty(handle, string)
MATLAB array constructorargs(handle)
delete(handle, MATLAB array)
deleteproperty(handle, string)
MATLAB array events(handle, MATLAB array)
MATLAB array get(handle)
MATLAB array get(handle, MATLAB array, MATLAB array)
MATLAB array get(handle vector, MATLAB array, MATLAB array)
MATLAB array interfaces(handle)
MATLAB array invoke(handle)
MATLAB array invoke(handle, string, MATLAB array)
load(handle, string)
MATLAB array move(handle, MATLAB array)
MATLAB array move(handle)
propedit(handle)
release(handle, MATLAB array)
save(handle, string)
MATLAB array send(handle)
MATLAB array set(handle vector, MATLAB array, MATLAB array)
MATLAB array set(handle, MATLAB array, MATLAB array)
MATLAB array set(handle)
```

In the `mwsamp` control, `get` is an overloaded function, and MATLAB displays each of its signatures.

Using `methodsview`

The `methodsview` function opens a new window with an easy-to-read display of all methods supported by the object. It displays the same information as the `handle.methods(' -full')` command.

For example, type:

```
sampObj.methodsview
```

MATLAB opens a window showing (in part):

The screenshot shows a window titled "Methods of class COM.mwsamp_mwsa...". The window contains a table with the following columns: Return Type, Name, Arguments, and Inherited From. The table lists various methods and their signatures.

Return Type	Name	Arguments	Inherited From
	Redraw	(handle)	COM.mwsamp_mwsampctrl_1
string	SetBSTR	(handle, string)	COM.mwsamp_mwsampctrl_1
Variant	SetBSTRArray	(handle, Variant)	COM.mwsamp_mwsampctrl_1
int32	SetI4	(handle, int32)	COM.mwsamp_mwsampctrl_1
Variant	SetI4Array	(handle, Variant)	COM.mwsamp_mwsampctrl_1
Variant	SetI4Vector	(handle, Variant)	COM.mwsamp_mwsampctrl_1
double	SetR8	(handle, double)	COM.mwsamp_mwsampctrl_1
Variant	SetR8Array	(handle, Variant)	COM.mwsamp_mwsampctrl_1
Variant	SetR8Vector	(handle, Variant)	COM.mwsamp_mwsampctrl_1
	addproperty	(handle, string)	COM.mwsamp_mwsampctrl_1
MATLAB array	constructorargs	(handle)	COM.mwsamp_mwsampctrl_1
	delete	(handle, MATLAB array)	COM.mwsamp_mwsampctrl_1
	deleteproperty	(handle, string)	COM.mwsamp_mwsampctrl_1

Invoking Methods on an Object

This section covers the following topics:

- “Calling Syntax” on page 10-34
- “Input and Output Arguments” on page 10-35
- “Example Using mwsamp” on page 10-35

Calling Syntax

To invoke a method on a COM object, use *dot syntax*, also called dot notation. This is a simpler syntax that doesn’t require an explicit function call. For situations where you cannot use this syntax, see “Exceptions to Using Implicit Syntax” on page 10-36.

The format of a dot syntax statement is:

```
outputvalue = object.methodname('arg1', 'arg2', ...);
```

Specify the object name, the dot (`.`), and the name of the function or method. Enclose any input arguments in parentheses after the function name. Specify output arguments to the left of the equal sign.

Dot syntax is a special case of calling by method name. An alternative syntax for calling by method name is:

```
outputvalue = methodname(object, 'arg1', 'arg2', ...);
```

MATLAB also supports the following explicit syntax statements:

```
outputvalue = invoke(object, 'methodname', 'arg1', 'arg2', ...);  
outputvalue = object.invoke('methodname', 'arg1', 'arg2', ...);
```

Input and Output Arguments

The `methodsview` output window and the `methods -full` command show what data types to use for input and output arguments. For information about reading a signature statement and using input and output arguments, see “Handling COM Data in MATLAB Software” on page 10-65.

Example Using `mwsamp`

The following example creates three circles in a MATLAB figure window. It shows different commands you can use to change the circles.

To create the COM objects, type:

```
h1 = actxcontrol('mwsamp.mwsampctrl.2', [0 0 200 200]);  
h2 = actxcontrol('mwsamp.mwsampctrl.2', [200 200 200 200]);  
h3 = actxcontrol('mwsamp.mwsampctrl.2', [400 0 200 200]);
```

You can explicitly change the size of and redraw a circle using the commands:

```
h1.set('Radius', 100);  
invoke(h1, 'Redraw')
```

You can implicitly change the size using:

```
h2.Radius = 50;  
h3.Radius = 25;
```

To redraw the circles using method name syntax, type:

```
Redraw(h2)  
h3.Redraw
```

Close the figure window.

Exceptions to Using Implicit Syntax

You cannot use dot syntax and must explicitly call the `get`, `set`, and `invoke` functions under the following conditions:

- “Accessing Nonpublic Properties and Methods” on page 10-36
- “Accessing Properties That Take Arguments” on page 10-37
- “Operating on a Vector of Objects” on page 10-37

Accessing Nonpublic Properties and Methods

If the property or method you want to access is not a public property or method of the object class, or if it is not in the type library for the control or server, you must call `get`, `set`, or `invoke` explicitly.

If you use a syntax statement of the following format for a nonpublic property *aProperty*:

```
x = handle.aProperty
```

MATLAB displays a message such as:

```
No appropriate method or public field aProperty for class  
COM.aClass.application.
```

Instead, you must use the `get` function explicitly:

```
x = handle.get('aProperty')
```

To find public properties and methods on COM object *h*, type:

```
publicproperties = h.get  
publicmethods = h.invoke
```

Accessing Properties That Take Arguments

Some COM objects have properties that accept input arguments. MATLAB treats these properties like methods. For an example of this feature, see “Properties That Take Arguments” on page 10-25.

To get or set the value of such a property, you must make an explicit call to the `get` or `set` function, as shown in the following example. In this example, `A1` and `B2` are arguments that specify which `Range` interface to return on the `get` operation:

```
eActivesheetRange = e.Activesheet.get('Range', 'A1', 'B2');
```

Operating on a Vector of Objects

If you operate on a vector of objects you must call `get` or `set` explicitly to access properties. For an example, see “Working with Multiple Objects” on page 10-20. This applies only to the `get` and `set` functions. You cannot invoke a method on multiple COM objects, even if you call the `invoke` function explicitly.

Specifying Enumerated Parameters

Enumeration is a way of assigning a descriptive name to a symbolic value.

For example, the input to a function is the atomic number of an element. It is easier to remember an element name than the atomic number. Using enumeration, you can pass the word `'arsenic'` in place of the value 33.

MATLAB supports enumeration for parameters passed to methods under the condition that the type library in use reports the parameter as `ENUM`, and only as `ENUM`.

Note MATLAB does not support enumeration for any parameter that the type library reports as both `ENUM` and `Optional`.

In this example, the `Location` method accepts the enumerated value `'xlLocationAsObject'`.

Create a Microsoft Excel Chart object:

```
e = actxserver('Excel.Application');

% Insert a new workbook.
Workbook = e.Workbooks.Add;
e.Visible = 1;
Sheets = e.ActiveWorkBook.Sheets;

% Get a handle to the active sheet.
Activesheet = e.Activesheet;

%Add a Chart
Charts = Workbook.Charts;
Chart = Charts.Add;
```

To see what type of chart you can create, type:

```
Chart.inspect
```

Scroll through the Property Inspector window to find `ChartType`. Click the drop-down arrow to see all possible `ChartType` values. This is an enumerated list. Close the property inspector.

To programmatically set the `ChartType`, type:

```
% Set chart type to be a line plot.
Chart.ChartType = 'xlXYScatterLines'
C1 = Chart.Location('xlLocationAsObject', 'Sheet1');
```

Close the Excel spreadsheet.

Optional Input Arguments

When calling a method that takes optional input arguments, you can skip any optional argument by specifying an empty array (`[]`) in its place. The syntax for calling a method with second argument `arg2` not specified is:

```
handle.methodname(arg1, [], arg3);
```

The following example uses the `Add` method to add new sheets to an Excel workbook. The `Add` method has the following optional input arguments:

- **Before** — The sheet before which to add the new sheet
- **After** — The sheet after which to add the new sheet
- **Count** — The total number of sheets to add
- **Type** — The type of sheet to add

The following code creates a workbook with the default number of worksheets, and inserts an additional sheet after Sheet 1. To do this, call `Add` with the second argument, `After`. You omit the first argument, `Before`, by using `[]` in its place, as shown in the last line of the example:

```
% Open an Excel Server.
e = actxserver('Excel.Application');

% Insert a new workbook.
e.Workbooks.Add;
e.Visible = 1;

% Get the Active Workbook with three sheets.
eSheets = e.ActiveWorkbook.Sheets;

% Add a new sheet after eSheet1.
eSheet1 = eSheets.Item(1);
eNewSheet = eSheets.Add([], eSheet1);

Close the Excel spreadsheet.
```

Returning Multiple Output Arguments

If you know that a server function supports multiple outputs, you can return any or all of those outputs to a MATLAB client.

The following syntax shows a server function `functionname` called by the MATLAB client. `retval` is the function's first output argument, or return value. The other output arguments are `out1`, `out2`,

```
[retval out1 out2 ...] = handle.functionname(in1, in2, ...);
```

MATLAB makes use of the pass-by-reference capabilities in COM to implement this feature. Note that pass-by-reference is a COM feature; MATLAB does not support pass-by-reference.

Argument Callouts in Error Messages

When a MATLAB client sends a command with an invalid argument to a COM server application, the server sends back an error message, similar to the following, identifying the invalid argument.

```
??? Error: Type mismatch, argument 3.
```

If you do not use the dot syntax format, be careful interpreting the argument number in this type of message.

For example, using dot syntax, if you type:

```
handle.PutFullMatrix('a', 'base', 7, [5 8]);
```

MATLAB displays:

```
??? Error: Type mismatch, argument 3.
```

In this case, the argument, 7, is invalid because `PutFullMatrix` expects the third argument to be an array data type, not a scalar. In this example, the error message identifies 7 as argument 3.

However, if you use the syntax:

```
PutFullMatrix(handle, 'a', 'base', 7, [5 8]);
```

MATLAB displays:

```
??? Error: Type mismatch, argument 3.
```

In this call to the `PutFullMatrix` function, 7 is argument four. However, the COM server does not receive the first argument. The `handle` argument merely identifies the server. It does not get passed to the server. This means the server sees 'a' as the first argument, and the invalid argument, 7, as the third.

If you use the syntax:

```
invoke(handle, 'PutFullMatrix', 'a', 'base', 7, [5 8]);
```

MATLAB again displays:

```
??? Error: Type mismatch, argument 3.
```

As in the previous example, MATLAB uses the `handle` argument to identify the server. The `'PutFullMatrix'` argument is also only used by MATLAB. While the invalid argument is the fifth argument in your MATLAB command, the server still identifies it as argument 3, because the first two arguments are not seen by the server.

Use Events

In this section...

“About Events” on page 10-42

“Functions for Working with Events” on page 10-43

“Examples of Event Handlers” on page 10-43

“Responding to Events — an Overview” on page 10-44

“Responding to Events — Examples” on page 10-46

“Writing Event Handlers” on page 10-54

“Sample Event Handlers” on page 10-57

“Writing Event Handlers as MATLAB Local Functions” on page 10-58

About Events

An *event* is typically a user-initiated action that takes place in a server application, which often requires a reaction from the client. For example, a user clicking the mouse at a particular location in a server interface window might require the client take some action in response. When an event is *fired*, the server communicates this occurrence to the client. If the client is *listening* for this particular type of event, it responds by executing a routine called an *event handler*.

The MATLAB COM client can subscribe to and handle the events fired by a Microsoft ActiveX control or a COM server. Select the events you want the client to listen to by registering each event you want active with the event handler to be used in responding to the event. When a registered event takes place, the control or server notifies the client, which responds by executing the appropriate event handler routine. You can write event handlers as MATLAB functions.

Note MATLAB does not support asynchronous events.

Note MATLAB does not support interface events from a Custom server.

Functions for Working with Events

Use the MATLAB functions in the following table to register and unregister events, to list all events, or to list just registered events for a control or server.

Function	Description
<code>actxcontrol</code>	Create a COM control and optionally register those events you want the client to listen to
<code>eventlisteners</code>	Return a list of events attached to listeners
<code>events</code>	List all events, both registered and unregistered, a control or server can generate
<code>isevent</code>	Determine if an item is an event of a COM object
<code>registerevent</code>	Register an event handler with a control or server event
<code>unregisterallevents</code>	Unregister all events for a control or server
<code>unregisterevent</code>	Unregister an event handler with a control or server event

Event names and event handler names are not case sensitive. You cannot abbreviate them.

Examples of Event Handlers

The following examples use event handlers:

- “Add Grid ActiveX Control in a Figure” on page 9-17
- “Read Excel Spreadsheet Data” on page 9-25

Responding to Events – an Overview

This section describes the basic steps to handle events fired by a COM control or server.

- “Identifying All Events” on page 10-44
- “Registering Those Events You Want to Respond To” on page 10-44
- “Identifying Registered Events” on page 10-45
- “Responding to Events As They Occur” on page 10-45
- “Unregistering Events You No Longer Want to Listen To” on page 10-45

Identifying All Events

Use the `events` function to list all events the control or server can respond to. This function returns a structure array, where each field of the structure is the name of an event handler, and the value of that field contains the signature for the handler routine. To invoke events on an object with handle `h`, type:

```
S = h.events
```

Registering Those Events You Want to Respond To

Use the `registerevent` function to register those server events you want the client to respond to. You can register events as follows:

- If you have one function to handle all server events, register this common event handler using the syntax:

```
h.registerevent('handler');
```

- If you have a separate event handler function for different events, use the syntax:

```
h.registerevent({'event1' 'handler1'; 'event2' 'handler2'; ...});
```

For ActiveX controls, you can register events at the time you create an instance of the control using the `actxcontrol` function.

- To register a common event handler function to respond to all events, use:

```
h = actxcontrol('progid', position, figure, 'handler');
```

- To register a separate function to handle each type of event, use:

```
h = actxcontrol('progid', position, figure, ...  
    {'event1' 'handler1'; 'event2' 'handler2'; ...});
```

The MATLAB client responds only to events you have registered. If you register the same event name to the same callback handler multiple times, MATLAB executes the event only once.

Identifying Registered Events

The `eventlisteners` function lists only currently registered events. This function returns a cell array, with each row representing a registered event and the name of its event handler. For example, to invoke `eventlisteners` on an object with handle `h`, type:

```
C = h.eventlisteners
```

Responding to Events As They Occur

Whenever a control or server fires an event that the client is listening for, the client responds to the event by invoking one or more event handlers that have been registered for that event. You can implement these routines as MATLAB functions. Read more about event handlers in the section on “Writing Event Handlers” on page 10-54.

Unregistering Events You No Longer Want to Listen To

If you have registered events that you now want the client to ignore, you can unregister them at any time using the functions `unregisterevent` and `unregisterallevents` as follows:

- For a server with handle `h`, to unregister all events registered with a common event handling function handler, use:

```
h.unregisterevent('handler');
```

- To unregister individual events `eventN`, each registered with its own event handling function `handlerN`, use:

```
h.unregisterevent({'event1' 'handler1'; 'eventN' 'handlerN'});
```

- To unregister all events from the server regardless of which event handling function they are registered with, use:

```
h.unregisterallevents;
```

Responding to Events — Examples

The following examples show you how to respond to events from different COM objects:

- “Responding to Events from an ActiveX Control” on page 10-46
- “Responding to Events from an Automation Server” on page 10-50
- “Responding to Interface Events from an Automation Server” on page 10-53

Responding to Events from an ActiveX Control

This example describes how to handle events fired by an ActiveX control. It uses a control called `mwsamp2` that ships with MATLAB.

Tasks described in this section are:

- “Creating Event Handler Routines” on page 10-46
- “Creating a Control and Registering Events” on page 10-47
- “Listing Control Events” on page 10-47
- “Responding to Control Events” on page 10-48
- “Unregistering Control Events” on page 10-49
- “Using a Common Event Handling Routine” on page 10-50

Creating Event Handler Routines. You can view the event handler code for the `mwsamp2` control in the section “Sample Event Handlers” on page 10-57. Create the event handler files `myclick.m`, `my2click.m`, and `mymoused.m` and save them on your path, for example, `c:\work`.

Creating a Control and Registering Events. The `actxcontrol` function not only creates the control object, but you can use it to register specific events, as well. The code shown here registers two events (`Click` and `MouseDown`) and two respective handler routines (`myclick` and `mymoused`) with the `mwsamp2` control:

```
f = figure('position', [100 200 200 200]);
obj = actxcontrol('mwsamp.mwsampctrl.2', [0 0 200 200], f, ...
    {'Click' 'myclick'; 'MouseDown' 'mymoused'});
```

If, at some later time, you want to register additional events, use the `registerevent` function. For example:

```
obj.registerevent({'DblClick' 'my2click'});
```

Unregister the `DblClick` event before continuing with the example:

```
obj.unregisterevent({'DblClick' 'my2click'});
```

Listing Control Events. At this point, only the `Click` and `MouseDown` events should be registered. To list all events, whether registered or not, type:

```
objEvents = obj.events
```

MATLAB displays:

```
objEvents =
    Click: 'void Click()'
    DblClick: 'void DblClick()'
    MouseDown: 'void MouseDown(int16 Button, int16 Shift,
        Variant x, Variant y)'
```

Event_Args: [1x101 char]

This function returns a structure array, where each field of the structure is the name of an event handler and the value of that field contains the signature for the handler routine. For example:

```
objEvents.Event_Args
```

MATLAB displays:

```
ans =
```

```
void Event_Args(int16 typeshort, int32 typelong,  
               double typedouble, string typestring, bool typebool)
```

To list only the currently registered events, use the `eventlisteners` function:

```
obj.eventlisteners
```

MATLAB displays:

```
ans =  
    'click'      'myclick'  
    'mousedown' 'mymoused'
```

This function returns a cell array, with each row representing a registered event and the name of its event handler.

Responding to Control Events. When MATLAB creates the `mwsamp2` control, it also displays a figure window showing a label and circle at the center. If you click different positions in this window, you see a report in the MATLAB Command Window of the X and Y position of the mouse.

Each time you press the mouse button, the `MouseDown` event fires, calling the `mymoused` function. This function prints the position values for that event to the Command Window. For example:

```
The X position is:  
ans =  
    [122]  
The Y position is:  
ans =  
    [63]
```

The Click event displays the message:

```
Single click function
```

Double-clicking the mouse does nothing different, since the `Db1Click` event is not registered.

Unregistering Control Events. When you unregister an event, the client discontinues listening for occurrences of that event. When the event fires, the client does not respond. If you unregister the `MouseDown` event, MATLAB no longer reports the X and Y positions. Type:

```
obj.unregisterevent({'MouseDown' 'mymoused'});
```

When you click in the figure window, MATLAB displays:

```
Single click function
```

Now, register the `Db1Click` event, using the `my2click` event handler:

```
obj.registerevent({'Db1Click', 'my2click'});
```

If you call `eventlisteners` again:

```
obj.eventlisteners
```

MATLAB displays:

```
ans =  
    'click'      'myclick'  
    'dblclick'  'my2click'
```

When you double-click the mouse button, MATLAB displays:

```
Single click function  
Double click function
```

An easy way to unregister all events for a control is to use the `unregisterallevents` function.

```
obj.unregisterallevents  
obj.eventlisteners
```

When there are no events registered, `eventlisteners` returns an empty cell array:

```
ans =  
    {}
```

Clicking the mouse in the control window now does nothing since there are no active events.

Using a Common Event Handling Routine. If you have events that are registered with a common event handling routine, such as `sampev.m` used in the following example, you can use `unregisterevent` to unregister all of these events in one operation. This example first registers all events from the server with a common handling routine `sampev.m`. MATLAB now handles any type of event from this server by executing `sampev`:

```
obj.registerevent('sampev');
```

Verify the registration by listing all event listeners for that server:

```
obj.eventlisteners
```

MATLAB displays:

```
ans =  
    'click'          'sampev'  
    'dblclick'      'sampev'  
    'mousedown'    'sampev'
```

Now unregister all events for the server that use the `sampev` event handling routine:

```
obj.unregisterevent('sampev');  
obj.eventlisteners
```

MATLAB displays:

```
ans =  
    {}
```

Close the figure window.

Responding to Events from an Automation Server

This example shows how to handle events fired by an Automation server. It creates a server running the Microsoft Internet Explorer program, registers a common event handler for all events, and then has you fire events by browsing to Web sites.

Tasks described in this section are:

- “Creating an Event Handler” on page 10-51
- “Creating a Server” on page 10-51
- “Listing Server Events” on page 10-51
- “Registering Server Events” on page 10-52
- “Responding to Server Events” on page 10-52
- “Unregistering Server Events” on page 10-52
- “Closing the Application” on page 10-53

Creating an Event Handler. Register all events with the same handler routine, `serverevents`. Create the file `serverevents.m`, inserting the following code. Make sure that the file is in your current folder.

```
function serverevents(varargin)

% Display incoming event name
eventname = varargin{end}

% Display incoming event args
eventargs = varargin{end-1}
```

Creating a Server. Next, at the MATLAB command prompt, type the following commands:

```
% Create a server running Internet Explorer.
browser = actxserver('internetexplorer.application');
% Make the server application visible.
browser.set('Visible', 1);
```

Listing Server Events. Use the `events` function to list all events the server can respond to, and `eventlisteners` to list the registered events:

```
browser.events
```

MATLAB displays event information like:

```
:
```

```
StatusTextChange = void StatusTextChange(string Text)
ProgressChange = void ProgressChange(int32 Progress,int32 ProgressMax)
CommandStateChange = void CommandStateChange(int32 Command,bool Enable)
    :
```

List the registered events:

```
browser.eventlisteners
```

No events are registered at this time, so MATLAB displays:

```
ans =
    {}
```

Registering Server Events. Now use your event handler `serverevents`.

```
browser.registerevent('serverevents');
browser.eventlisteners
```

MATLAB displays:

```
ans =
    :
    'statustextchange'      'serverevents'
    'progresschange'      'serverevents'
    'commandstatechange'  'serverevents'
    :
```

Responding to Server Events. At this point, all events have been registered. If any event fires, the common handler routine defined in `serverevents.m` executes to handle that event. Use the Internet Explorer software to browse your favorite Web site, or enter the following command in the MATLAB Command Window:

```
browser.Navigate2('http://www.mathworks.com');
```

You should see a long series of events displayed in the Command Window.

Unregistering Server Events. Use the `unregisterevent` function to unregister the `progresschange` and `commandstatechange` events:

```
browser.unregisterevent({'progresschange', 'serverevents'; ...
```



```
'commandstatechange', 'serverevents'});
```

To unregister all events for an object, use `unregisterallevents`. The following commands unregister all the events that had been registered, and then registers a single event:

```
browser.unregisterallevents;
browser.registerevent({'TitleChange', 'serverevents'});
```

If you now use the Web browser, MATLAB only responds to the `TitleChange` event.

Closing the Application. Close a server application when you no longer intend to use it. To unregister all events and close the application, type:

```
browser.unregisterallevents;
browser.Quit;
browser.delete;
```

Responding to Interface Events from an Automation Server

This example, demonstrating how to handle a COM interface event, shows how to set up an event in a Microsoft Excel workbook object and how to handle its `BeforeClose` event.

To create the event handler `OnBeforeCloseWorkbook`, create the file `OnBeforeCloseWorkbook.m`, inserting the following code. Make sure that the file is in your current folder:

```
% Event handler for Excel workbook BeforeClose event
function OnBeforeCloseWorkbook(varargin)
    disp('BeforeClose event occurred');
```

When you run the following commands:

```
% Create Excel automation server instance
xl = actxserver('Excel.Application');
% Make it visible
xl.Visible = 1;

% Get collection of workbooks and add a new workbook
```

```
hWbks = xl.Workbooks;  
hWorkbook = hWbks.Add;  
  
% Register OnClose event  
hWorkbook.registerevent({'BeforeClose' @OnBeforeCloseWorkbook});  
  
% Close the workbook. This fires the Close event  
% and calls the OnClose handler  
hWorkbook.Close
```

MATLAB displays:

```
BeforeClose event occurred
```

Writing Event Handlers

This section covers the following topics on writing handler routines to respond to events fired from a COM object:

- “Overview of Event Handling” on page 10-54
- “Arguments Passed to Event Handlers” on page 10-55
- “Event Structure” on page 10-56

Overview of Event Handling

An event is fired when a control or server wants to notify its client that something of interest has occurred. For example, many controls trigger an event when the user clicks somewhere in the interface window of a control. Create and register your own MATLAB functions to respond to events when they occur. These functions are event handlers. You can create one handler function to handle all events or a separate handler for each type of event.

For controls, you can register handler functions either at the time you create an instance of the control (using `actxcontrol`), or at any time afterwards (using `registrevent`).

Both `actxcontrol` and `registrevent` use an event handler argument. The event handler argument can be either the name of a single callback routine or a cell array that associates specific events with their respective event handlers. Strings used in the event handler argument are not case sensitive.

For servers, use `registerevent` to register those events you want the client to listen to. For example, to register the `Click` and `DbClick` events, use:

```
h.registerevent({'click' 'myclick'; 'dblclick' 'my2click'});
```

Use `events` to list all the events a COM object recognizes. For example, to list all events for the `mwsamp2` control, use:

```
f = figure ('position', [100 200 200 200]);
h = actxcontrol ('mwsamp.mwsampctrl.2', [0 0 200 200], f);

h.events
    Click = void Click()
    DbClick = void DbClick()
    MouseDown = void MouseDown(int16 Button, int16 Shift,
        Variant x, Variant y)
```

Arguments Passed to Event Handlers

When a registered event is triggered, the MATLAB software passes information from the event to its handler function, as shown in this table.

Arguments Passed by MATLAB Functions

Arg. No.	Contents	Format
1	Object name	MATLAB COM class
2	Event ID	double
3	Start of Event Argument List	As passed by the control
end-2	End of Event Argument List (Argument N)	As passed by the control
end-1	Event Structure	structure
end	Event Name	char array

When writing an event handler function, use the Event Name argument to identify the source of the event. Get the arguments passed by the control from

the Event Argument List (arguments 3 through end-2). All event handlers must accept a variable number of arguments:

```
function event (varargin)
if (strcmp(varargin{end}, 'MouseDown')) % Check the event name
    x_pos = varargin{5}; % Read 5th Event Argument
    y_pos = varargin{6}; % Read 6th Event Argument
end
```

Note The values passed vary with the particular event and control being used.

Event Structure

The second to last argument passed by MATLAB is the Event Structure, which has the fields shown in the following table.

Fields of the Event Structure

Field Name	Description	Format
Type	Event Name	char array
Source	Control Name	MATLAB COM class
EventID	Event Identifier	double
Event Arg Name 1	Event Arg Value 1	As passed by the control
Event Arg Name 2	Event Arg Value 2	As passed by the control
etc.	Event Arg N	As passed by the control

For example, when the MouseDown event of the mwsamp2 control is triggered, MATLAB passes this Event Structure to the registered event handler:

```
Type: 'MouseDown'
Source: [1x1 COM.mwsamp.mwsampctrl.2]
EventID: -605
Button: 1
Shift: 0
x: 27
```

y: 24

Sample Event Handlers

Specify a single callback, `sampev`:

```
f = figure('position', [100 200 200 200]);
h = actxcontrol('mwsamp.mwsampctrl.2', [0 0 200 200], ...
   (gcf, 'sampev')
h =
    COM.mwsamp.mwsampctrl.2
```

Or specify several events using the cell array format:

```
h = actxcontrol('mwsamp.mwsampctrl.2', [0 0 200 200], f, ...
    {'Click' 'myclick'; 'Db1Click' 'my2click'; ...
    'MouseDown' 'mymoused'});
```

The event handlers, `myclick.m`, `my2click.m`, and `mymoused.m`, are:

```
function myclick(varargin)
disp('Single click function')

function my2click(varargin)
disp('Double click function')

function mymoused(varargin)
disp('You have reached the mouse down function')
disp('The X position is: ')
double(varargin{5})
disp('The Y position is: ')
double(varargin{6})
```

Alternatively, you can use the same event handler for all the events you want to monitor using the cell array pairs. Response time is better than using the callback style.

For example:

```
f = figure('position', [100 200 200 200]);
h = actxcontrol('mwsamp.mwsampctrl.2', ...
[0 0 200 200], f, {'Click' 'allevents'; ...
```

```
'Db1Click' 'allevents'; 'MouseDown' 'allevents'})
```

where `allevents.m` is:

```
function allevents(varargin)
if (strcmp(varargin{end-1}.Type, 'Click'))
    disp ('Single Click Event Fired')
elseif (strcmp(varargin{end-1}.Type, 'Db1Click'))
    disp ('Double Click Event Fired')
elseif (strcmp(varargin{end-1}.Type, 'MouseDown'))
    disp ('Mousedown Event Fired')
end
```

Writing Event Handlers as MATLAB Local Functions

Instead of maintaining a separate function file for every event handler routine you write, you can consolidate routines into a single file using local functions.

This example shows three event handler routines, `myclick`, `my2click`, and `mymoused`, implemented as local functions in the file `mycallbacks.m`. The call to `str2func` converts the input string to a function handle:

```
function a = mycallbacks(str)
a = str2func(str);

function myclick(varargin)
disp('Single click function')

function my2click(varargin)
disp('Double click function')

function mymoused(varargin)
disp('You have reached the mouse down function')
disp('The X position is: ')
double(varargin{5})
disp('The Y position is: ')
double(varargin{6})
```

To register one of these events, call `mycallbacks`, passing the name of the event handler:

```
h = actxcontrol('mwsamp.mwsampctrl.2', [0 0 200 200], ...
```

```
    gcf, 'sampev')  
h.registerevent({'Click', mycallbacks('myclick')});
```

Getting Interfaces to COM Object

In this section...

“IUnknown and IDispatch Interfaces” on page 10-60

“Custom Interfaces” on page 10-61

IUnknown and IDispatch Interfaces

When you invoke the `actxserver` or `actxcontrol` functions, the MATLAB software creates the server and returns a handle to the server interface as a means of accessing its properties and methods. The software uses the following process to determine which handle to return:

- 1 First get a handle to the IUnknown interface from the component. All COM components are required to implement this interface.
- 2 Attempt to get the IDispatch interface. If IDispatch is implemented, return a handle to this interface. If IDispatch is not implemented, return the handle to IUnknown.

Additional Interfaces

Components often provide additional interfaces, based on IDispatch, that are implemented as properties. Like any other property, you obtain these interfaces using the MATLAB `get` function.

For example, a Microsoft Excel component contains numerous interfaces. To list these interfaces, along with Excel properties, type:

```
h = actxserver('Excel.Application');  
h.get
```

MATLAB displays information like:

```
Application: [1x1 Interface.Microsoft_Excel_9.0_
Object_Library._Application]
Creator: 'xlCreatorCode'
Parent: [1x1 Interface.Microsoft_Excel_9.0_
Object_Library._Application]
```



```

ActiveCell: []
ActiveChart: [1x50 char]
          :
          .

```

To see if `Workbooks` is an interface, type:

```
w = h.Workbooks
```

MATLAB displays:

```
w =
    Interface.Microsoft_Excel_9.0_Object_Library.Workbooks
```

The information displayed depends on the version of the Excel software you have on your system.

Custom Interfaces

The MATLAB COM Interface supports custom interfaces for the following client/server configurations:

- “MATLAB Client and In-Process Server” on page 9-33
- “MATLAB Client and Out-of-Process Server” on page 9-34

Limitations to custom interface support are:

- Custom interfaces are not supported on a 64-bit version of MATLAB.
- You cannot invoke functions with optional parameters.

Once you have created a server, you can query the server component to see if any custom interfaces are implemented using the `interfaces` function. `interfaces` returns the names in a cell array of strings.

For example, if you have a component with the ProgID `mytestenv.calculator`, you can see its custom interfaces using the commands:

```
h = actxserver('mytestenv.calculator');
customlist = h.interfaces
```

MATLAB displays the interfaces, which might be:

```
customlist =  
    ICalc1  
    ICalc2  
    ICalc3
```

To get the handle to a particular interface, use the `invoke` function

```
c1 = h.invoke('ICalc1')  
c1 =  
    Interface.Calc_1.0_Type_Library.ICalc_Interface
```

Use this handle `c1` to access the properties and methods of the object through this custom interface `ICalc1`.

For example, to list the properties, use:

```
c1.get  
    background: 'Blue'  
    height: 10  
    width: 0
```

To list the methods, use:

```
c1.invoke  
    Add = double Add(handle, double, double)  
    Divide = double Divide(handle, double, double)  
    Multiply = double Multiply(handle, double, double)  
    Subtract = double Subtract(handle, double, double)
```

To add and multiply numbers using the `Add` and `Multiply` methods of the object, use:

```
sum = c1.Add(4, 7)  
sum =  
    11  
  
prod = c1.Multiply(4, 7)  
prod =  
    28
```

Save COM Objects

In this section...

“Functions for Saving and Restoring COM Objects” on page 10-63

“Releasing COM Interfaces and Objects” on page 10-64

Functions for Saving and Restoring COM Objects

Use these MATLAB functions to save and restore the state of a COM control object.

Function	Description
load	Load and initialize a COM control object from a file
save	Write and serialize a COM control object to a file

Save, or *serialize*, the current state of a COM control to a file using the `save` function. *Serialization* is the process of saving an object onto a storage medium (such as a file or a memory buffer) or transmitting it across a network connection link in binary form.

The following example creates an `mwsamp2` control and saves its original state to the file `mwsample`:

```
f = figure('position', [100 200 200 200]);
h = actxcontrol('mwsamp.mwsampctrl.2', [0 0 200 200], f);
h.save('mwsample')
```

Now, alter the figure by changing its label and the radius of the circle:

```
h.Label = 'Circle';
h.Radius = 50;
h.Redraw;
```

Using the `load` function, you can restore the control to its original state:

```
h.load('mwsample');
```

To verify the results, type:

```
h.get
```

MATLAB displays:

```
ans =  
    Label: 'Label'  
    Radius: 20
```

Note MATLAB supports the COM save and load functions for controls only.

Releasing COM Interfaces and Objects

Use these MATLAB functions to release or delete a COM object or interface.

Function	Description
<code>delete</code>	Delete a COM object or interface
<code>release</code>	Release a COM interface

When you no longer need an interface, use the `release` function to release the interface and reclaim the memory used by it. When you no longer need a control or server, use the `delete` function to delete it. Alternatively, you can use the `delete` function to both release all interfaces for the object and delete the server or control.

Note In versions of MATLAB earlier than 6.5, failure to explicitly release interface handles or delete the control or server often results in a memory leak. This is true even if the variable representing the interface or COM object has been reassigned. In MATLAB version 6.5 and later, the control or server, along with all interfaces to it, is destroyed on reassignment of the variable or when the variable representing a COM object or interface goes out of scope.

When you delete or close a figure window containing a control, MATLAB automatically releases all interfaces for the control. MATLAB also automatically releases all handles for an Automation server when you exit the program.

Handling COM Data in MATLAB Software

In this section...

“Passing Data to COM Objects” on page 10-65

“Handling Data from COM Objects” on page 10-67

“Unsupported Types” on page 10-68

“Passing MATLAB Data to ActiveX Objects” on page 10-69

“Passing MATLAB SAFEARRAY to COM Object” on page 10-69

“Reading SAFEARRAY from COM Objects in MATLAB Applications” on page 10-71

“Displaying MATLAB Syntax for COM Objects” on page 10-72

Passing Data to COM Objects

When you use a COM object in a MATLAB command, the MATLAB types you pass in the call are converted to types native to the COM object. MATLAB performs this conversion on each argument that is passed. This section describes the conversion.

MATLAB arguments are converted by MATLAB into types that best represent the data to the COM object. The following table shows all the MATLAB base types for passed arguments and the COM types defined for input arguments. Each row shows a MATLAB type followed by the possible COM argument matches. For a description of COM variant types, see the table in “Handling Data from COM Objects” on page 10-67.

MATLAB Argument	Closest COM Type	Allowed Types
handle	VT_DISPATCH VT_UNKNOWN	VT_DISPATCH VT_UNKNOWN
string	VT_BSTR	VT_LPWSTR VT_LPSTR VT_BSTR VT_FILETIME VT_ERROR VT_DECIMAL VT_CLSID VT_DATE
int16	VT_I2	VT_I2
uint16	VT_UI2	VT_UI2
int32	VT_I4	VT_I4 VT_INT
uint32	VT_UI4	VT_UI4 VT_UINT
int64	VT_I8	VT_I8
uint64	VT_UI8	VT_UI8
single	VT_R4	VT_R4
double	VT_R8	VT_R8 VT_CY
logical	VT_BOOL	VT_BOOL
char	VT_I1	VT_I1 VT_UI1

Variant Data

variant is any data type except a structure or a sparse array. (For more information, see “Fundamental MATLAB Classes”.)

When used as an input argument, MATLAB treats variant and variant(pointer) the same way.

MATLAB Argument	Closest COM Type	Allowed Types
variant	VT_VARIANT	VT_VARIANT VT_USERDEFINED VT_ARRAY
variant(pointer)	VT_VARIANT	VT_VARIANT VT_BYREF

SAFEARRAY Data

When a COM method identifies a SAFEARRAY or SAFEARRAY(pointer), the MATLAB equivalent is a matrix.

MATLAB Argument	Closest COM Type	Allowed Types
SAFEARRAY	VT_SAFEARRAY	VT_SAFEARRAY
SAFEARRAY(pointer)	VT_SAFEARRAY	VT_SAFEARRAY VT_BYREF

Handling Data from COM Objects

Data returned from a COM object is often incompatible with MATLAB types. When this occurs, MATLAB converts the returned value to a data type native to the MATLAB language. This section describes the conversion performed on the various types that can be returned from COM objects.

The following table shows how MATLAB converts data from a COM object into MATLAB variables.

COM Variant Type	Description	MATLAB Representation
VT_DISPATCH VT_UNKNOWN	IDispatch * IUnknown *	handle
VT_LPWSTR VT_LPSTR VT_BSTR VT_FILETIME VT_ERROR VT_DECIMAL	wide null terminated string null terminated string OLE Automation string FILETIME SCODE	string

COM Variant Type	Description	MATLAB Representation
VT_CLSID VT_DATE	16-byte fixed point Class ID date	
VT_INT VT_UINT VT_I2 VT_UI2 VT_I4 VT_UI4 VT_R4 VT_R8 VT_CY	signed machine int unsigned machine int 2 byte signed int unsigned short 4 byte signed int unsigned long 4 byte real 8 byte real currency	double
VT_I8	signed int64	int64
VT_UI8	unsigned int64	uint64
VT_BOOL		logical
VT_I1 VT_UI1	signed char unsigned char	char
VT_VARIANT VT_USERDEFINED VT_ARRAY	VARIANT * user-defined type SAFEARRAY*	variant
VT_VARIANT VT_BYREF	VARIANT * void* for local use	variant(pointer)
VT_SAFEARRAY	use VT_ARRAY in VARIANT	SAFEARRAY
VT_SAFEARRAY VT_BYREF		SAFEARRAY(pointer)

Unsupported Types

MATLAB does not support the following COM interface types and displays the warning ActiveX - unsupported VARIANT type encountered.

- Structure
- Sparse array
- Multidimensional SAFEARRAYs (greater than two dimensions)
- Write-only properties

Passing MATLAB Data to ActiveX Objects

The tables also show the mapping of MATLAB types to COM types that you must use to pass data from MATLAB to an Microsoft ActiveX object. For all other types, MATLAB displays the warning `ActiveX - invalid argument type or value`.

Passing MATLAB SAFEARRAY to COM Object

The SAFEARRAY data type is a standard way to pass arrays between COM objects. This section explains how MATLAB passes SAFEARRAY data to a COM object.

- “Default Behavior in MATLAB Software” on page 10-69
- “Examples” on page 10-69
- “How to Pass a Single-Dimension SAFEARRAY” on page 10-71
- “Passing SAFEARRAY By Reference” on page 10-71

Default Behavior in MATLAB Software

MATLAB represents an m -by- n matrix as a two-dimensional SAFEARRAY, where the first dimension has m elements and the second dimension has n elements. MATLAB passes the SAFEARRAY by value.

Examples

The following examples use a COM object that expects a SAFEARRAY input parameter.

When MATLAB passes a 1-by-3 array :

```
B = [2 3 4]
B =
```

```
2 3 4
```

the object reads:

```
No. of dimensions: 2
Dim: 1, No. of elements: 1
Dim: 2, No. of elements: 3
Elements:
2.0
3.0
4.0
```

When MATLAB passes a 3-by-1 array:

```
C = [1;2;3]
C =
1
2
3
```

the object reads:

```
No. of dimensions: 2
Dim: 1, No. of elements: 3
Dim: 2, No. of elements: 1
Elements:
1.0
2.0
3.0
```

When MATLAB passes a 2-by-4 array:

```
D = [2 3 4 5;5 6 7 8]
D =
2 3 4 5
5 6 7 8
```

the object reads:

```
No. of dimensions: 2
```

```

Dim: 1,   No. of elements: 2
Dim: 2,   No. of elements: 4
Elements:
    2.0
    3.0
    4.0
    5.0
    5.0
    6.0
    7.0
    8.0

```

How to Pass a Single-Dimension SAFEARRAY

For information about passing arguments as one-dimensional arrays to a COM object, see the Technical Support solution 1-SKYP9.

Passing SAFEARRAY By Reference

For information about passing arguments by reference to a COM object, see the Technical Support solution 1-SKYPY.

Reading SAFEARRAY from COM Objects in MATLAB Applications

This section explains how MATLAB reads SAFEARRAY data from a COM object.

MATLAB reads a one dimensional SAFEARRAY with *n* elements from a COM object as a 1-by-*n* matrix. For example, using methods from the MATLAB sample control `mwsamp`, type:

```

h=actxcontrol('mwsamp.mwsampctrl1.1')
a = h.GetI4Vector

```

MATLAB displays:

```

a =
     1     2     3

```

MATLAB reads a two-dimensional SAFEARRAY with *n* elements as a 2-by-*n* matrix. For example:

```
a = h.GetR8Array
```

MATLAB displays:

```
a =  
    1    2    3  
    4    5    6
```

MATLAB reads a three-dimensional SAFEARRAY with two elements as a 2-by-2-by-2 cell array. For example:

```
a = h.GetBSTRArray
```

MATLAB displays:

```
a(:, :, 1) =  
  
    '1 1 1'    '1 2 1'  
    '2 1 1'    '2 2 1'  
  
a(:, :, 2) =  
  
    '1 1 2'    '1 2 2'  
    '2 1 2'    '2 2 2'
```

Displaying MATLAB Syntax for COM Objects

To determine which MATLAB types to use when passing arguments to COM objects, use the `invoke` or `methodsviw` functions. These functions list all the methods found in an object, along with a specification of the types required for each argument.

In the following example, a server called `MyApp` has a method `TestMeth1` with the following syntax:

```
HRESULT TestMeth1 ([out, retval] double* dret);
```

This method has no input argument, and it returns a variable of type `double`. To display the MATLAB syntax for calling the method, type:

```
h = actxserver('MyApp');  
h.invoke
```

MATLAB displays:

```
ans =  
    TestMeth1 = double TestMeth1 (handle)
```

The signature of TestMeth1 is:

```
double TestMeth1(handle)
```

MATLAB requires you to use an object handle as an input argument for every method, in addition to any input arguments required by the method itself.

Using the variable `var`, which is of type `double`, type:

```
var = h.TestMeth1;
```

or:

```
var = TestMeth1(h);
```

While the following syntax is correct, its use is discouraged:

```
var = invoke(h,'TestMeth1');
```

Now consider the server called `MyApp1` with the following methods:

```
HRESULT TestMeth1 ([out, retval] double* dret);  
HRESULT TestMeth2 ([in] double* d, [out, retval] double* dret);  
HRESULT TestMeth3 ([out] BSTR* sout,  
                  [in, out] double* dinout,  
                  [in, out] BSTR* sinout,  
                  [in] short sh,  
                  [out] long* ln,  
                  [in, out] float* b1,  
                  [out, retval] double* dret);
```

Type the commands:

```
h = actxserver('MyApp1');
```

```
h.invoke
```

MATLAB displays the list of methods:

```
ans =  
  TestMeth1 = double TestMeth1 (handle)  
  TestMeth2 = double TestMeth2 (handle, double)  
  TestMeth3 = [double, string, double, string, int32, single] ...  
              TestMeth3(handle, double, string, int16, single)
```

`TestMeth2` requires an input argument `d` of type `double`, as well as returning a variable `dret` of type `double`. Some examples of calling `TestMeth2` are:

```
var = h.TestMeth2(5);
```

or:

```
var = TestMeth2(h, 5);
```

`TestMeth3` requires multiple input arguments, as indicated within the parentheses on the right side of the equals sign, and returns multiple output arguments, as indicated within the brackets on the left side of the equals sign.

```
[double, string, double, string, int32, single] %output arguments  
TestMeth3(handle, double, string, int16, single) %input arguments
```

The first input argument is the required `handle`, followed by four input arguments.

```
TestMeth3(handle, in1, in2, in3, in4)
```

The first output argument is the return value `retval`, followed by five output arguments.

```
[retval, out1, out2, out3, out4, out5]
```

This is how the arguments map into a MATLAB command:

```
[dret, sout, dinout, sinout, ln, b1] = TestMeth3(handle, ...  
                                             dinout, sinout, sh, b1)
```

where `dret` is `double`, `sout` is `string`, `dinout` is `double` and is both an input and an output argument, `sinout` is `string` (input and output argument), `ln` is `int32`, `b1` is `single` (input and output argument), `handle` is the handle to the object, and `sh` is `int16`.

Use MATLAB Application as Automation Client

In this section...

“MATLAB Sample Control” on page 10-76

“Using a MATLAB Application as an Automation Client” on page 10-76

“Connecting to an Existing Excel Application” on page 10-78

“Running a Macro in an Excel Server Application” on page 10-79

“MATLAB COM Client Example” on page 10-80

MATLAB Sample Control

MATLAB software ships with a simple example COM control that draws a circle on the screen, displays some text, and fires events when the user single- or double-clicks the control. Create the control by running the `mwsamp.m` file in the `matlabroot\toolbox\matlab\winfun` folder, or type:

```
h = actxcontrol('mwsamp.mwsampctrl.2', [0 0 300 300]);
```

This control is in the same folder, with the control's *type library*. The type library is a binary file used by COM tools to decipher the control's capabilities. For other examples using the `mwsamp2` control, see “Writing Event Handlers” on page 10-54.

Using a MATLAB Application as an Automation Client

This example uses MATLAB software as an Automation client and the Microsoft Excel spreadsheet program as the server. It provides a good overview of typical functions. In addition, it is a good example of using the Automation interface of another application:

```
% MATLAB Automation client example
%
% Open Excel, add workbook, change active worksheet,
% get/put array, save.

% First, open an Excel Server.
e = actxserver('Excel.Application');
```



```
% Insert a new workbook.
eWorkbook = e.Workbooks.Add;
e.Visible = 1;

% Make the first sheet active.
eSheets = e.ActiveWorkbook.Sheets;

eSheet1 = eSheets.get('Item', 1);
eSheet1.Activate;

% Put a MATLAB array into Excel.
A = [1 2; 3 4];
eActivesheetRange = e.Activesheet.get('Range', 'A1:B2');
eActivesheetRange.Value = A;

% Get back a range.
% It will be a cell array, since the cell range
% can contain different types of data.
eRange = e.Activesheet.get('Range', 'A1:B2');
B = eRange.Value;

% Convert to a double matrix. The cell array must contain only
% scalars.
B = reshape([B{:}], size(B));

% Now, save the workbook.
eWorkbook.SaveAs('myfile.xls');

% Avoid saving the workbook and being prompted to do so
eWorkbook.Saved = 1;
eWorkbook.Close;

% Quit Excel and delete the server.
e.Quit;
e.delete;
```

Note Make sure that you always close any workbook objects you create. This can prevent potential memory leaks.

Connecting to an Existing Excel Application

You can give MATLAB access to a file that is open by another application by creating a new COM server from the MATLAB client, and then opening the file through this server. This example shows how to do this for an Excel application that has a file `weekly_log.xls` open:

```
excelapp = actxserver('Excel.Application');
wkbk = excelapp.Workbooks;
wdata = wkbk.Open('d:\weatherlog\weekly_log.xls');
```

To see what methods are available, type:

```
wdata.methods
Methods for class Interface.Microsoft_Excel_10.0_
Object_Library._Workbook:
```

AcceptAllChanges	LinkInfo	ReloadAs
Activate	LinkSources	RemoveUser
:	:	:
:	:	:

Access data from the spreadsheet by selecting a particular sheet (called 'Week 12' in the example), selecting the range of values (the rectangular area defined by D1 and F6 here), and then reading from this range:

```
sheets = wdata.Sheets;
sheet12 = sheets.Item('Week 12');
range = sheet12.get('Range', 'D1', 'F6');
range.value

ans =
    'Temp.'    'Heat Index'    'Wind Chill'
    [78.4200]  [    32]        [    37]
    [69.7300]  [    27]        [    30]
    [77.6500]  [    17]        [    16]
    [74.2500]  [    -5]        [     0]
    [68.1900]  [    22]        [    35]

wkbk.Close;
excelapp.Quit;
```

Running a Macro in an Excel Server Application

In the following example, MATLAB runs the Microsoft Excel spreadsheet program in a COM server and invokes a macro that has been defined within the active Excel spreadsheet file. The macro, `init_last`, takes no input parameters and is called from the MATLAB client using the statement:

```
handle.ExecuteExcel4Macro('!macroname()');
```

Start the example by opening the spreadsheet file and recording a macro. The macro used here simply sets all items in the last column to zero. Save your changes to the spreadsheet.

Next, in MATLAB, create a COM server running an Excel application, and open the spreadsheet:

```
h = actxserver('Excel.Application');
wkbk = h.Workbooks;
file = wkbk.Open('d:\weatherlog\weekly.xls');
```

Open the sheet that you want to change, and retrieve the current values in the range of interest:

```
sheets = file.Sheets;
sheet12 = sheets.Item('Week 12');
range = sheet12.get('Range', 'D1', 'F5');
range.Value
ans =
    [    78]    [    32]    [    37]
    [    69]    [    27]    [    30]
    [    77]    [    17]    [    16]
    [    74]    [    -5]    [    -1]
    [    68]    [    22]    [    35]
```

Now execute the macro, and verify that the values have changed as expected:

```
h.ExecuteExcel4Macro('!init_last()');
range.Value
ans =
    [    78]    [    32]    [     0]
    [    69]    [    27]    [     0]
    [    77]    [    17]    [     0]
```

```
[ 74] [ -5] [ 0]
[ 68] [ 22] [ 0]
```

MATLAB COM Client Example

MATLAB includes an example, Programming with COM, that illustrate the use of the COM Client with MATLAB.

Deploy ActiveX Controls Requiring Run-Time Licenses

In this section...

“Create a Function to Build the Control” on page 10-81

“Build the Control and the License File” on page 10-81

“Build the Executable” on page 10-82

“Deploy the Files” on page 10-82

When you deploy a Microsoft ActiveX control that requires a run-time license, you must include a license key, which the control reads at run-time. If the key matches the control’s own version of the license key, an instance of the control is created. Use the following procedure to deploy a run-time-licensed control with a MATLAB application.

Create a Function to Build the Control

First, create a function to build the control and save it as a `.m` file. The file must contain two elements:

- The pragma `%%function actxlicense`. This pragma causes the MATLAB Compiler to embed a function named `actxlicense` into the standalone executable file you build.
- A call to `actxcontrol` to create an instance of the control.

Place this file in a folder outside of the MATLAB code tree.

Here is an example file:

```
function buildcontrol
%%function actxlicense
h=actxcontrol('MFCCONTROL2.MFCControl2Ctrl.1',[10 10 200 200]);
```

Build the Control and the License File

Change to the folder where you placed the function you created to build the control. Call the function. When it executes this function, MATLAB determines whether the control requires a run-time license. If it does, MATLAB creates another file, named `actxlicense.m`, in the current working

folder. The `actxlicense` function defined in this file provides the license key to MATLAB at run-time.

Build the Executable

Next, call MATLAB Compiler to create the standalone executable from the file you created to build the control. The executable contains both the function that builds the control and the `actxlicense` function.

```
mcc -m buildcontrol
```

Deploy the Files

Finally, distribute `buildcontrol.exe`, `buildcontrol.ctf`, and the control (`.ocx` or `.dll`).

Use Microsoft Forms 2.0 Controls

In this section...
“Affected Controls” on page 10-83
“Replacement Controls” on page 10-83

You might encounter problems when creating or using Microsoft Forms 2.0 controls in MATLAB. Forms 2.0 controls are designed for use with applications enabled by Microsoft Visual Basic for Applications (VBA). An example is Microsoft Office software.

To work around these problems, use the following replacement controls, or consult article 236458 in the Microsoft Knowledge Base for further information:

<http://support.microsoft.com/default.aspx?kbid=236458>

Affected Controls

You might see this behavior with any of the following Forms 2.0 controls:

- Forms.TextBox.1
- Forms.CheckBox.1
- Forms.CommandButton.1
- Forms.Image.1
- Forms.OptionButton.1
- Forms.ScrollBar.1
- Forms.SpinButton.1
- Forms.TabStrip.1
- Forms.ToggleButton.1

Replacement Controls

Microsoft recommends the following replacements:

Old	New
Forms.TextBox.1	RICHTEXT.RichtextCtrl.1
Forms.CheckBox.1	vidtc3.Checkbox
Forms.CommandButton.1	MSComCtl2.FlatScrollBar.2
Forms.TabStrip.1	COMCTL.TabStrip.1

Use COM Collections

COM *collections* are a way to support groups of related COM objects that can be iterated over. A collection is itself a special interface with a `Count` property (read only), which contains the number of items in the collection, and an `Item` method, which allows you to retrieve a single item from the collection.

The `Item` method is indexed, which means that it requires an argument that specifies which item in the collection is being requested. The data type of the index can be any data type that is appropriate for the particular collection and is specific to the control or server that supports the collection. Although integer indices are common, the index could just as easily be a string value. Often, the return value from the `Item` method is itself an interface. Like all interfaces, release this interface when you are finished with it.

This example iterates through the members of a collection. Each member of the collection is itself an interface (called `Plot` and represented by a MATLAB COM object called `hPlot`.) In particular, this example iterates through a collection of `Plot` interfaces, invokes the `Redraw` method for each interface, and then releases each interface:

```
hCollection = hControl.Plots;
for i = 1:hCollection.Count
    hPlot = hCollection.invoke('Item', i);
    hPlot.Redraw;
    hPlot.release;
end;
hCollection.release;
```

Use MATLAB Application as DCOM Client

Distributed Component Object Model (DCOM) is a protocol that allows clients to use remote COM objects over a network. Additionally, MATLAB can be used as a DCOM client with remote Automation servers if the operating system on which MATLAB is running is DCOM enabled.

Note If you use MATLAB as a remote DCOM server, all MATLAB windows appears on the remote machine.

MATLAB COM Support Limitations

Limitations of MATLAB COM support are:

- MATLAB only supports indexed collections.
- COM controls are not printed with figure windows.
- “Unsupported Types” on page 10-68
- MATLAB does not support asynchronous events.
- A MATLAB COM ActiveX control container does not in-place activate controls until they are visible.

MATLAB COM Automation Server Support

- “MATLAB COM Automation Server Interface” on page 11-2
- “MATLAB Automation Server Functions and Properties” on page 11-7
- “Using MATLAB Application as DCOM Server” on page 11-13
- “Using VT_DATE Data Type” on page 11-14
- “Specifying Shared or Dedicated Server” on page 11-15
- “Manually Create Automation Server” on page 11-16
- “Launch MATLAB as Automation Server in Desktop Mode” on page 11-17
- “Call MATLAB Function from Visual Basic .NET Client” on page 11-18
- “Call MATLAB Function from Web Application” on page 11-19
- “Call MATLAB Function from C# Client” on page 11-22
- “View MATLAB Functions from Visual Basic .NET Object Browser” on page 11-24

MATLAB COM Automation Server Interface

In this section...

“What Is Automation?” on page 11-2

“Creating the MATLAB Server” on page 11-2

“Connecting to an Existing MATLAB Server” on page 11-5

What Is Automation?

Automation is a COM protocol that allows one application (the *controller* or *client*) to control objects exported by another application (the *server*). MATLAB software on Microsoft Windows operating systems supports COM Automation server capabilities. Any Windows program that can be configured as an Automation controller can control MATLAB. Some examples of applications that can be Automation controllers are Microsoft Excel, Microsoft Access, and Microsoft Project applications, and many Microsoft Visual Basic and Microsoft Visual C++ programs.

Note If you plan to build your client application using C/C++, or Fortran, we recommend you use MATLAB Engine instead of an Automation server.

Creating the MATLAB Server

To create a server, you need a programmatic identifier (ProgID) to identify the server. The ProgID for MATLAB is `matlab.application`. For other MATLAB ProgIDs, see “Programmatic Identifiers” on page 9-4.

How you create an Automation server depends on the controller you are using. Consult your controller’s documentation for this information.

If your controller is a MATLAB application and your server is another MATLAB application, you create the Automation server using the `actxserver` function:

```
h = actxserver('matlab.application')
h =
    COM.matlab.application
```

This command automatically creates the Automation server. You can also create the server manually. See “Manually Create Automation Server” on page 11-16.

- “Using MATLAB Software as a Shared or Dedicated Server” on page 11-3
- “Accessing Your Server from the Startup Folder” on page 11-3
- “Get the Status of a MATLAB Automation Server” on page 11-4
- “Creating a MATLAB Automation Server from Visual Basic .NET Application” on page 11-4

Using MATLAB Software as a Shared or Dedicated Server

The MATLAB Automation server has two modes:

- Shared — One or more client applications connect to the same MATLAB server. All clients share the same server.
- Dedicated — Each client application creates its own dedicated MATLAB server.

If you use `matlab.application` as your ProgID, MATLAB creates a shared server. For more information, see “Specifying Shared or Dedicated Server” on page 11-15.

Accessing Your Server from the Startup Folder

The MATLAB Automation server starts up in the `matlabroot\bin\win32` folder. If this is not the MATLAB startup folder, the newly created server does not run the MATLAB startup file (`startup.m`) and does not have access to files in that folder.

To access files in the startup folder, do one of the following:

- Set the server’s working folder to the startup folder (using the `cd` function) and add the startup folder to the server’s MATLAB path (using the `addpath` function).
- Include the path name to the startup folder when referencing those files.

Get the Status of a MATLAB Automation Server

Use the `enableservice` function to determine the current state of a MATLAB Automation server. The function returns a logical value, where logical 1 (`true`) means MATLAB is an Automation server and logical 0 (`false`) means MATLAB is not an Automation server.

For example, if you type:

```
enableservice('AutomationServer')
```

and MATLAB displays:

```
ans =  
     1
```

then MATLAB is currently an Automation server.

Creating a MATLAB Automation Server from Visual Basic .NET Application

If you use a Visual Basic client application to access a MATLAB Automation server, you have two options for creating the server:

- “Accessing Methods from the Visual Basic Object Browser” on page 11-4
- “Using `CreateObject`” on page 11-5

Accessing Methods from the Visual Basic Object Browser. You can use the Object Browser of your Visual Basic client application to see what methods are available from a MATLAB Automation server. To do this you need to reference the MATLAB *type library* in your Visual Basic project.

To set up your Visual Basic project:

- 1** Select the **Project** menu.
- 2** Select **Reference** from the subsequent menu.
- 3** Check the box next to the **MATLAB Application Type Library**.
- 4** Click **OK**.

In your Visual Basic code, use the `New` method to create the server:

```
Matlab = New MApp.MApp
```

View MATLAB Automation methods from the Visual Basic Object Browser under the Library called `MLAPP`.

Using CreateObject. To use the Visual Basic `CreateObject` method, type:

```
MatLab = CreateObject("Matlab.Application")
```

Connecting to an Existing MATLAB Server

It is not always necessary to create a new instance of a MATLAB server whenever your application needs some task done in MATLAB. Clients can connect to an existing MATLAB Automation server using the `actxGetRunningServer` function or by using a command similar to the Visual Basic `.NET GetObject` command.

Using Visual Basic .NET Code

The Visual Basic `.NET` command shown here returns a handle `h` to the MATLAB server application:

```
h = GetObject(, "matlab.application")
```

Note It is important to use the syntax shown above to connect to an existing MATLAB Automation server. Omit the first argument, and make sure the second argument is as shown.

The following Visual Basic `.NET` example connects to an existing MATLAB server, then executes a plot command in the server. If you do not already have a MATLAB server running, create one following the instructions in “Creating a MATLAB Automation Server from Visual Basic `.NET` Application” on page 11-4.

```
Dim h As Object  
h = GetObject(, "matlab.application")  
  
' Handle h should be valid now.
```

```
' Test it by calling Execute.  
h.Execute ("plot([0 18], [7 23])")
```

MATLAB Automation Server Functions and Properties

MATLAB functions and properties enable an Automation controller to manipulate data in the MATLAB workspace. MATLAB can be both a controller and a server. The examples in this section use MATLAB as the client application.

This section explains how to call functions in the MATLAB Automation server and how to use properties that affect the server. These are shown in the following tables and are described in individual function reference pages.

In this section...
“Executing Commands in the MATLAB Server” on page 11-7
“Exchanging Data with the Server” on page 11-9
“Controlling the Server Window” on page 11-10
“Terminating the Server Process” on page 11-10
“Client-Specific Information” on page 11-11
“Using the Visible Property” on page 11-11

Executing Commands in the MATLAB Server

The client program can execute commands in the MATLAB server using these functions.

Function	Description
Execute	Execute MATLAB command in server
Feval	Evaluate MATLAB command in server

Using Execute

Use the Execute function when you want the MATLAB server to execute a command that can be expressed in a single string. For example:

```
h = actxserver('matlab.application');
h.PutWorkspaceData('A', 'base', rand(6))
```

```
h.Execute('A(4:6,:) = []'); % remove rows 4-6
B = h.GetWorkspaceData('A', 'base')
```

MATLAB displays:

```
B =
    0.6208    0.2344    0.6273    0.3716    0.7764    0.7036
    0.7313    0.5488    0.6991    0.4253    0.4893    0.4850
    0.1939    0.9316    0.3972    0.5947    0.1859    0.1146
```

If there is an error, the `Execute` function returns the MATLAB error message with the characters `???` prepended to the text.

Using Feval

Use the `Feval` function when you want the server to execute commands that you cannot express in a single string. The following example uses variables defined in the client, `rows` and `cols`, to modify the server.

This is a continuation of the previous example:

```
rows = 6; cols = 3;
h.Feval('reshape', 0, 'A=', rows, cols);
```

MATLAB interprets `A` in the expression `'A='` as a server variable name.

The `reshape` function in the previous statement does not make an assignment to the server variable `A`; it is equivalent to the following MATLAB statement:

```
reshape(A,6,3)
```

which returns a result, but does not assign the new array. If you get the variable `A` from the server, it is unchanged:

```
B = h.GetWorkspaceData('A', 'base')
```

MATLAB displays:

```
B =
    0.6208    0.2344    0.6273    0.3716    0.7764    0.7036
    0.7313    0.5488    0.6991    0.4253    0.4893    0.4850
```

```
0.1939    0.9316    0.3972    0.5947    0.1859    0.1146
```

Use the `Feval` function return value to get the result of this type of operation. For example, the following statement reshapes the server-side array `A` and returns the result of this operation in the client-side variable `a`:

```
a = h.Feval('reshape', 1, 'A=', rows, cols);
```

The `Feval` function returns a cell array. To view the contents, type:

```
a{:}
```

MATLAB displays:

```
ans =
    0.6208    0.6273    0.7764
    0.7313    0.6991    0.4893
    0.1939    0.3972    0.1859
    0.2344    0.3716    0.7036
    0.5488    0.4253    0.4850
    0.9316    0.5947    0.1146
```

Exchanging Data with the Server

MATLAB provides functions to read and write data to any workspace of a MATLAB server. In these commands, pass the name of the variable to read or write, and the name of the workspace holding that data.

Function	Description
<code>GetCharArray</code>	Get character array from server
<code>GetFullMatrix</code>	Get matrix from server
<code>GetWorkspaceData</code>	Get any type of data from server
<code>PutCharArray</code>	Store character array in server
<code>PutFullMatrix</code>	Store matrix in server
<code>PutWorkspaceData</code>	Store any type of data in server

The `Get/PutCharArray` functions read and write string values to the MATLAB server.

The `Get/PutFullMatrix` functions pass data as a `SAFEARRAY` data type. You can use these functions with any client that supports the `SAFEARRAY` type. This includes MATLAB and Visual Basic clients.

The `Get/PutWorkspaceData` functions pass data as a `variant` data type. Use these functions with any client that supports the `variant` type. These functions are especially useful for VBScript clients because VBScript does not support the `SAFEARRAY` data type.

In this example, write a string to variable `str` in the base workspace of the MATLAB server and read it back to the client:

```
h = actxserver('matlab.application');
h.PutCharArray('str', 'base', ...
    'He jests at scars that never felt a wound.');
```

```
S = h.GetCharArray('str', 'base')
S =
    He jests at scars that never felt a wound.
```

Controlling the Server Window

These functions enable you to make the server window visible or to minimize it.

Function	Description
<code>MaximizeCommandWindow</code>	Display server window on Windows desktop
<code>MinimizeCommandWindow</code>	Minimize size of server window

In this example, create a COM server running MATLAB and minimize it:

```
h = actxserver('matlab.application');
h.MinimizeCommandWindow;
```

Terminating the Server Process

When you are finished with the MATLAB server, quit the MATLAB session.

Function	Description
<code>Quit</code>	Quit the MATLAB session

To quit MATLAB, type:

```
h.Quit;
```

Client-Specific Information

This section provides information specific to MATLAB and Visual Basic .NET clients only.

For MATLAB Clients

To see a summary of all functions along with the required syntax, use the `invoke` function as follows:

```
handle = actxserver('matlab.application');  
handle.invoke
```

For Visual Basic .NET Clients

Data types for the arguments and return values of the server functions are expressed as Automation data types, which are language-independent types defined by the Automation protocol.

For example, `BSTR` is a wide-character string type defined as an Automation type, and is the same data format used by the Visual Basic language to store strings. Any COM-compliant controller should support these data types, although the details of how you declare and manipulate these are controller specific.

Using the Visible Property

You have the option of making MATLAB visible or not by setting the `Visible` property. When visible, MATLAB appears on the desktop, enabling the user to interact with it. This might be useful for such purposes as debugging. When not visible, the MATLAB window does not appear, thus perhaps making for a cleaner interface and also preventing any interaction with the application.

By default, the `Visible` property is enabled, or set to 1:

```
h = actxserver('matlab.application');  
h.Visible  
ans =
```

1

You can change the `Visible` property by setting it to 0 (invisible) or 1 (visible). The following command removes the server application window from the desktop:

```
h.Visible = 0;  
h.Visible  
ans =  
    0
```

Using MATLAB Application as DCOM Server

Distributed Component Object Model (DCOM) is a protocol that allows COM connections to be established over a network. If you are using a version of the Windows operating system that supports DCOM and a controller that supports DCOM, you can use the controller to start a MATLAB server on a remote machine.

To do this, DCOM must be configured properly, and MATLAB must be installed on each machine that is used as a client or server. (Even though the client machine may not be running MATLAB in such a configuration, the client machine must have a MATLAB installation because certain MATLAB components are required to establish the remote connection.) Consult the DCOM documentation for how to configure DCOM for your environment.

Using VT_DATE Data Type

To pass a VT_DATE type input to a Visual Basic program or an ActiveX control method, use the MATLAB class `COM.date`. For example:

```
d = COM.date(2005,12,21,15,30,05);  
get(d)  
    Value: 7.3267e+005  
    String: '12/21/2005 3:30:05 PM'
```

Use the `now` function to set the `Value` property to a date number:

```
d.Value = now;
```

Specifying Shared or Dedicated Server

You can start the MATLAB Automation server in one of two modes – shared or dedicated. A dedicated server is dedicated to a single client; a shared server is shared by multiple clients. The mode is determined by the programmatic identifier (ProgID) used by the client to start MATLAB.

Starting a Shared Server

The ProgID, `matlab.application`, specifies the default mode, which is shared. You can also use the version-specific ProgID, `matlab.application.N.M`, where *N* is the major version and *M* is the minor version of your MATLAB. For example, use *N* = 7 and *M* = 4 for MATLAB version 7.4.

Once MATLAB is started as a shared server, all clients that request a connection to MATLAB using the shared server ProgID connect to the already running instance of MATLAB. In other words, there is never more than one instance of a shared server running, since it is shared by all clients that use the shared server ProgID.

Starting a Dedicated Server

To specify a dedicated server, use the ProgID, `matlab.application.single`, (or the version-specific ProgID, `matlab.application.single.N.M`).

Each client that requests a connection to MATLAB using a dedicated ProgID creates a separate instance of MATLAB; it also requests the server not be shared with any other client. Therefore, there can be several instances of a dedicated server running simultaneously, since the dedicated server is not shared by multiple clients.

Manually Create Automation Server

Microsoft Windows operating system automatically creates an Automation server when a controller application first establishes a server connection. Alternatively, you can manually create the server prior to starting any of the client processes.

To manually create a MATLAB server, use the `/Automation` switch in the MATLAB startup command. You can do this from the DOS command line by typing:

```
matlab /Automation
```

Alternatively, you can add this switch every time you run MATLAB, as follows:

- 1 Right-click the MATLAB shortcut icon



and select **Properties** from the context menu. The Properties dialog box for `matlab.exe` opens to the **Shortcut** tab.

- 2 In the **Target** field, add `/Automation` to the end of the target path for `matlab.exe`. Be sure to include a space between the file name and the symbol `/`. For example:

```
"C:\Program Files\MATLAB\R2006a\bin\win32\MATLAB.exe /Automation"
```

Note When the operating system automatically creates a MATLAB server, it too uses the `/Automation` switch. In this way, MATLAB servers are differentiated from other MATLAB sessions. This protects controllers from interfering with any interactive MATLAB sessions that may be running.

Launch MATLAB as Automation Server in Desktop Mode

To launch MATLAB as a COM Automation server in full desktop mode, use the programmatic identifier `Matlab.Desktop.Application`. For example, type:

```
h = actxserver('Matlab.Desktop.Application')
```

An example in Microsoft Visual Basic is:

```
Dim MatLab As Object  
Dim Result As String  
MatLab = CreateObject("Matlab.Desktop.Application")  
Result = MatLab.Execute("surf(peaks)")
```

Call MATLAB Function from Visual Basic .NET Client

This example calls a user-defined MATLAB function named `solve_bvp` from a Microsoft Visual Basic client application through a COM interface. It also plots a graph in a new MATLAB window and performs a simple computation:

```
Dim MatLab As Object
Dim Result As String
Dim MReal(1, 3) As Double
Dim MImag(1, 3) As Double

MatLab = CreateObject("Matlab.Application")

'Calling MATLAB function from VB
'Assuming solve_bvp exists at specified location
Result = MatLab.Execute("cd d:\matlab\work\bvp")
Result = MatLab.Execute("solve_bvp")

'Executing other MATLAB commands
Result = MatLab.Execute("surf(peaks)")
Result = MatLab.Execute("a = [1 2 3 4; 5 6 7 8]")
Result = MatLab.Execute("b = a + a ")
'Bring matrix b into VB program
MatLab.GetFullMatrix("b", "base", MReal, MImag)
```

Call MATLAB Function from Web Application

This example shows you how to create a Web page that uses a MATLAB application as an Automation server. Run this example from a local system; you cannot deploy it from a Web server. For another example using ASP.NET, see Technical Support solution 1 3JJZWN.

You can invoke MATLAB as an Automation server from any language that supports COM, so for Web applications, you can use VBScript and JavaScript. While this example is simple, it illustrates techniques for passing commands to MATLAB and writing data to and retrieving data from the MATLAB workspace. See “Exchanging Data with the Server” on page 11-9 for related functions.

VBScript and HTML forms are combined in this example to create an interface that enables the user to select a MATLAB plot type from a pull-down menu, click a button, and create the plot in a MATLAB figure window. To accomplish this, the HTML file contains code that:

- Starts MATLAB as an Automation server via a VBScript.
- When users click a button on the HTML page, a VBScript executes that:
 - 1 Determines the type of plot selected.
 - 2 Forms a command string to create the type of plot selected.
 - 3 Forms a string describing the type of plot selected, which passes to the MATLAB base workspace in a variable.
 - 4 Executes the MATLAB command.
 - 5 Retrieves the descriptive string from the MATLAB workspace.
 - 6 Updates the text box on the HTML page.

Here is the HTML used to create this example:

```
<HTML>
<HEAD>
<TITLE>Example of calling MATLAB from VBScript</TITLE>
</HEAD>
<BODY>
```

```

<FONT FACE = "Arial, Helvetica, Geneva" SIZE = "+1" COLOR = "maroon">
Example of calling MATLAB from VBScript
</FONT>
<FONT FACE = "Arial, Helvetica, Geneva" SIZE = "-1">

<!-- %%%%%%%%%%%%%% BEGIN SCRIPT %%%%%%%%%%%%%% -->
<SCRIPT LANGUAGE="VBScript">
<!-- Invoke MATLAB as a COM Automation server upon loading page
' Initialize global variables
Dim MatLab 'COM Automation server variable
Dim MLCmd 'string to send to MATLAB for execution
' Invoke COM Automation server
Set MatLab = CreateObject("Matlab.Application")
' End initialization script -->
</SCRIPT>

<!-- %%%%%%%%%%%%%% END SCRIPT %%%%%%%%%%%%%% -->
<!-- Create form to contain controls -->
<FORM NAME="Form">
<!-- Create pulldown menu to select which plot to view -->
<P>Select type of plot:
<SELECT NAME=plot_choice>
  <OPTION SELECTED VALUE=first>Line</OPTION>
  <OPTION VALUE=second>Peaks</OPTION>
  <OPTION VALUE=third>Logo</OPTION>
</SELECT>
<!-- Create button to create plot and fill text area -->
<P>Create figure:
<INPUT TYPE="button" NAME="plot_but" VALUE="Plot">

<!-- %%%%%%%%%%%%%% BEGIN SCRIPT %%%%%%%%%%%%%% -->
<SCRIPT FOR="plot_but" EVENT="onClick" LANGUAGE="VBScript">
<!-- Start script
Dim plot_choice
Dim text_str 'string to display in text area
Dim form_var 'form object variable
Set form_var = Document.Form
plot_choice = form_var.plot_choice.value
' Condition MATLAB command to execute based on plot choice
If plot_choice = "first" Then

```



```

        MLcmd = "figure; plot(1:10);"
        text_str = "Simple line plot of 1 to 10"
        Call MatLab.PutCharArray("text","base",text_str)
    ElseIf plot_choice = "second" Then
        MLcmd = "figure; mesh(peaks);"
        text_str = "Mesh plot of peaks"
        Call MatLab.PutCharArray("text","base",text_str)
    ElseIf plot_choice = "third" Then
        MLcmd = "figure; logo;"
        text_str = "MATLAB logo"
        Call MatLab.PutCharArray("text","base",text_str)
    End If
    ' Execute command in MATLAB
    MatLab.execute(MLcmd)
    ' Get variable from MATLAB into VBScript
    Call MatLab.GetWorkspaceData("text","base","text_str")
    ' Update text area
    form_var.plottext.value = text_str
    ' End script -->
</SCRIPT>

<!-- %%%%%%%%%%% END SCRIPT %%%%%%%%%%% -->
<!-- Create text area to show text -->
<P><TEXTAREA NAME="plottext" ROWS="1" COLS="50"
CONTENTEDITABLE="false"></TEXTAREA>
</FONT>
</FORM>
</BODY>
</HTML>

```

Call MATLAB Function from C# Client

This example creates data in the client C# program and passes it to MATLAB. The matrix (containing complex data) is then passed back to the C# program.

The reference to the MATLAB Type Library for C# is:

```
MApp.MApp matlab = new MApp.MApp();
```

From your C# client program, add a reference to your project to the MATLAB COM object. For example, in Microsoft Visual Studio, open your project. From the **Project** menu, select **Add Reference**. Select the **COM** tab in the Add Reference dialog box. Select the MATLAB application.

Here is the complete example:

```
using System;
namespace ConsoleApplication4
{
    class Class1
    {
        [STAThread]
        static void Main(string[] args)
        {
            MApp.MApp matlab = new MApp.MApp();

            System.Array pr = new double[4];
            pr.SetValue(11,0);
            pr.SetValue(12,1);
            pr.SetValue(13,2);
            pr.SetValue(14,3);

            System.Array pi = new double[4];
            pi.SetValue(1,0);
            pi.SetValue(2,1);
            pi.SetValue(3,2);
            pi.SetValue(4,3);

            matlab.PutFullMatrix("a", "base", pr, pi);
```

```
System.Array prresult = new double[4];
System.Array piresult = new double[4];

matlab.GetFullMatrix("a", "base", ref prresult, ref piresult);
}
}
}
```

View MATLAB Functions from Visual Basic .NET Object Browser

You can find out what methods are available from a MATLAB Automation server using the Object Browser of your Microsoft Visual Basic client application. To do this, follow this procedure in the client application to reference the MATLAB Application Type Library:

- 1** Select the **Project** menu.
- 2** Select **Reference** from the subsequent menu.
- 3** Check the box next to the **MATLAB Application Type Library**.
- 4** Click **OK**.

This enables you to view MATLAB Automation methods from the Visual Basic Object Browser under the Library called MLAPP. You can also see a list of MATLAB Automation methods when you use the term Matlab followed by a period. For example:

```
Dim Matlab As MApp.MApp
Private Sub View_Methods()
Matlab = New MApp.MApp
'The next line shows a list of MATLAB Automation methods
Matlab.
End Sub
```

Using Web Services with MATLAB

- “How You Can Use Web Services with MATLAB” on page 12-2
- “Ways of Using Web Services in MATLAB” on page 12-5
- “Access Web Services That Use WSDL Documents” on page 12-6
- “Access Web Services Using MATLAB SOAP Functions” on page 12-10
- “Considerations When Using Web Services” on page 12-13
- “Where to Get Information About Web Services” on page 12-16

How You Can Use Web Services with MATLAB

In this section...
“What Are Web Services in MATLAB?” on page 12-2
“What You Need to Use Web Services with MATLAB” on page 12-3
“Typical Applications Using Web Services with MATLAB” on page 12-4

What Are Web Services in MATLAB?

Web services allow applications running on disparate computers, operating systems, and development environments to communicate with each other. Using Web services technologies, client workstations can access and execute APIs residing on a remote server. The client and server communicate via XML-formatted messages, following the W3C® SOAP protocol, and typically via the HTTP protocol.

MATLAB acts as a Web service client, providing functions you can use to access existing Web services on a server. The functions facilitate communication with the server, relieving you of the need to work with XML, complex SOAP messages, and special Web services tools. Through these functions, you can use Web services in your normal MATLAB environment, such as in the Command Window and in MATLAB programs you write.

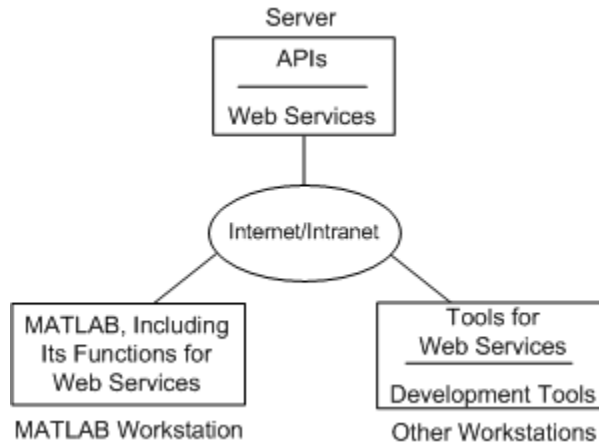

Diagram Showing Web Services in MATLAB®

An organization that wants to make APIs available to disparate clients creates the APIs and related Web service facilities for the server, using tools from Apache Axis, for example. Organizations can choose to make the Web services available only to local clients via the organization's intranet, or can offer them to the general public via the Web.

What You Need to Use Web Services with MATLAB

You need to find out from your own organization and the organizations you work with if they provide Web services of interest to you. There are publicly available Web services, some for free and some provided for a fee. For links to some of these Web services, see “Where to Get Information About Web Services” on page 12-16.

Functions for MATLAB Web services work with Web services that comply with the Basic Profile 1 to SOAP Binding specification. To find out more about the SOAP standards, see the links in “Where to Get Information About Web Services” on page 12-16.

You need to know basic information about the Web services you want to use.

You need access to the server from the workstation where you use MATLAB. If there is a proxy server, you need to provide settings for it to MATLAB using Web preferences. To do so, on the **Home** tab, in the **Environment** section,

click **Preferences > Web**. For more information, click the **Help** button in the Preferences dialog box.

Typical Applications Using Web Services with MATLAB

Accessing Data from a Server

You are creating new climate models using MATLAB, and you want to use climate data from a database housed at a government weather bureau. The bureau's server provides access to the database via Web services so that anyone who has Web service client technologies can retrieve the data, regardless of their operating system or development tools. You use functions for MATLAB Web services to get the data from the server, and then you use the data in MATLAB to develop your models.

Running Computations on a Server

A weather bureau provides Web services that allow you to run complex models on their systems, using your data and parameters. You use functions for MATLAB Web services to specify your input, run the models on the bureau's server, and get back the results for your use in MATLAB.

Updating a Database on a Server

A weather bureau provides a Web service for researchers involved in a widespread climate study to submit their results. Researchers use a variety of systems and tools, but they need to provide their results using the server's Web service facilities. As one of the researchers, you use MATLAB to generate the results for the study, and you use functions for MATLAB Web services to submit your results to the server.

Activating MATLAB License

If you have activated MATLAB, you used a Web service. After you install MATLAB, you activate your installation by getting a license file from a server at MathWorks. To get the file for your installation, MATLAB uses a Web service provided on a MathWorks server. With the activation Web service, you provide information to MathWorks, and in return, the server provides a license file to your MATLAB installation. MATLAB provides a user interface for the activation that makes you unaware you are using a Web service.

Ways of Using Web Services in MATLAB

Two Basic Ways to Access Web Services from MATLAB

There are two primary ways for using Web services in MATLAB, using the `createClassFromWsd1` function, or using the SOAP functions. When the Web service you want to use provides a Web Services Description Language (WSDL) document, use the MATLAB `createClassFromWsd1` function because it provides a more convenient way to work with the service. The `createClassFromWsd1` function actually uses the SOAP functions, but with it, you do not need to know how to use the SOAP protocol. When the Web service does not provide a WSDL document, use the MATLAB SOAP functions: `createSoapMessage`, `callSoapService`, and `parseSoapResponse`.

If you want to perform similar tasks with different Web services that provide WSDL documents, you might be able to create and use less code by using the SOAP functions instead of the `createClassFromWsd1` function.

How MATLAB Accesses Web Services

Both the `createClassFromWsd1` function and the SOAP functions access Web services in the same basic way:

- 1** You initiate interaction with the server by sending a request via MATLAB Web service functions. You provide input about the location of the Web service, the operation you want to perform, and any necessary parameters.
- 2** From your input, MATLAB constructs the SOAP message and sends it to the server.
- 3** When the server receives the request, it performs the processing and sends a SOAP response back to MATLAB.
- 4** MATLAB handles the response from the server, extracting data from the SOAP message and converting it for use in MATLAB.

Access Web Services That Use WSDL Documents

In this section...
“Using the <code>createClassFromWsd1</code> Function” on page 12-6
“Example — <code>createClassFromWsd1</code> Function” on page 12-7

Using the `createClassFromWsd1` Function

A WSDL document uses a standard format to describe a server’s operations, arguments, and transactions. The `createClassFromWsd1` function creates a MATLAB class that allows you to use the server APIs.

To use the `createClassFromWsd1` function, you need to know the location of the Web service’s WSDL document. The `createClassFromWsd1` function works with WSDL documents that comply with the WS-I 1.0 standard and use one of these forms: RPC-encoded, RPC-literal, Document-literal, or Document-literal-wrapped.

If the Web service does not provide a WSDL document, see “Access Web Services Using MATLAB SOAP Functions” on page 12-10 for an alternative.

Here are the basic steps for using the `createClassFromWsd1` function:

- 1 Change the MATLAB current folder to the location where you want to use the files generated from the WSDL document.
- 2 Run `createClassFromWsd1`, supplying the WSDL document location, which can be a URL or a path to a file.

The function converts the server’s APIs to a MATLAB class, and creates a class folder in the current folder. The class folder contains methods for using the server’s APIs. The function always creates a constructor method that has the same name as the class, and a display method for the class, called `display`.

Note You only need to run the `createClassFromWsd1` function once. You can access the class anytime after that.

For more information, see the `createClassFromWsd1` reference page

- 3** Create an object of the class whenever you want to use the operations of the Web service.
- 4** View information about the class to see what methods (operations) are available for you to use.
- 5** Use the methods of the object to run applications on and exchange data with the server.

The methods create SOAP messages and send them to the server. The server performs operations and sends data back to MATLAB.

MATLAB automatically converts SOAP data types to MATLAB types, and vice versa—for more information, see “XML-MATLAB Data Type Conversion Used in Web Services” on page 12-13.

Example – `createClassFromWsd1` Function

This example retrieves information from a database that provides standardized test scores. The WSDL document is located at <http://examplestandardtests.com/scoreswebservice?WSDL>.

Note The example does not use an actual WSDL document; therefore, you cannot run it. The example only illustrates how to use the function.

- 1** Run the `createClassFromWsd1` statement:

```
createClassFromWsd1('http://examplestandardtests.com/scoreswebservice?WSDL')
```

MATLAB creates the class folder `@TestScoreWebService` in the current folder and displays the name:

```
ans = TestScoreWebService
```

- 2** Create an object of the class by running

```
obj = TestScoreWebService
```

MATLAB returns:

```
endpoint: 'http://examplestandardtests.com/scoreswebservice'  
wsdl: 'http://examplestandardtests.com/scoreswebservice?WSDL'
```

3 View the methods of the class to see what you can do. These are two ways to view the methods:

- Run `methods(obj)`.
- In the Current Folder browser, view the contents of the `@TestScoreWebService` folder. The description shows the syntax for the methods.

For the example, the methods include:

```
display  
StudentNames  
Tests  
TestScoreWebService
```

4 Use the `StudentNames` method to retrieve the names of all students who took tests by running

```
students = StudentNames(obj)
```

MATLAB returns a structure with the names of test takers:

```
students =  
  
    StudentInfo: [125x1 struct]
```

5 View the data in the first element by running

```
students.StudentInfo(1)
```

MATLAB returns:

```
StudentNameLast: 'Benjamin'  
StudentNameFirst: 'Ali'
```

Alternatively, you can view the information using the Variables editor by running

```
openvar(students)
```

Then in the Variables editor, double-click `StudentInfo`. In the resulting pane, double-click the first `<1x1 struct>` to view the information. For more information, see “Copy, Paste, and Rename Variables”.

Access Web Services Using MATLAB SOAP Functions

In this section...
“Using the MATLAB SOAP Functions” on page 12-10
“Example — SOAP Functions” on page 12-10

Using the MATLAB SOAP Functions

To use the `createSoapMessage`, `callSoapService`, and `parseSoapResponse` functions, you need some knowledge of SOAP as well as specific information about the Web services you want to use, such as the endpoint and the operations. If the server provides a WSDL document, see “Access Web Services That Use WSDL Documents” on page 12-6 for a potentially more convenient option.

This is a typical way to use the SOAP functions. For details about each function, see the function reference page.

- 1 Construct a message you want to send to the server using `createSoapMessage`. Provide this input to the function: namespace of the server, name of the server operations you want to run, input you need to provide for that operations, parameter of the operation, data types, and message style (optional).
- 2 Send the message to the server using `callSoapService`. Provide this input to the function: endpoint, SOAP action, and the SOAP message you created in step 1. MATLAB returns the reply from the server.
- 3 Convert the reply from the server and extract the desired data into a MATLAB variable using `parseSoapResponse`. MATLAB automatically converts SOAP data types to MATLAB data types—for more information, see “XML-MATLAB Data Type Conversion Used in Web Services” on page 12-13.

Example — SOAP Functions

This example retrieves information about books from a library database, specifically, the author’s name for a given book title.

Note The example does not use an actual endpoint; therefore, you cannot run it. The example only illustrates how to use the SOAP functions.

- 1 Create a SOAP message that retrieves the name of the author of a book titled “In the Fall”:

```
message = createSoapMessage(...
    'urn:LibraryCatalog',... % Relative path to namespace of library service on local intranet
    'getAuthor',... % Method (operation) provided by service to retrieve author's name
    {'In the Fall'},... % Input that method requires; here, the title of the book
    {'nameToLookUp'},... % Name of parameter of getAuthor
    {'{http://www.w3.org/2001/XMLSchema}string'},... % Data type for the result
    'rpc') % SOAP message style
```

MATLAB returns

```
message =

[#document: null]
```

This response does not necessarily indicate that the message is valid, although certain input problems produce an error message.

- 2 Send the message to the server for processing, and get the result (author’s name) back from the server in a SOAP message:

```
response = callSoapService('http://test/soap/services/LibraryCatalog',... % Service's endpoint
    'urn:LibraryCatalog#getAuthor',... % Server method to run
    message) % SOAP message created using createSoapMessage
```

MATLAB returns the following SOAP message in one long line (displayed here in separate lines for legibility):

```
<?xml version="1.0" encoding="utf-8"?>
<soapenv:Envelope
xmlns:soapenv="http://schemas.xmlsoap.org/soap/envelope/"
xmlns:xsd="http://www.w3.org/2001/XMLSchema"
xmlns:xsi="http://www.w3.org/2001/XMLSchema-instance">
<soapenv:Body>
<getAuthorResponse xmlns="urn:LibraryCatalog">
```

```
<ns1:getAuthorReturn xmlns:ns1="http://latestversion.soap.test">
Kate Alvin
</ns1:getAuthorReturn>
</getAuthorResponse>
</soapenv:Body>
</soapenv:Envelope>
```

- 3** Extract the author's name from the SOAP message returned by the server in step 2:

```
author = parseSoapResponse(response)
```

MATLAB returns:

```
author = Kate Alvin
```

In MATLAB, `author` is a char class. MATLAB automatically converted the XML string data type to char.

Considerations When Using Web Services

In this section...

“XML-MATLAB Data Type Conversion Used in Web Services” on page 12-13

“Programming with Web Services” on page 12-14

XML-MATLAB Data Type Conversion Used in Web Services

MATLAB SOAP functions automatically convert XML data types used in SOAP messages to MATLAB types (classes), and vice-versa. The following table contains the XML type and the corresponding MATLAB type.

XML Data Type	MATLAB Type (Class)
string	char array
boolean	logical scalar
decimal	double scalar
float	double scalar
double	double scalar
duration	double scalar
time	double scalar
date	double scalar
gYearMonth	char array
gYear	char array
gMonthDay	char array
hexbinary	double array
base64Binary	double array
anyURI	char array
QName	char array

Programming with Web Services

When creating MATLAB files that rely on Web services, consider the following:

- If the Web service you want to use is on the Internet, your application performance could be unpredictable because it depends in part on Internet performance.
- Conventions and established procedures for Web services and related technologies, like WSDL and SOAP, are still evolving. You could find inconsistencies or unexpected behavior when using Web services.
- A Web service could change over time, which can impact its usage and results in MATLAB.

Use common program control and error-handling routines to minimize the risks, such as:

- Use try/catch statements to catch errors that result from method calls or from the `createClassFromWsd1` function.
- Use If statements to determine if expressions or statements are true or false. For example, if you have a valid URL for a WSDL document, you can determine whether or not you have a local copy of the WSDL document. If you do not, you can achieve better performance if you create a local copy and use the local copy instead of the version at the URL:

```
wsd1Url = ['http://www.xmethods.net/sd/2001' ...  
          '/CurrencyExchangeService.wsdl'];  
wsdlFile = 'CurrencyExchangeService.wsdl';
```

the following if statement stores the WSDL locally, if it does not already exist:

```
if ~(exist(wsdlFile,'file') == 2)  
    urlwrite(wsd1Url,wsdlFile);  
end
```

- Use error functions to report specific errors. The following example shows an error function used in an try/catch statement:

```
try
```

```
    students = studentNames(obj);  
catch  
    error('Could not return name.');
```

```
end
```

For more information about program control and error-handling statements, see “Exception Handling in a MATLAB Application”.

Where to Get Information About Web Services

Resources for Web Services and SOAP

- Wikipedia® entry for Web Service
- Wikipedia entry for SOAP (protocol)
- World Wide Web Consortium (W3C) SOAP specification
- W3C status codes for HTTP errors
- W3 Schools SOAP Tutorial

Resources for WSDL

- Wikipedia entry for Web Services Description Language (WSDL)
- W3C WSDL specification
- Web Services Description Language for Java Toolkit (WSDL4J), tools for creating and working with WSDL documents.
- W3 Schools WSDL Tutorial

Tools for Creating Web Services

- Oracle® Java Web Services
- Microsoft Developer Network—Web Services
- Apache Axis Web Services

Serial Port I/O

- “Introduction” on page 13-2
- “Overview of the Serial Port” on page 13-5
- “Getting Started with Serial I/O” on page 13-20
- “Creating a Serial Port Object” on page 13-27
- “Connecting to the Device” on page 13-32
- “Configuring Communication Settings” on page 13-33
- “Writing and Reading Data” on page 13-34
- “Events and Callbacks” on page 13-55
- “Using Control Pins” on page 13-65
- “Debugging: Recording Information to Disk” on page 13-71
- “Saving and Loading” on page 13-78
- “Disconnecting and Cleaning Up” on page 13-80
- “Property Reference” on page 13-82
- “Properties — Alphabetical List” on page 13-86

Introduction

In this section...
“What Is the MATLAB Serial Port Interface?” on page 13-2
“Supported Serial Port Interface Standards” on page 13-3
“Supported Platforms” on page 13-3
“Using the Examples with Your Device” on page 13-3

What Is the MATLAB Serial Port Interface?

The MATLAB serial port interface provides direct access to peripheral devices such as modems, printers, and scientific instruments that you connect to your computer’s serial port. This interface is established through a serial port object. The serial port object supports functions and properties that allow you to

- Configure serial port communications
- Use serial port control pins
- Write and read data
- Use events and callbacks
- Record information to disk

Instrument Control Toolbox™ software provides additional serial port functionality. In addition to command-line access, this toolbox has a graphical tool called the Test & Measurement Tool, which allows you to communicate with, configure, and transfer data with your serial device without writing code. The Test & Measurement Tool generates MATLAB code for your serial device that you can later reuse to communicate with your device or to develop GUI-based applications. The toolbox includes additional serial I/O utility functions that facilitate object creation and configuration, instrument communication, and so on. With the toolbox you can communicate with GPIB- or VISA-compatible instruments.

If you want to communicate with PC-compatible data acquisition hardware such as multifunction I/O boards, you need Data Acquisition Toolbox™ software.

For more information about these products, visit the MathWorks Web site at <http://www.mathworks.com/products>.

Supported Serial Port Interface Standards

Over the years, several serial port interface standards have been developed. These standards include RS-232, RS-422, and RS-485 - all of which are supported by the MATLAB serial port object. Of these, the most widely used interface standard for connecting computers to peripheral devices is RS-232.

This guide assumes you are using the RS-232 standard, discussed in “Overview of the Serial Port” on page 13-5. Refer to your computer and device documentation to see which interface standard you can use.

Supported Platforms

The MATLAB serial port interface is supported on:

- Linux 32-bit
- Linux 64-bit
- Mac OS X
- Mac OS X 64-bit
- Microsoft Windows 32-bit
- Microsoft Windows 64-bit

Using the Examples with Your Device

Many of the examples in this section reflect specific peripheral devices connected to a serial port — in particular a Tektronix® TDS 210 two-channel oscilloscope connected to the COM1 port, on a Windows platform. Therefore, many of the string commands are specific to this instrument and platform.

If you are using a different platform, or your peripheral device is connected to a different serial port, or if it accepts different commands, modify the examples accordingly.

Overview of the Serial Port

In this section...

“Introduction” on page 13-5

“What Is Serial Communication?” on page 13-5

“The Serial Port Interface Standard” on page 13-6

“Connecting Two Devices with a Serial Cable” on page 13-6

“Serial Port Signals and Pin Assignments” on page 13-7

“Serial Data Format” on page 13-11

“Finding Serial Port Information for Your Platform” on page 13-16

“Using Virtual USB Serial Ports” on page 13-18

“Selected Bibliography” on page 13-18

Introduction

For many serial port applications, you can communicate with your device without detailed knowledge of how the serial port works. If your application is straightforward, or if you are already familiar with the previously mentioned topics, you might want to begin with “The Serial Port Session” on page 13-21 to see how to use your serial port device with MATLAB software.

What Is Serial Communication?

Serial communication is the most common low-level protocol for communicating between two or more devices. Normally, one device is a computer, while the other device can be a modem, a printer, another computer, or a scientific instrument such as an oscilloscope or a function generator.

As the name suggests, the serial port sends and receives bytes of information in a serial fashion — one bit at a time. These bytes are transmitted using either a binary (numerical) format or a text format.

The Serial Port Interface Standard

The serial port interface for connecting two devices is specified by the TIA/EIA-232C standard published by the Telecommunications Industry Association.

The original serial port interface standard was given by RS-232, which stands for Recommended Standard number 232. The term *RS-232* is still in popular use, and is used in this guide when referring to a serial communication port that follows the TIA/EIA-232 standard. RS-232 defines these serial port characteristics:

- The maximum bit transfer rate and cable length
- The names, electrical characteristics, and functions of signals
- The mechanical connections and pin assignments

Primary communication is accomplished using three pins: the Transmit Data pin, the Receive Data pin, and the Ground pin. Other pins are available for data flow control, but are not required.

Other standards such as RS-485 define additional functionality such as higher bit transfer rates, longer cable lengths, and connections to as many as 256 devices.

Connecting Two Devices with a Serial Cable

The RS-232 standard defines the two devices connected with a serial cable as the Data Terminal Equipment (DTE) and Data Circuit-Terminating Equipment (DCE). This terminology reflects the RS-232 origin as a standard for communication between a computer terminal and a modem.

Throughout this guide, your computer is considered a DTE, while peripheral devices such as modems and printers are considered DCEs. Many scientific instruments function as DTEs.

Because RS-232 mainly involves connecting a DTE to a DCE, the pin assignments are defined such that straight-through cabling is used, where pin 1 is connected to pin 1, pin 2 is connected to pin 2, and so on. The following diagram shows a DTE to DCE serial connection using the transmit data (TD) pin and the receive data (RD) pin.

For more information about serial port pins, see “Serial Port Signals and Pin Assignments” on page 13-7.



If you connect two DTEs or two DCEs using a straight serial cable, the TD pins on each device are connected to each other, and the RD pins on each device are connected to each other. Therefore, to connect two like devices, you must use a *null modem* cable. As shown in the following diagram, null modem cables cross the transmit and receive lines in the cable.

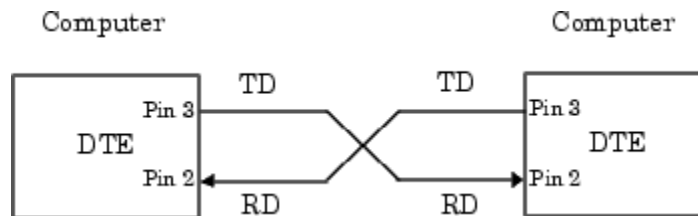

Note You can connect multiple RS-422 or RS-485 devices to a serial port. If you have an RS-232/RS-485 adaptor, you can use the MATLAB serial port object with these devices.

Serial Port Signals and Pin Assignments

Serial ports consist of two signal types: data signals and control signals. To support these signal types, as well as the signal ground, the RS-232 standard defines a 25-pin connection. However, most Windows and UNIX platforms use a 9-pin connection. In fact, only three pins are required for serial port communications: one for receiving data, one for transmitting data, and one for the signal ground.

The following diagram shows the pin assignment scheme for a 9-pin male connector on a DTE.

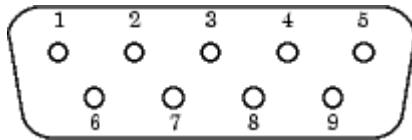

The pins and signals associated with the 9-pin connector are described in the following table. Refer to the RS-232 standard for a description of the signals and pin assignments used for a 25-pin connector.

Serial Port Pin and Signal Assignments

Pin	Label	Signal Name	Signal Type
1	CD	Carrier Detect	Control
2	RD	Received Data	Data
3	TD	Transmitted Data	Data
4	DTR	Data Terminal Ready	Control
5	GND	Signal Ground	Ground
6	DSR	Data Set Ready	Control
7	RTS	Request to Send	Control
8	CTS	Clear to Send	Control
9	RI	Ring Indicator	Control

The term *data set* is synonymous with *modem* or *device*, while the term *data terminal* is synonymous with *computer*.

Note The serial port pin and signal assignments are with respect to the DTE. For example, data is transmitted from the TD pin of the DTE to the RD pin of the DCE.

Signal States

Signals can be in either an *active* state or an *inactive* state. An active state corresponds to the binary value 1, while an inactive state corresponds to the binary value 0. An active signal state is often described as *logic 1*, *on*, *true*, or a *mark*. An inactive signal state is often described as *logic 0*, *off*, *false*, or a *space*.

For data signals, the on state occurs when the received signal voltage is more negative than -3 volts, while the off state occurs for voltages more positive than 3 volts. For control signals, the on state occurs when the received signal voltage is more positive than 3 volts, while the off state occurs for voltages more negative than -3 volts. The voltage between -3 volts and +3 volts is considered a transition region, and the signal state is undefined.

To bring the signal to the on state, the controlling device *unasserts* (or *lowers*) the value for data pins and *asserts* (or *raises*) the value for control pins. Conversely, to bring the signal to the off state, the controlling device asserts the value for data pins and unasserts the value for control pins.

The following diagram shows the on and off states for a data signal and for a control signal.

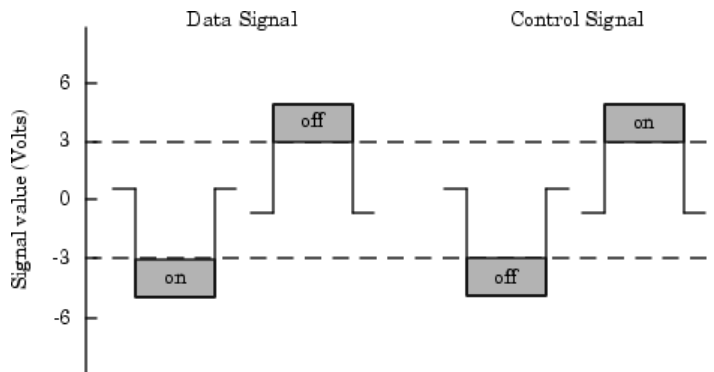

The Data Pins

Most serial port devices support *full-duplex* communication meaning that they can send and receive data at the same time. Therefore, separate pins are used for transmitting and receiving data. For these devices, the TD, RD,

and GND pins are used. However, some types of serial port devices support only one-way or *half-duplex* communications. For these devices, only the TD and GND pins are used. This guide assumes that a full-duplex serial port is connected to your device.

The TD pin carries data transmitted by a DTE to a DCE. The RD pin carries data that is received by a DTE from a DCE.

The Control Pins

The control pins of a 9-pin serial port are used to determine the presence of connected devices and control the flow of data. The control pins include

- “The RTS and CTS Pins” on page 13-10
- “The DTR and DSR Pins” on page 13-10
- “The CD and RI Pins” on page 13-11

The RTS and CTS Pins. The RTS and CTS pins are used to signal whether the devices are ready to send or receive data. This type of data flow control—called *hardware handshaking*—is used to prevent data loss during transmission. When enabled for both the DTE and DCE, hardware handshaking using RTS and CTS follows these steps:

- 1** The DTE asserts the RTS pin to instruct the DCE that it is ready to receive data.
- 2** The DCE asserts the CTS pin indicating that it is clear to send data over the TD pin. If data can no longer be sent, the CTS pin is unasserted.
- 3** The data is transmitted to the DTE over the TD pin. If data can no longer be accepted, the RTS pin is unasserted by the DTE and the data transmission is stopped.

To enable hardware handshaking in MATLAB software, see “Controlling the Flow of Data: Handshaking” on page 13-68.

The DTR and DSR Pins. Many devices use the DSR and DTR pins to signal if they are connected and powered. Signaling the presence of connected devices using DTR and DSR follows these steps:

- 1 The DTE asserts the DTR pin to request that the DCE connect to the communication line.
- 2 The DCE asserts the DSR pin to indicate it is connected.
- 3 DCE unasserts the DSR pin when it is disconnected from the communication line.

The DTR and DSR pins were originally designed to provide an alternative method of hardware handshaking. However, the RTS and CTS pins are usually used in this way, and not the DSR and DTR pins. Refer to your device documentation to determine its specific pin behavior.

The CD and RI Pins. The CD and RI pins are typically used to indicate the presence of certain signals during modem-modem connections.

A modem uses a CD pin to signal that it has made a connection with another modem, or has detected a carrier tone. CD is asserted when the DCE is receiving a signal of a suitable frequency. CD is unasserted if the DCE is not receiving a suitable signal.

The RI pin is used to indicate the presence of an audible ringing signal. RI is asserted when the DCE is receiving a ringing signal. RI is unasserted when the DCE is not receiving a ringing signal (e.g., it is between rings).

Serial Data Format

The serial data format includes one start bit, between five and eight data bits, and one stop bit. A parity bit and an additional stop bit might be included in the format as well. The following diagram illustrates the serial data format.

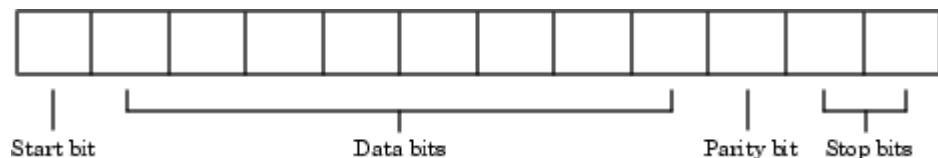

The following notation expresses the format for serial port data:

number of data bits - parity type - number of stop bits

For example, 8-N-1 is interpreted as eight data bits, no parity bit, and one stop bit, while 7-E-2 is interpreted as seven data bits, even parity, and two stop bits.

The data bits are often referred to as a *character* because these bits usually represent an ASCII character. The remaining bits are called *framing bits* because they frame the data bits.

Bytes Versus Values

A *byte* is the collection of bits that comprise the serial data format. At first, this term might seem inaccurate because a byte is 8 bits and the serial data format can range between 7 bits and 12 bits. However, when serial data is stored on your computer, the framing bits are stripped away, and only the data bits are retained. Moreover, eight data bits are always used regardless of the number of data bits specified for transmission, with the unused bits assigned a value of 0.

When reading or writing data, you might need to specify a *value*, which can consist of one or more bytes. For example, if you read one value from a device using the `int32` format, that value consists of four bytes. For more information about reading and writing values, see “Writing and Reading Data” on page 13-34.

Synchronous and Asynchronous Communication

The RS-232 standard supports two types of communication protocols: synchronous and asynchronous.

Using the synchronous protocol, all transmitted bits are synchronized to a common clock signal. The two devices initially synchronize themselves to each other, and continually send characters to stay synchronized. Even when actual data is not really being sent, a constant flow of bits allows each device to know where the other is at any given time. That is, each bit that is sent is either actual data or an idle character. Synchronous communications allows faster data transfer rates than asynchronous methods, because additional bits to mark the beginning and end of each data byte are not required.

Using the asynchronous protocol, each device uses its own internal clock, resulting in bytes that are transferred at arbitrary times. So, instead of using time as a way to synchronize the bits, the data format is used.

In particular, the data transmission is synchronized using the start bit of the word, while one or more stop bits indicate the end of the word. The requirement to send these additional bits causes asynchronous communications to be slightly slower than synchronous. However, it has the advantage that the processor does not have to deal with the additional idle characters. Most serial ports operate asynchronously.

Note When used in this guide, the terms *synchronous* and *asynchronous* refer to whether read or write operations block access to the MATLAB command line. For more information, see “Controlling Access to the MATLAB Command Line” on page 13-35.

How Are the Bits Transmitted?

By definition, serial data is transmitted one bit at a time. The order in which the bits are transmitted is:

- 1 The start bit is transmitted with a value of 0.
- 2 The data bits are transmitted. The first data bit corresponds to the least significant bit (LSB), while the last data bit corresponds to the most significant bit (MSB).
- 3 The parity bit (if defined) is transmitted.
- 4 One or two stop bits are transmitted, each with a value of 1.

The *baud rate* is the number of bits transferred per second. The transferred bits include the start bit, the data bits, the parity bit (if defined), and the stop bits.

Start and Stop Bits

As described in “Synchronous and Asynchronous Communication” on page 13-12, most serial ports operate asynchronously. This means that the

transmitted byte must be identified by start and stop bits. The start bit indicates when the data byte is about to begin; the stop bit(s) indicate(s) when the data byte has been transferred. The process of identifying bytes with the serial data format follows these steps:

- 1** When a serial port pin is idle (not transmitting data), it is in an on state.
- 2** When data is about to be transmitted, the serial port pin switches to an off state due to the start bit.
- 3** The serial port pin switches back to an on state due to the stop bit(s). This indicates the end of the byte.

Data Bits

The data bits transferred through a serial port might represent device commands, sensor readings, error messages, and so on. The data can be transferred as either binary data or ASCII data.

Most serial ports use between five and eight data bits. Binary data is typically transmitted as eight bits. Text-based data is transmitted as either seven bits or eight bits. If the data is based on the ASCII character set, a minimum of seven bits is required because there are 2^7 or 128 distinct characters. If an eighth bit is used, it must have a value of 0. If the data is based on the extended ASCII character set, eight bits must be used because there are 2^8 or 256 distinct characters.

The Parity Bit

The parity bit provides simple error (parity) checking for the transmitted data. The following table shows the types of parity checking.

Parity Types

Parity Type	Description
Even	The data bits plus the parity bit result in an even number of 1s.
Mark	The parity bit is always 1.

Parity Types (Continued)

Parity Type	Description
Odd	The data bits plus the parity bit result in an odd number of 1s.
Space	The parity bit is always 0.

Mark and space parity checking are seldom used because they offer minimal error detection. You might choose to not use parity checking at all.

The parity checking process follows these steps:

- 1** The transmitting device sets the parity bit to 0 or to 1, depending on the data bit values and the type of parity-checking selected.
- 2** The receiving device checks if the parity bit is consistent with the transmitted data. If it is, the data bits are accepted. If it is not, an error is returned.

Note Parity checking can detect only 1-bit errors. Multiple-bit errors can appear as valid data.

For example, suppose the data bits 01110001 are transmitted to your computer. If even parity is selected, the parity bit is set to 0 by the transmitting device to produce an even number of 1s. If odd parity is selected, the parity bit is set to 1 by the transmitting device to produce an odd number of 1s.

Finding Serial Port Information for Your Platform

This section describes the ways to find serial port information for Windows and UNIX platforms.

Note Your operating system provides default values for all serial port settings. However, these settings are overridden by your MATLAB code, and will have no effect on your serial port application.

Microsoft Windows Platform

You can access serial port information through the **System Properties** dialog. To access this on a Windows XP platform,

- 1** Right-click **My Computer** on the desktop, and select **Properties**.
- 2** In the **System Properties** dialog, click the **Hardware** tab.
- 3** Click **Device Manager**.
- 4** In the **Device Manager** dialog, expand the Ports node.
- 5** Double-click the Communications Port (COM1) node.
- 6** Select the **Port Settings** tab.

MATLAB displays the following Ports dialog box.

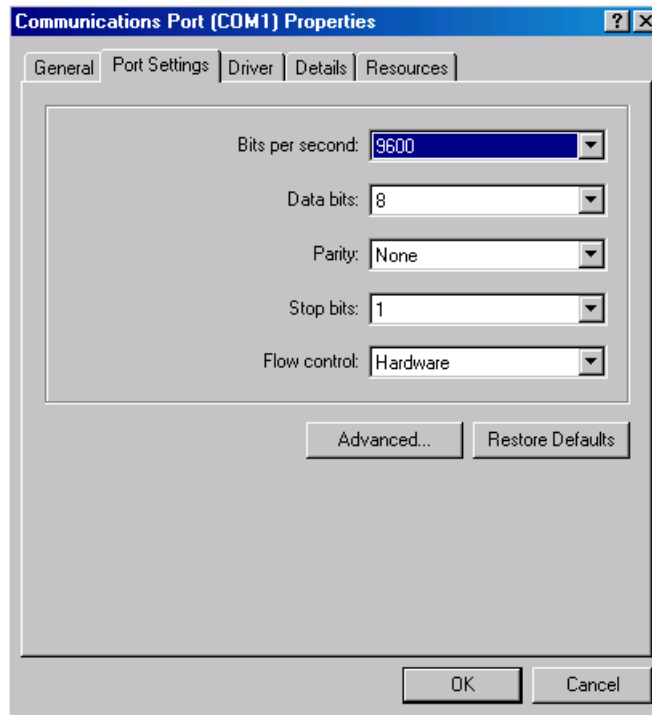

UNIX Platform

To find serial port information for UNIX platforms, you need to know the serial port names. These names might vary between different operating systems.

On a Linux platform, serial port devices are typically named `ttyS0`, `ttyS1`, etc. Use the `setserial` command to display or configure serial port information. For example, to display which ports are available:

```
setserial -bg /dev/ttyS*  
/dev/ttyS0 at 0x03f8 (irq = 4) is a 16550A  
/dev/ttyS1 at 0x02f8 (irq = 3) is a 16550A
```

To display detailed information about `ttyS0`:

```
setserial -ag /dev/ttyS0
/dev/ttyS0, Line 0, UART: 16550A, Port: 0x03f8, IRQ: 4
    Baud_base: 115200, close_delay: 50, divisor: 0
    closing_wait: 3000, closing_wait2: infinte
    Flags: spd_normal skip_test session_lockout
```

Note If the `setserial -ag` command does not work, make sure that you have read and write permission for the port.

For all supported UNIX platforms, use the `stty` command to display or configure serial port information. For example, to display serial port properties for `ttyS0`, enter:

```
stty -a < /dev/ttyS0
```

To configure the baud rate to 4800 bits per second, enter:

```
stty speed 4800 < /dev/ttyS0 > /dev/ttyS0
```

Using Virtual USB Serial Ports

If you have devices that present themselves as serial ports on your operating system, you can use them as virtual USB serial ports in MATLAB. An example of such devices would be a USB Serial Dongle. For Bluetooth[®] devices, you can use the Bluetooth support in the Instrument Control Toolbox. See “Bluetooth Interface Overview” for more information.

MATLAB can communicate with these devices as long as the serial drivers provided by the device vendor are able to emulate the native hardware. Certain software, like HyperTerminal, does not require the device driver to fully implement and support the native hardware.

Selected Bibliography

[1] TIA/EIA-232-F, *Interface Between Data Terminal Equipment and Data Circuit-Terminating Equipment Employing Serial Binary Data Interchange*.

- [2] Jan Axelson, *Serial Port Complete*, Lakeview Research, Madison, WI, 1998.
- [3] *Instrument Communication Handbook*, IOTech, Inc., Cleveland, OH, 1991.
- [4] *TDS 200-Series Two Channel Digital Oscilloscope Programmer Manual*, Tektronix, Inc., Wilsonville, OR.
- [5] *Courier High Speed Modems User's Manual*, U.S. Robotics, Inc., Skokie, IL, 1994.

Getting Started with Serial I/O

In this section...
“Example: Getting Started” on page 13-20
“The Serial Port Session” on page 13-21
“Configuring and Returning Properties” on page 13-22

Example: Getting Started

This example illustrates some basic serial port commands.

Note This example is shown on a Windows platform.

If you have a device connected to the serial port COM1 and configured for a baud rate of 4800, execute the following example.

```
s = serial('COM1');
set(s, 'BaudRate', 4800);
fopen(s);
fprintf(s, '*IDN?')
out = fscanf(s);
fclose(s);
delete(s);
clear s
```

The *IDN? command queries the device for identification information, which is returned to out. If your device does not support this command, or if it is connected to a different serial port, modify the previous example accordingly.

Note *IDN? is one of the commands supported by the Standard Commands for Programmable Instruments (SCPI) language, which is used by many modern devices. Refer to your device documentation to see if it supports the SCPI language.

The Serial Port Session

This example describes the steps you use to perform any serial port task from beginning to end.

The serial port *session* comprises all the steps you are likely to take when communicating with a device connected to a serial port. These steps are:

- 1 Create a serial port object** — Create a serial port object for a specific serial port using the `serial` creation function.

Configure properties during object creation if necessary. In particular, you might want to configure properties associated with serial port communications such as the baud rate, the number of data bits, and so on.

- 2 Connect to the device** — Connect the serial port object to the device using the `fopen` function.

After the object is connected, alter the necessary device settings by configuring property values, read data, and write data.

- 3 Configure properties** — To establish the desired serial port object behavior, assign values to properties using the `set` function or dot notation.

In practice, you can configure many of the properties at any time including during, or just after, object creation. Conversely, depending on your device settings and the requirements of your serial port application, you might be able to accept the default property values and skip this step.

- 4 Write and read data** — Write data to the device using the `fprintf` or `fwrite` function, and read data from the device using the `fgetl`, `fgets`, `fread`, `fscanf`, or `readasync` function.

The serial port object behaves according to the previously configured or default property values.

- 5 Disconnect and clean up** — When you no longer need the serial port object, disconnect it from the device using the `fclose` function, remove it from memory using the `delete` function, and remove it from the MATLAB workspace using the `clear` command.

The serial port session is reinforced in many of the serial port documentation examples. To see a basic example that uses the steps shown above, see “Example: Getting Started” on page 13-20.

Configuring and Returning Properties

This example describes how you display serial port property names and property values, and how you assign values to properties.

You establish the desired serial port object behavior by configuring property values. You can display or configure property values using the set function, the get function, or dot notation.

Displaying Property Names and Property Values

After you create the serial port object, use the set function to display all the configurable properties to the command line. Additionally, if a property has a finite set of string values, set also displays these values.

```
s = serial('COM1');
set(s)
ByteOrder: [ {littleEndian} | bigEndian ]
BytesAvailableFcn
BytesAvailableFcnCount
BytesAvailableFcnMode: [ {terminator} | byte ]
ErrorFcn
InputBufferSize
Name
OutputBufferSize
OutputEmptyFcn
RecordDetail: [ {compact} | verbose ]
RecordMode: [ {overwrite} | append | index ]
RecordName
Tag
Timeout
TimerFcn
TimerPeriod
UserData

SERIAL specific properties:
```

```
BaudRate
BreakInterruptFcn
DataBits
DataTerminalReady: [ {on} | off ]
FlowControl: [ {none} | hardware | software ]
Parity: [ {none} | odd | even | mark | space ]
PinStatusFcn
Port
ReadAsyncMode: [ {continuous} | manual ]
RequestToSend: [ {on} | off ]
StopBits
Terminator
```

Use the get function to display one or more properties and their current values to the command line. To display all properties and their current values:

```
get(s)
ByteOrder = littleEndian
BytesAvailable = 0
BytesAvailableFcn =
BytesAvailableFcnCount = 48
BytesAvailableFcnMode = terminator
BytesToOutput = 0
ErrorFcn =
InputBufferSize = 512
Name = Serial-COM1
OutputBufferSize = 512
OutputEmptyFcn =
RecordDetail = compact
RecordMode = overwrite
RecordName = record.txt
RecordStatus = off
Status = closed
Tag =
Timeout = 10
TimerFcn =
TimerPeriod = 1
TransferStatus = idle
Type = serial
UserData = []
```

```
ValuesReceived = 0
ValuesSent = 0

SERIAL specific properties:
BaudRate = 9600
BreakInterruptFcn =
DataBits = 8
DataTerminalReady = on
FlowControl = none
Parity = none
PinStatus = [1x1 struct]
PinStatusFcn =
Port = COM1
ReadAsyncMode = continuous
RequestToSend = on
StopBits = 1
Terminator = LF
```

To display the current value for one property, supply the property name to `get`.

```
get(s, 'OutputBufferSize')
ans =
    512
```

To display the current values for multiple properties, include the property names as elements of a cell array.

```
get(s, {'Parity', 'TransferStatus'})
ans =
    'none'    'idle'
```

Use the dot notation to display a single property value.

```
s.Parity
ans =
    none
```

Configuring Property Values

You can configure property values using the `set` function:

```
set(s, 'BaudRate', 4800);
```

or the dot notation:

```
s.BaudRate = 4800;
```

To configure values for multiple properties, supply multiple property name/property value pairs to `set`.

```
set(s, 'DataBits', 7, 'Name', 'Test1-serial')
```

Note that you can configure only one property value at a time using the dot notation.

In practice, you can configure many of the properties at any time while the serial port object exists — including during object creation. However, some properties are not configurable while the object is connected to the device or when recording information to disk. For information about when a property is configurable, see “Property Reference” on page 13-82.

Specifying Property Names

Serial port property names are presented using mixed case. While this makes property names easier to read, use any case you want when specifying property names. Additionally, you need use only enough letters to identify the property name uniquely, so you can abbreviate most property names. For example, you can configure the `BaudRate` property any of these ways:

```
set(s, 'BaudRate', 4800)
set(s, 'baudrate', 4800)
set(s, 'BAUD', 4800)
```

When you include property names in a file, you should use the full property name. This practice can prevent problems with future releases of MATLAB software if a shortened name is no longer unique because of the addition of new properties.

Default Property Values

Whenever you do not explicitly define a value for a property, the default value is used. All configurable properties have default values.

Note Your operating system provides default values for all serial port settings such as the baud rate. However, these settings are overridden by your MATLAB code and have no effect on your serial port application.

If a property has a finite set of string values, the default value is enclosed by {}. For example, the default value for the `Parity` property is `none`.

```
set(s,'Parity')  
[ {none} | odd | even | mark | space ]
```

You can find the default value for any property in the property reference pages.

Creating a Serial Port Object

In this section...

“Overview of a Serial Port Object” on page 13-27

“Configuring Properties During Object Creation” on page 13-29

“The Serial Port Object Display” on page 13-29

“Creating an Array of Serial Port Objects” on page 13-30

Overview of a Serial Port Object

The `serial` function requires the name of the serial port connected to your device as an input argument. Additionally, you can configure property values during object creation. To create a serial port object associated with the serial port enter:

```
s = serial('port');
```

This creates a serial port object associated with the serial port specified by `'port'`. If `'port'` does not exist, or if it is in use, you will not be able to connect the serial port object to the device. `'port'` object name will depend upon the platform that the serial port is on. The Instrument Control Toolbox function

```
instrhwinfo('serial')
```

provides a list of available serial ports. This list is an example of serial constructors on different platforms:

Platform	Serial Constructor
Linux 32 and 64-bit	<code>serial('/dev/ttyS0');</code>
Mac OS X and Mac OS X 64-bit	<code>serial('/dev/tty.KeySerial1');</code>
Microsoft Windows 32 and 64-bit	<code>serial('com1');</code>
Sun™ Solaris™ 64-bit	<code>serial('/dev/term/a');</code>

The serial port object `s` now exists in the MATLAB workspace. You can display the class of `s` with the `whos` command.

```
whos s
  Name      Size      Bytes  Class

  s         1x1         512    serial object
```

Grand total is 11 elements using 512 bytes

Note The first time you try to access a serial port in MATLAB using the `s = serial('port')` call, make sure that the port is free and is not already open in any other application. If the port is open in another application, MATLAB cannot access it. Once you have accessed in MATLAB, you can open the same port in other applications and MATLAB will continue to use it along with any other application that has it open as well.

Once the serial port object is created, the following properties are automatically assigned values. These general-purpose properties provide descriptive information about the serial port object based on the object type and the serial port.

Descriptive General Purpose Properties

Property Name	Description
Name	Specify a descriptive name for the serial port object
Port	Indicate the platform-specific serial port name
Type	Indicate the object type

Display the values of these properties for `s` with the `get` function. On a Windows platform, it will look like this:

```
get(s,{'Name','Port','Type'})
ans =
    'Serial-COM1'    'COM1'    'serial'
```

Configuring Properties During Object Creation

You can configure serial port properties during object creation. `serial` accepts property names and property values in the same format as the `set` function. For example, you can specify property name/property value pairs.

```
s = serial('port', 'BaudRate', 4800, 'Parity', 'even');
```

If you specify an invalid property name, the object is not created. However, if you specify an invalid value for some properties (for example, `BaudRate` is set to 50), the object might be created but you are not informed of the invalid value until you connect the object to the device with the `fopen` function.

The Serial Port Object Display

The serial port object provides you with a convenient display that summarizes important configuration and state information. You can invoke the display summary these three ways:

- Type the serial port object variable name at the command line.
- Exclude the semicolon when creating a serial port object.
- Exclude the semicolon when configuring properties using the dot notation.

You can also display summary information via the Workspace browser by right-clicking an instrument object and selecting **Display Summary** from the context menu.

The display summary for the serial port object `s` on a Windows platform is:

```
Serial Port Object : Serial-COM1
```

Communication Settings

```
Port:          COM1
BaudRate:     9600
Terminator:   'LF'
```

Communication State

```
Status:       closed
RecordStatus: off
```

```
Read/Write State
  TransferStatus:    idle
  BytesAvailable:   0
  ValuesReceived:   0
  ValuesSent:       0
```

Creating an Array of Serial Port Objects

In MATLAB software, you can create an array from existing variables by concatenating those variables together. The same is true for serial port objects. For example, suppose you create the serial port objects `s1` and `s2` on a Windows platform.

```
s1 = serial('COM1');
s2 = serial('COM2');
```

You can now create a serial port object array consisting of `s1` and `s2` using the usual MATLAB syntax. To create the row array `x`, enter:

```
x = [s1 s2]
```

Instrument Object Array

Index:	Type:	Status:	Name:
1	serial	closed	Serial-COM1
2	serial	closed	Serial-COM2

To create the column array `y`, enter:

```
y = [s1;s2];
```

Note that you cannot create a matrix of serial port objects. For example, you cannot create the matrix:

```
z = [s1 s2;s1 s2];
??? Error using ==> serial/vertcat
```

Only a row or column vector of instrument objects can be created.

Depending on your application, you might want to pass an array of serial port objects to a function. For example, to configure the baud rate and parity for `s1` and `s2` using one call to `set`:

```
set(x, 'BaudRate', 19200, 'Parity', 'even')
```

Connecting to the Device

Before you can use the serial port object to write or read data, you must connect it to your device via the serial port specified in the `serial` function. You connect a serial port object to the device with the `fopen` function.

```
fopen(s)
```

Some properties are read only while the serial port object is connected and must be configured before using `fopen`. Examples include the `InputBufferSize` and the `OutputBufferSize` properties. To determine when you can configure a property, see “Property Reference” on page 13-82.

Note You can create any number of serial port objects, but you can connect only one serial port object per MATLAB session to a given serial port at a time. However, the serial port is not locked by the session, so other applications or other instances of MATLAB software can access the same serial port, which could result in a conflict, with unpredictable results.

You can examine the `Status` property to verify that the serial port object is connected to the device.

```
s.Status
ans =
open
```

As shown in the following illustration, the connection between the serial port object and the device is complete; data is readable and writable.

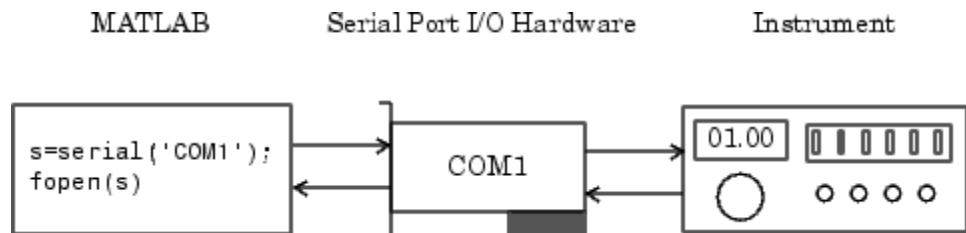

Configuring Communication Settings

Before you can write or read data, both the serial port object and the device must have identical communication settings. Configuring serial port communications involves specifying values for properties that control the baud rate and the serial data format. The following table describes these properties.

Communication Properties

Property Name	Description
BaudRate	Specify the rate at which bits are transmitted
DataBits	Specify the number of data bits to transmit
Parity	Specify the type of parity checking
StopBits	Specify the number of bits used to indicate the end of a byte
Terminator	Specify the terminator character

Note If the serial port object and the device communication settings are not identical, data is not readable or writable.

Refer to the device documentation for an explanation of its supported communication settings.

Writing and Reading Data

In this section...

“Before You Begin” on page 13-34

“Example — Introduction to Writing and Reading Data” on page 13-34

“Controlling Access to the MATLAB Command Line” on page 13-35

“Writing Data” on page 13-36

“Reading Data” on page 13-42

“Example — Writing and Reading Text Data” on page 13-48

“Example — Parsing Input Data Using textscan” on page 13-50

“Example — Reading Binary Data” on page 13-51

Before You Begin

For many serial port applications, there are three important questions that you should consider when writing or reading data:

- Will the read or write function block access to the MATLAB command line?
- Is the data to be transferred binary (numerical) or text?
- Under what conditions will the read or write operation complete?

For write operations, these questions are answered in “Writing Data” on page 13-36. For read operations, these questions are answered in “Reading Data” on page 13-42.

Note All the examples shown below are based on a Windows 32-bit platform. Refer to “Overview of a Serial Port Object” on page 13-27 section for information about other platforms.

Example — Introduction to Writing and Reading Data

Suppose you want to return identification information for a Tektronix TDS 210 two-channel oscilloscope connected to the serial port COM1 on a Windows

platform. This requires writing the `*IDN?` command to the instrument using the `fprintf` function, and reading back the result of that command using the `fscanf` function.

```
s = serial('COM1');  
fopen(s)  
fprintf(s, '*IDN?')  
out = fscanf(s)
```

The resulting identification information is:

```
out =  
TEKTRONIX, TDS 210, 0, CF:91.1CT FV:v1.16 TDS2CM:CMV:v1.04
```

End the serial port session.

```
fclose(s)  
delete(s)  
clear s
```

Controlling Access to the MATLAB Command Line

You control access to the MATLAB command line by specifying whether a read or write operation is *synchronous* or *asynchronous*.

A synchronous operation blocks access to the command line until the read or write function completes execution. An asynchronous operation does not block access to the command line, and you can issue additional commands while the read or write function executes in the background.

The terms *synchronous* and *asynchronous* are often used to describe how the serial port operates at the hardware level. The RS-232 standard supports an asynchronous communication protocol. Using this protocol, each device uses its own internal clock. The data transmission is synchronized using the start bit of the bytes, while one or more stop bits indicate the end of the byte. For more information on start bits and stop bits, see “Serial Data Format” on page 13-11. The RS-232 standard also supports a synchronous mode where all transmitted bits are synchronized to a common clock signal.

At the hardware level, most serial ports operate asynchronously. However, using the default behavior for many of the read and write functions, you can mimic the operation of a synchronous serial port.

Note When used in this guide, the terms *synchronous* and *asynchronous* refer to whether read or write operations block access to the MATLAB command-line. In other words, these terms describe how the software behaves, and not how the hardware behaves.

The two main advantages of writing or reading data asynchronously are:

- You can issue another command while the write or read function is executing.
- You can use all supported callback properties (see “Events and Callbacks” on page 13-55).

For example, because serial ports have separate read and write pins, you can simultaneously read and write data. This is illustrated in the following diagram.

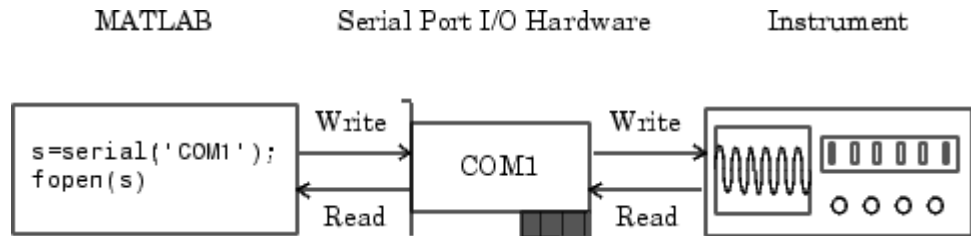

Writing Data

This section describes writing data to your serial port device in three parts:

- “The Output Buffer and Data Flow” on page 13-37 describes the flow of data from MATLAB software to the device.
- “Writing Text Data” on page 13-39 describes how to write text data (string commands) to the device.
- “Writing Binary Data” on page 13-41 describes how to write binary (numerical) data to the device.

The following table shows the functions associated with writing data.

Functions Associated with Writing Data

Function Name	Description
<code>fprintf</code>	Write text to the device
<code>fwrite</code>	Write binary data to the device
<code>stopasync</code>	Stop asynchronous read and write operations

The following table shows the properties associated with writing data.

Properties Associated with Writing Data

Property Name	Description
<code>BytesToOutput</code>	Number of bytes currently in the output buffer
<code>OutputBufferSize</code>	Size of the output buffer in bytes
<code>Timeout</code>	Waiting time to complete a read or write operation
<code>TransferStatus</code>	Indicate if an asynchronous read or write operation is in progress
<code>ValuesSent</code>	Total number of values written to the device

The Output Buffer and Data Flow

The output buffer is computer memory allocated by the serial port object to store data that is to be written to the device. When writing data to your device, the data flow follows these two steps:

- 1 The data specified by the write function is sent to the output buffer.
- 2 The data in the output buffer is sent to the device.

The `OutputBufferSize` property specifies the maximum number of bytes that you can store in the output buffer. The `BytesToOutput` property indicates the number of bytes currently in the output buffer. The default values for these properties are:

```
s = serial('COM1');
get(s,{'OutputBufferSize','BytesToOutput'})
```

```
ans =
     [512]     [0]
```

If you attempt to write more data than can fit in the output buffer, an error is returned and no data is written.

For example, suppose you write the string command `*IDN?` to the TDS 210 oscilloscope using the `fprintf` function. As shown in the following diagram, the string is first written to the output buffer as six values.

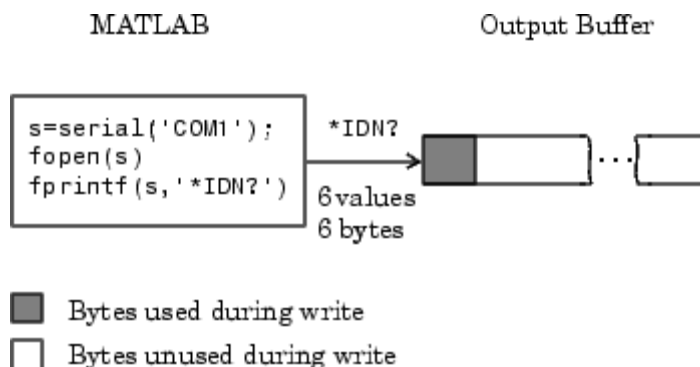

The `*IDN?` command consists of six values because the terminator is automatically written. Moreover, the default data format for the `fprintf` function specifies that one value corresponds to one byte. For more information about bytes and values, see “Bytes Versus Values” on page 13-12. `fprintf` and the terminator are discussed in “Writing Text Data” on page 13-39.

As shown in the following diagram, after the string is written to the output buffer, it is then written to the device via the serial port.

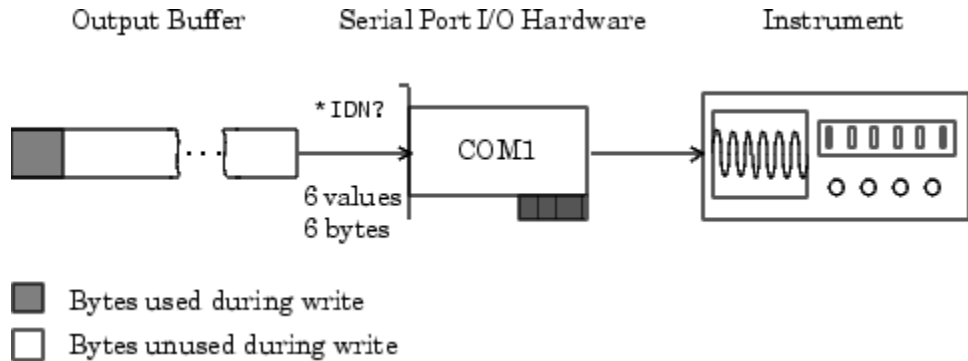

Writing Text Data

You use the `fprintf` function to write text data to the device. For many devices, writing text data means writing string commands that change device settings, prepare the device to return data or status information, and so on.

For example, the `Display:Contrast` command changes the display contrast of the oscilloscope.

```
s = serial('COM1');
fopen(s)
fprintf(s,'Display:Contrast 45')
```

By default, `fprintf` writes data using the `%s\n` format because many serial port devices accept only text-based commands. However, you can specify many other formats, as described in the `fprintf` reference pages.

You can verify the number of values sent to the device with the `ValuesSent` property.

```
s.ValuesSent
ans =
    20
```

Note that the `ValuesSent` property value includes the terminator because each occurrence of `\n` in the command sent to the device is replaced with the `Terminator` property value.

```
s.Terminator
```

```
ans =  
LF
```

The default value of `Terminator` is the linefeed character. The terminator required by your device will be described in its documentation.

Synchronous Versus Asynchronous Write Operations. By default, `fprintf` operates synchronously and blocks the MATLAB command line until execution completes. To write text data asynchronously to the device, you must specify `async` as the last input argument to `fprintf`.

```
fprintf(s,'Display:Contrast 45','async')
```

Asynchronous operations do not block access to the MATLAB command line. Additionally, while an asynchronous write operation is in progress, you can:

- Execute an asynchronous read operation because serial ports have separate pins for reading and writing
- Make use of all supported callback properties

You can determine which asynchronous operations are in progress with the `TransferStatus` property. If no asynchronous operations are in progress, `TransferStatus` is `idle`.

```
s.TransferStatus  
ans =  
idle
```

Completing a Write Operation with `fprintf`. A synchronous or asynchronous write operation using `fprintf` completes when:

- The specified data is written.
- The time specified by the `Timeout` property passes.

Stop an asynchronous write operation with the `stopasync` function.

Rules for Writing the Terminator. The `Terminator` property value replaces all occurrences of `\n` in `cmd`. Therefore, when you use the default format `%s\n`, all commands written to the device end with this property value. Refer to your device documentation for the terminator required by your device.

Writing Binary Data

You use the `fwrite` function to write binary data to the device. Writing binary data means writing numerical values. A typical application for writing binary data involves writing calibration data to an instrument such as an arbitrary waveform generator.

Note Some serial port devices accept only text-based commands. These commands might use the SCPI language or some other vendor-specific language. Therefore, you might need to use the `fprintf` function for all write operations.

By default, `fwrite` translates values using the `uchar` precision. However, you can specify many other precisions as described in the reference pages for this function.

By default, `fwrite` operates synchronously. To write binary data asynchronously to the device, you must specify `async` as the last input argument to `fwrite`. For more information about synchronous and asynchronous write operations, see “Writing Text Data” on page 13-39. For a description of the rules used by `fwrite` to complete a write operation, refer to its reference pages.

Troubleshooting Common Errors

Use this table to identify common `fprintf` errors.

Error	Occurs when	Troubleshooting
??? Error using ==> serial.fwrite at 199 OBJ must be connected to the hardware with FOPEN.	You perform a write operation and the serial port object is not connected to the device.	Use <code>fopen</code> to establish a connection to the device.
??? Error using ==> serial.fwrite at 199 The number of bytes	The output buffer is not able to hold all the data to be written.	Specify the size of the output buffer with

Error	Occurs when	Troubleshooting
written must be less than or equal to <code>OutputBufferSize-BytesToOutput</code> .		the <code>OutputBufferSize</code> property.
??? Error using ==> <code>serial.fwrite</code> at 192 <code>FWRITE</code> cannot be called. The <code>FlowControl</code> property is set to 'hardware' and the Clear To Send (CTS) pin is high. This could indicate that the serial device may not be turned on, may not be connected, or does not use hardware handshaking	<ul style="list-style-type: none"> • You set the <code>flowcontrol</code> property on a serial object to hardware. • The device is either not connected or a connected device is not asserting that is ready to receive data. 	Check your remote device status and flow control settings to see if hardware flow control is causing MATLAB errors.

Reading Data

This section describes reading data from your serial port device in three parts:

- “The Input Buffer and Data Flow” on page 13-43 describes the flow of data from the device to MATLAB software.
- “Reading Text Data” on page 13-45 describes how to read from the device, and format the data as text.
- “Reading Binary Data” on page 13-47 describes how to read binary (numerical) data from the device.

The following table shows the functions associated with reading data.

Functions Associated with Reading Data

Function Name	Description
fgetc	Read one line of text from the device and discard the terminator
fgets	Read one line of text from the device and include the terminator
fread	Read binary data from the device
fscanf	Read data from the device and format as text
readasync	Read data asynchronously from the device
stopasync	Stop asynchronous read and write operations

The following table shows the properties associated with reading data.

Properties Associated with Reading Data

Property Name	Description
BytesAvailable	Number of bytes available in the input buffer
InputBufferSize	Size of the input buffer in bytes
ReadAsyncMode	Specify whether an asynchronous read operation is continuous or manual
Timeout	Waiting time to complete a read or write operation
TransferStatus	Indicate if an asynchronous read or write operation is in progress
ValuesReceived	Total number of values read from the device

The Input Buffer and Data Flow

The input buffer is computer memory allocated by the serial port object to store data that is to be read from the device. When reading data from your device, the data flow follows these two steps:

- 1 The data read from the device is stored in the input buffer.

- 2** The data in the input buffer is returned to the MATLAB variable specified by the read function.

The `InputBufferSize` property specifies the maximum number of bytes that you can store in the input buffer. The `BytesAvailable` property indicates the number of bytes currently available to be read from the input buffer. The default values for these properties are:

```
s = serial('COM1');
get(s,{'InputBufferSize','BytesAvailable'})
ans =
    [512]    [0]
```

If you attempt to read more data than can fit in the input buffer, an error is returned and no data is read.

For example, suppose you use the `fscanf` function to read the text-based response of the `*IDN?` command previously written to the TDS 210 oscilloscope. As shown in the following diagram, the text data is first read into the input buffer via the serial port.

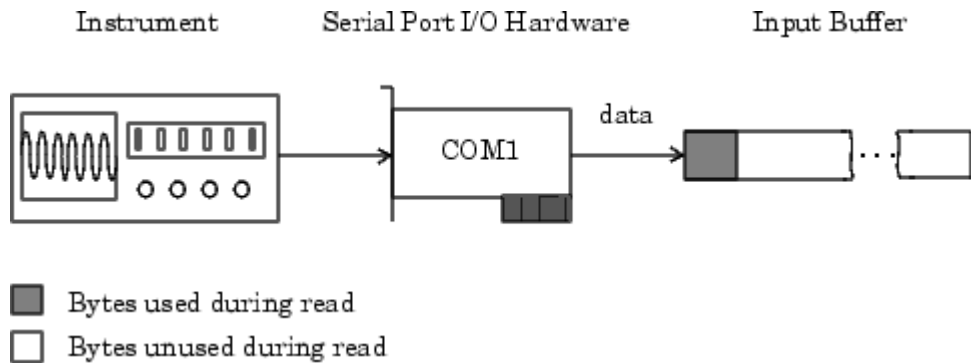

Note that for a given read operation, you might not know the number of bytes returned by the device. Therefore, you might need to preset the `InputBufferSize` property to a sufficiently large value before connecting the serial port object.

As shown in the following diagram, after the data is stored in the input buffer, it is then transferred to the output variable specified by `fscanf`.

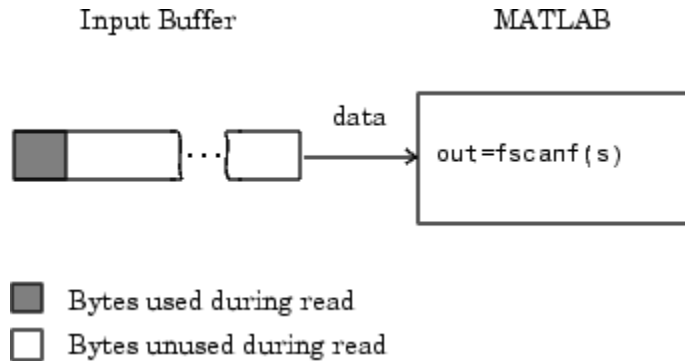

Reading Text Data

You use the `fgetl`, `fgets`, and `fscanf` functions to read data from the device, and format the data as text.

For example, suppose you want to return identification information for the oscilloscope. This requires writing the `*IDN?` command to the instrument, and then reading back the result of that command.

```
s = serial('COM1');
fopen(s)
fprintf(s, '*IDN?')
out = fscanf(s)
out =
TEKTRONIX,TDS 210,0,CF:91.1CT FV:v1.16 TDS2CM:CMV:v1.04
```

By default, `fscanf` reads data using the `%c` format because the data returned by many serial port devices is text based. However, you can specify many other formats as described in the `fscanf` reference pages.

You can verify the number of values read from the device—including the terminator—with the `ValuesReceived` property.

```
s.ValuesReceived
ans =
    56
```

Synchronous Versus Asynchronous Read Operations. You specify whether read operations are synchronous or asynchronous with the `ReadAsyncMode` property. You can configure `ReadAsyncMode` to `continuous` or `manual`.

If `ReadAsyncMode` is `continuous` (the default value), the serial port object continuously queries the device to determine if data is available to be read. If data is available, it is asynchronously stored in the input buffer. To transfer the data from the input buffer to MATLAB, use one of the synchronous (blocking) read functions such as `fgetl` or `fscanf`. If data is available in the input buffer, these functions return quickly.

```
s.ReadAsyncMode = 'continuous';
fprintf(s, '*IDN?')
s.BytesAvailable
ans =
    56
out = fscanf(s);
```

If `ReadAsyncMode` is `manual`, the serial port object does not continuously query the device to determine if data is available to be read. To read data asynchronously, use the `readasync` function. Then use one of the synchronous read functions to transfer data from the input buffer to MATLAB.

```
s.ReadAsyncMode = 'manual';
fprintf(s, '*IDN?')
s.BytesAvailable
ans =
    0
readasync(s)
s.BytesAvailable
ans =
    56
out = fscanf(s);
```

Asynchronous operations do not block access to the MATLAB command line. Additionally, while an asynchronous read operation is in progress, you can:

- Execute an asynchronous write operation because serial ports have separate pins for reading and writing

- Make use of all supported callback properties

You can determine which asynchronous operations are in progress with the `TransferStatus` property. If no asynchronous operations are in progress, then `TransferStatus` is `idle`.

```
s.TransferStatus
ans =
idle
```

Rules for Completing a Read Operation with `fscanf`. A read operation with `fscanf` blocks access to the MATLAB command line until:

- The terminator specified by the `Terminator` property is read.
- The time specified by the `Timeout` property passes.
- The specified number of values specified is read.
- The input buffer is filled.

Reading Binary Data

You use the `fread` function to read binary data from the device. Reading binary data means that you return numerical values to MATLAB.

For example, suppose you want to return the cursor and display settings for the oscilloscope. This requires writing the `CURSOR?` and `DISPLAY?` commands to the instrument, and then reading back the results of those commands.

```
s = serial('COM1');
fopen(s)
fprintf(s,'CURSOR?')
fprintf(s,'DISPLAY?')
```

Because the default value for the `ReadAsyncMode` property is `continuous`, data is asynchronously returned to the input buffer as soon as it is available from the device. You can verify the number of values read with the `BytesAvailable` property.

```
s.BytesAvailable
ans =
    69
```

You can return the data to MATLAB using any of the synchronous read functions. However, if you use `fgetl`, `fgets`, or `fscanf`, you must issue the function twice because there are two terminators stored in the input buffer. If you use `fread`, you can return all the data to MATLAB in one function call.

```
out = fread(s,69);
```

By default, `fread` returns numerical values in double precision arrays. However, you can specify many other precisions as described in the `fread` reference pages. You can convert the numerical data to text using the MATLAB `char` function.

```
val = char(out) '  
val =  
HBARS;CH1;SECONDS;-1.0E-3;1.0E-3;VOLTS;-6.56E-1;6.24E-1  
YT;DOTS;0;45
```

For more information about synchronous and asynchronous read operations, see “Reading Text Data” on page 13-45. For a description of the rules used by `fread` to complete a read operation, refer to its reference pages.

Example – Writing and Reading Text Data

This example illustrates how to communicate with a serial port instrument by writing and reading text data.

The instrument is a Tektronix TDS 210 two-channel oscilloscope connected to the COM1 port. Therefore, many of the following commands are specific to this instrument. A sine wave is input into channel 2 of the oscilloscope, and your job is to measure the peak-to-peak voltage of the input signal.

- 1** Create a serial port object — Create the serial port object `s` associated with serial port COM1.

```
s = serial('COM1');
```

- 2** Connect to the device — Connect `s` to the oscilloscope. Because the default value for the `ReadAsyncMode` property is `continuous`, data is asynchronously returned to the input buffer as soon as it is available from the instrument.

```
fopen(s)
```

- 3** Write and read data — Write the `*IDN?` command to the instrument using `fprintf`, and then read back the result of the command using `fscanf`.

```
fprintf(s, '*IDN?')
idn = fscanf(s)
idn =
TEKTRONIX,TDS 210,0,CF:91.1CT FV:v1.16 TDS2CM:CMV:v1.04
```

You need to determine the measurement source. Possible measurement sources include channel 1 and channel 2 of the oscilloscope.

```
fprintf(s, 'MEASUREMENT:IMMED:SOURCE?')
source = fscanf(s)
source =
CH1
```

The scope is configured to return a measurement from channel 1. Because the input signal is connected to channel 2, you must configure the instrument to return a measurement from this channel.

```
fprintf(s, 'MEASUREMENT:IMMED:SOURCE CH2')
fprintf(s, 'MEASUREMENT:IMMED:SOURCE?')
source = fscanf(s)
source =
CH2
```

You can now configure the scope to return the peak-to-peak voltage, and then request the value of this measurement.

```
fprintf(s, 'MEASUREMENT:MEAS1:TYPE PK2PK')
fprintf(s, 'MEASUREMENT:MEAS1:VALUE?')
```

Transfer data from the input buffer to MATLAB using `fscanf`.

```
ptop = fscanf(s, '%g')
ptop =
2.0199999809E0
```

- 4** Disconnect and clean up — When you no longer need `s` disconnect it from the instrument and remove it from memory and from the MATLAB workspace.

```
fclose(s)
delete(s)
clear s
```

Example — Parsing Input Data Using `textscan`

This example illustrates how to use the `textscan` function to parse and format data that you read from a device. `textscan` is particularly useful when you want to parse a string into one or more variables, where each variable has its own specified format.

The instrument is a Tektronix TDS 210 two-channel oscilloscope connected to the serial port COM1.

- 1** Create a serial port object — Create the serial port object `s` associated with serial port COM1.

```
s = serial('COM1');
```

- 2** Connect to the device — Connect `s` to the oscilloscope. Because the default value for the `ReadAsyncMode` property is `continuous`, data is asynchronously returned to the input buffer as soon as it is available from the instrument.

```
fopen(s)
```

- 3** Write and read data — Write the `RS232?` command to the instrument using `fprintf`, and then read back the result of the command using `fscanf`. `RS232?` queries the RS-232 settings and returns the baud rate, the software flow control setting, the hardware flow control setting, the parity type, and the terminator.

```
fprintf(s, 'RS232?')
data = fscanf(s)
data =
9600;0;0;NONE;LF
```

Use the `textscan` function to parse and format the data variable into five new variables.

```
C = textscan(a, '%d%d%d%s%s', 'delimiter', ';');

[br, sfc, hfc, par, tm] = deal(C{:});

br =
    9600
sfc =
    0
hfc =
    0
par =
    'NONE'
tm =
    'LF'
```

- 4** Disconnect and clean up — When you no longer need `s`, you should disconnect it from the instrument, and remove it from memory and from the MATLAB workspace.

```
fclose(s)
delete(s)
clear s
```

Example — Reading Binary Data

This example illustrates how you can download the TDS 210 oscilloscope screen display to MATLAB. The screen display data is transferred and saved to disk using the Windows bitmap format. This data provides a permanent record of your work, and is an easy way to document important signal and scope parameters.

Because the amount of data transferred is expected to be fairly large, it is asynchronously returned to the input buffer as soon as it is available from the instrument. This allows you to perform other tasks as the transfer progresses. Additionally, the scope is configured to its highest baud rate of 19,200.

- 1** Create a serial port object — Create the serial port object `s` associated with serial port COM1.

```
s = serial('COM1');
```

- 2** Configure property values — Configure the input buffer to accept a reasonably large number of bytes, and configure the baud rate to the highest value supported by the scope.

```
s.InputBufferSize = 50000;  
s.BaudRate = 19200;
```

- 3** Connect to the device — Connect `s` to the oscilloscope. Because the default value for the `ReadAsyncMode` property is `continuous`, data is asynchronously returned to the input buffer as soon as it is available from the instrument.

```
fopen(s)
```

- 4** Write and read data — Configure the scope to transfer the screen display as a bitmap.

```
fprintf(s,'HARDCOPY:PORT RS232')  
fprintf(s,'HARDCOPY:FORMAT BMP')  
fprintf(s,'HARDCOPY START')
```

Wait until all the data is sent to the input buffer, and then transfer the data to the MATLAB workspace as unsigned 8-bit integers.

```
out = fread(s,s.BytesAvailable,'uint8');
```

- 5** Disconnect and clean up — When you no longer need `s`, disconnect it from the instrument and remove it from memory and from the MATLAB workspace.

```
fclose(s)  
delete(s)  
clear s
```

Viewing the Bitmap Data

To view the bitmap data, follow these steps:

- 1** Open a disk file.

- 2** Write the data to the disk file.
- 3** Close the disk file.
- 4** Read the data into MATLAB using the `imread` function.
- 5** Scale and display the data using the `imagesc` function.

Note that the file I/O versions of the `fopen`, `fwrite`, and `fclose` functions are used.

```
fid = fopen('test1.bmp','w');
fwrite(fid,out,'uint8');
fclose(fid)
a = imread('test1.bmp','bmp');
imagesc(a)
```

Because the scope returns the screen display data using only two colors, an appropriate colormap is selected.

```
mymap = [0 0 0; 1 1 1];
colormap(mymap)
```

The following diagram shows the resulting bitmap image.

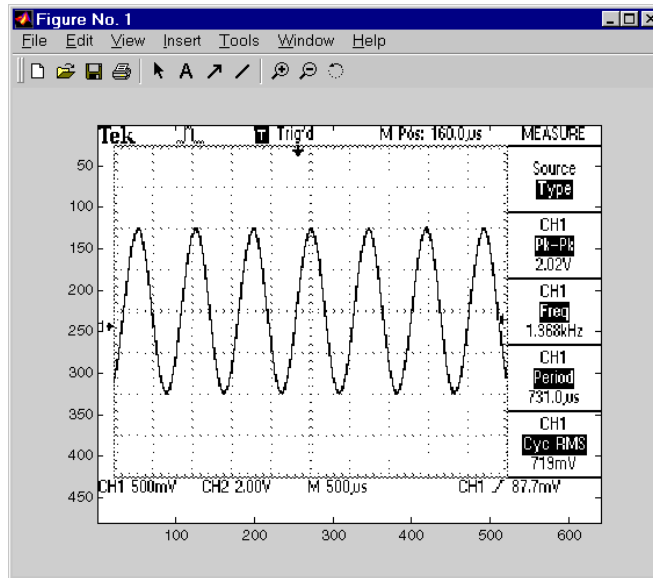

Events and Callbacks

In this section...

“Introduction” on page 13-55

“Example — Introduction to Events and Callbacks” on page 13-56

“Event Types and Callback Properties” on page 13-56

“Responding To Event Information” on page 13-59

“Creating and Executing Callback Functions” on page 13-61

“Enabling Callback Functions After They Error” on page 13-62

“Example — Using Events and Callbacks” on page 13-62

Introduction

You can enhance the power and flexibility of your serial port application by using *events*. An event occurs after a condition is met and might result in one or more callbacks.

While the serial port object is connected to the device, you can use events to display a message, display data, analyze data, and so on. Callbacks are controlled through *callback properties* and *callback functions*. All event types have an associated callback property. Callback functions are MATLAB functions that you construct to suit your specific application needs.

You execute a callback when a particular event occurs by specifying the name of the callback function as the value for the associated callback property.

Note All examples in this section are based on a Windows 32-bit platform. For information about other platforms refer to “Overview of a Serial Port Object” on page 13-27.

Example – Introduction to Events and Callbacks

This example uses the callback function `instrcallback` to display a message to the command line when a bytes-available event occurs. The event is generated when the terminator is read.

```
s = serial('COM1');  
fopen(s)  
s.BytesAvailableFcnMode = 'terminator';  
s.BytesAvailableFcn = @instrcallback;  
fprintf(s,'*IDN?')  
out = fscanf(s);
```

MATLAB displays:

```
BytesAvailable event occurred at 17:01:29 for the object:  
Serial-COM1.
```

End the serial port session.

```
fclose(s)  
delete(s)  
clear s
```

You can see the code for the built-in `instrcallback` function by using the `type` command.

Event Types and Callback Properties

The following table describes serial port event types and callback properties. This table has two columns and nine rows. In the first column (event type), the second item (bytes available) applies to rows 2 through 4. Also, in the first column the last item (timer) applies to rows 8 and 9.

Event Types and Callback Properties

Event Type	Associated Properties
Break interrupt	BreakInterruptFcn
Bytes available	BytesAvailableFcn
	BytesAvailableFcnCount
	BytesAvailableFcnMode
Error	ErrorFcn
Output empty	OutputEmptyFcn
Pin status	PinStatusFcn
Timer	TimerFcn
	TimerPeriod

Break-Interrupt Event

A break-interrupt event is generated immediately after a break interrupt is generated by the serial port. The serial port generates a break interrupt when the received data has been in an inactive state longer than the transmission time for one character.

This event executes the callback function specified for the `BreakInterruptFcn` property. It can be generated for both synchronous and asynchronous read and write operations.

Bytes-Available Event

A bytes-available event is generated immediately after a predetermined number of bytes are available in the input buffer or a terminator is read, as determined by the `BytesAvailableFcnMode` property.

If `BytesAvailableFcnMode` is `byte`, the bytes-available event executes the callback function specified for the `BytesAvailableFcn` property every time the number of bytes specified by `BytesAvailableFcnCount` is stored in the input buffer. If `BytesAvailableFcnMode` is `terminator`, the callback function executes every time the character specified by the `Terminator` property is read.

This event can be generated only during an asynchronous read operation.

Error Event

An error event is generated immediately after an error occurs.

This event executes the callback function specified for the `ErrorFcn` property. It can be generated only during an asynchronous read or write operation.

An error event is generated when a time-out occurs. A time-out occurs if a read or write operation does not successfully complete within the time specified by the `Timeout` property. An error event is not generated for configuration errors such as setting an invalid property value.

Output-Empty Event

An output-empty event is generated immediately after the output buffer is empty.

This event executes the callback function specified for the `OutputEmptyFcn` property. It can be generated only during an asynchronous write operation.

Pin Status Event

A pin status event is generated immediately after the state (pin value) changes for the CD, CTS, DSR, or RI pins. For a description of these pins, see “Serial Port Signals and Pin Assignments” on page 13-7.

This event executes the callback function specified for the `PinStatusFcn` property. It can be generated for both synchronous and asynchronous read and write operations.

Timer Event

A timer event is generated when the time specified by the `TimerPeriod` property passes. Time is measured relative to when the serial port object is connected to the device.

This event executes the callback function specified for the `TimerFcn` property. Note that some timer events might not be processed if your system is significantly slowed or if the `TimerPeriod` value is too small.

Responding To Event Information

You can respond to event information in a callback function or in a record file. Event information is stored in a callback function using two fields: `Type` and `Data`. The `Type` field contains the event type, while the `Data` field contains event-specific information. As described in “Creating and Executing Callback Functions” on page 13-61, these two fields are associated with a structure that you define in the callback function header. To learn about recording data and event information to a record file, see “Debugging: Recording Information to Disk” on page 13-71.

The following table shows event types and the values for the `Type` and `Data` fields. The table has three columns and 15 rows. Items in the first column (event type) span several rows, as follows:

Break interrupt: rows 1 and 2

Bytes available: rows 3 and 4

Error: rows 5 through 7

Output empty: rows 8 and 9

Pin status: rows 10 through 13

Timer: rows 14 and 15

Event Information

Event Type	Field	Field Value
Break interrupt	Type	BreakInterrupt
	Data.AbsTime	day-month-year hour:minute:second
Bytes available	Type	BytesAvailable
	Data.AbsTime	day-month-year hour:minute:second

Event Information (Continued)

Event Type	Field	Field Value
Error	Type	Error
	Data.AbsTime	day-month-year hour:minute:second
	Data.Message	An error string
Output empty	Type	OutputEmpty
	Data.AbsTime	day-month-year hour:minute:second
Pin status	Type	PinStatus
	Data.AbsTime	day-month-year hour:minute:second
	Data.Pin	CarrierDetect, ClearToSend, DataSetReady, or RingIndicator
	Data.PinValue	on or off
Timer	Type	Timer
	Data.AbsTime	day-month-year hour:minute:second

The following topics describe the Data field values.

The AbsTime Field

The AbsTime field, defined for all events, is the absolute time the event occurred. The absolute time is returned using the clock format: day-month-year hour:minute:second.

The Pin Field

The pin status event uses the Pin field to indicate if the CD, CTS, DSR, or RI pins changed state. For a description of these pins, see “Serial Port Signals and Pin Assignments” on page 13-7.

The PinValue Field

The pin status event uses the `PinValue` field to indicate the state of the CD, CTS, DSR, or RI pins. Possible values are `on` or `off`.

The Message Field

The error event uses the `Message` field to store the descriptive message that is generated when an error occurs.

Creating and Executing Callback Functions

You can specify the callback function to be executed when a specific event type occurs by including the name of the file as the value for the associated callback property. You can specify the callback function as a function handle or as a string cell array element. Function handles are described in the `function_handle` reference pages.

For example, to execute the callback function `mycallback` every time the terminator is read from your device:

```
s.BytesAvailableFcnMode = 'terminator';  
s.BytesAvailableFcn = @mycallback;
```

Alternatively, you can specify the callback function as a cell array.

```
s.BytesAvailableFcn = {'mycallback'};
```

Callback functions require at least two input arguments. The first argument is the serial port object. The second argument is a variable that captures the event information shown in the table, Event Information on page 13-59. This event information pertains only to the event that caused the callback function to execute. The function header for `mycallback` is:

```
function mycallback(obj,event)
```

You pass additional parameters to the callback function by including both the callback function and the parameters as elements of a cell array. For example, to pass the MATLAB variable `time` to `mycallback`:

```
time = datestr(now,0);  
s.BytesAvailableFcnMode = 'terminator';
```

```
s.BytesAvailableFcn = {@mycallback,time};
```

Alternatively, you can specify the callback function as a string in the cell array.

```
s.BytesAvailableFcn = {'mycallback',time};
```

The corresponding function header is:

```
function mycallback(obj,event,time)
```

If you pass additional parameters to the callback function, they must be included in the function header after the two required arguments.

Note You can also specify the callback function as a string. In this case, the callback is evaluated in the MATLAB workspace and no requirements are made on the input arguments of the callback function.

Enabling Callback Functions After They Error

If an error occurs while a callback function is executing the following occurs:

- The callback function is automatically disabled.
- A warning is displayed at the command line, indicating that the callback function is disabled.

If you want to enable the same callback function, set the callback property to the same value or disconnect the object with the `fclose` function. If you want to use a different callback function, the callback is enabled when you configure the callback property to the new value.

Example — Using Events and Callbacks

This example uses the callback function `instrcallback` to display event-related information to the command line when a bytes-available event or an output-empty event occurs.

- 1 Create a serial port object — Create the serial port object `s` associated with serial port COM1.

```
s = serial('COM1');
```

- 2** Configure properties — Configure `s` to execute the callback function `instrcallback` when a bytes-available event or an output-empty event occurs. Because `instrcallback` requires the serial port object and event information to be passed as input arguments, the callback function is specified as a function handle.

```
s.BytesAvailableFcnMode = 'terminator';
s.BytesAvailableFcn = @instrcallback;
s.OutputEmptyFcn = @instrcallback;
```

- 3** Connect to the device — Connect `s` to the Tektronix TDS 210 oscilloscope. Because the default value for the `ReadAsyncMode` property is `continuous`, data is asynchronously returned to the input buffer as soon as it is available from the instrument.

```
fopen(s)
```

- 4** Write and read data — Write the `RS232?` command asynchronously to the oscilloscope. This command queries the RS-232 settings and returns the baud rate, the software flow control setting, the hardware flow control setting, the parity type, and the terminator.

```
fprintf(s, 'RS232?', 'async')
```

`instrcallback` is called after the `RS232?` command is sent, and when the terminator is read. The resulting displays are:

```
OutputEmpty event occurred at 17:37:21 for the object:
Serial-COM1.
```

```
BytesAvailable event occurred at 17:37:21 for the object:
Serial-COM1.
```

Read the data from the input buffer.

```
out = fscanf(s)
out =
9600;0;0;NONE;LF
```

- 5 Disconnect and clean up — When you no longer need `s`, disconnect it from the instrument and remove it from memory and from the MATLAB workspace.

```
fclose(s)
delete(s)
clear s
```

Using Control Pins

In this section...

“Properties of Serial Port Control Pins” on page 13-65

“Signaling the Presence of Connected Devices” on page 13-65

“Controlling the Flow of Data: Handshaking” on page 13-68

Properties of Serial Port Control Pins

As described in “Serial Port Signals and Pin Assignments” on page 13-7, 9-pin serial ports include six control pins. The following table shows properties associated with the serial port control pins.

Control Pin Properties

Property Name	Description
DataTerminalReady	State of the DTR pin
FlowControl	Data flow control method to use
PinStatus	State of the CD, CTS, DSR, and RI pins
RequestToSend	State of the RTS pin

Signaling the Presence of Connected Devices

DTEs and DCEs often use the CD, DSR, RI, and DTR pins to indicate whether a connection is established between serial port devices. Once the connection is established, you can begin to write or read data.

You can monitor the state of the CD, DSR, and RI pins with the `PinStatus` property. You can specify or monitor the state of the DTR pin with the `DataTerminalReady` property.

The following example illustrates how these pins are used when two modems are connected to each other.

Note All examples in this section are based on a Windows 32-bit platform. For more information about other supported platforms, refer to “Overview of a Serial Port Object” on page 13-27.

Example – Connecting Two Modems

This example connects two modems to each other via the same computer, and illustrates how you can monitor the communication status for the computer-modem connections, and for the modem-modem connection. The first modem is connected to COM1, while the second modem is connected to COM2.

- 1** Create the serial port objects — After the modems are powered on, the serial port object `s1` is created for the first modem, and the serial port object `s2` is created for the second modem.

```
s1 = serial('COM1');  
s2 = serial('COM2');
```

- 2** Connect to the devices — `s1` and `s2` are connected to the modems. Because the default value for the `ReadAsyncMode` property is `continuous`, data is asynchronously returned to the input buffers as soon as it is available from the modems.

```
fopen(s1)  
fopen(s2)
```

Because the default `DataTerminalReady` property value is `on`, the computer (data terminal) is now ready to exchange data with the modems. You can verify that the modems (data sets) can communicate with the computer by examining the value of the Data Set Ready pin with the `PinStatus` property.

```
s1.Pinstatus  
ans =  
    CarrierDetect: 'off'  
    ClearToSend: 'on'  
    DataSetReady: 'on'  
    RingIndicator: 'off'
```

The value of the `DataSetReady` field is on because both modems were powered on before they were connected to the objects.

- 3** Configure properties — Both modems are configured for a baud rate of 2400 bits per second and a carriage return (CR) terminator.

```
s1.BaudRate = 2400;
s1.Terminator = 'CR';
s2.BaudRate = 2400;
s2.Terminator = 'CR';
```

- 4** Write and read data — Write the `atd` command to the first modem. This command puts the modem “off the hook,” which is equivalent to manually lifting a phone receiver.

```
fprintf(s1, 'atd')
```

Write the `ata` command to the second modem. This command puts the modem in “answer mode,” which forces it to connect to the first modem.

```
fprintf(s2, 'ata')
```

After the two modems negotiate their connection, verify the connection status by examining the value of the Carrier Detect pin using the `PinStatus` property.

```
s1.PinStatus
ans =
    CarrierDetect: 'on'
      ClearToSend: 'on'
    DataSetReady: 'on'
    RingIndicator: 'off'
```

Verify the modem-modem connection by reading the descriptive message returned by the second modem.

```
s2.BytesAvailable
ans =
    25
out = fread(s2,25);
char(out)
ans =
```

```
ata
CONNECT 2400/NONE
```

Now break the connection between the two modems by configuring the `DataTerminalReady` property to `off`. You can verify that the modems are disconnected by examining the Carrier Detect pin value.

```
s1.DataTerminalReady = 'off';
s1.PinStatus
ans =
    CarrierDetect: 'off'
      ClearToSend: 'on'
    DataSetReady: 'on'
    RingIndicator: 'off'
```

- 5** Disconnect and clean up — Disconnect the objects from the modems and remove the objects from memory and from the MATLAB workspace.

```
fclose([s1 s2])
delete([s1 s2])
clear s1 s2
```

Controlling the Flow of Data: Handshaking

Data flow control or *handshaking* is a method used for communicating between a DCE and a DTE to prevent data loss during transmission. For example, suppose your computer can receive only a limited amount of data before it must be processed. As this limit is reached, a handshaking signal is transmitted to the DCE to stop sending data. When the computer can accept more data, another handshaking signal is transmitted to the DCE to resume sending data.

If supported by your device, you can control data flow using one of these methods:

- Hardware handshaking
- Software handshaking

Note Although you might be able to configure your device for both hardware handshaking and software handshaking at the same time, MATLAB does not support this behavior.

You can specify the data flow control method with the `FlowControl` property. If `FlowControl` is hardware, hardware handshaking is used to control data flow. If `FlowControl` is software, software handshaking is used to control data flow. If `FlowControl` is none, no handshaking is used.

Hardware Handshaking

Hardware handshaking uses specific serial port pins to control data flow. In most cases, these are the RTS and CTS pins. Hardware handshaking using these pins is described in “The RTS and CTS Pins” on page 13-10.

If `FlowControl` is hardware, the RTS and CTS pins are automatically managed by the DTE and DCE. You can return the CTS pin value with the `PinStatus` property. Configure or return the RTS pin value with the `RequestToSend` property.

Note Some devices also use the DTR and DSR pins for handshaking. However, these pins are typically used to indicate that the system is ready for communication, and are not used to control data transmission. In MATLAB, hardware handshaking always uses the RTS and CTS pins.

If your device does not use hardware handshaking in the standard way, then you might need to manually configure the `RequestToSend` property. In this case, you should configure `FlowControl` to none. If `FlowControl` is hardware, then the `RequestToSend` value that you specify might not be honored. Refer to the device documentation to determine its specific pin behavior.

Software Handshaking

Software handshaking uses specific ASCII characters to control data flow. These characters, known as Xon and Xoff (or XON and XOFF), are described in the following table.

Software Handshaking Characters

Character	Integer Value	Description
Xon	17	Resume data transmission
Xoff	19	Pause data transmission

When using software handshaking, the control characters are sent over the transmission line the same way as regular data. Therefore, only the TD, RD, and GND pins are needed.

The main disadvantage of software handshaking is that Xon or Xoff characters are not writable while numerical data is being written to the device. This is because numerical data might contain a 17 or 19, which makes it impossible to distinguish between the control characters and the data. However, you can write Xon or Xoff while data is being asynchronously read from the device because you are using both the TD and RD pins.

Example: Using Software Handshaking

Suppose you want to use software flow control with the example described in “Example — Reading Binary Data” on page 13-51. To do this, you must configure the oscilloscope and serial port object for software flow control.

```
fprintf(s, 'RS232:SOFTF ON')  
s.FlowControl = 'software';
```

To pause data transfer, write the numerical value 19 to the device.

```
fwrite(s,19)
```

To resume data transfer, write the numerical value 17 to the device.

```
fwrite(s,17)
```

Debugging: Recording Information to Disk

In this section...

“Introduction” on page 13-71

“Recording Properties” on page 13-71

“Example: Introduction to Recording Information” on page 13-72

“Creating Multiple Record Files” on page 13-72

“Specifying a Filename” on page 13-73

“The Record File Format” on page 13-73

“Example: Recording Information to Disk” on page 13-74

Introduction

Recording information to disk provides a permanent record of your serial port session, and is an easy way to debug your application. While the serial port object is connected to the device, you can record the following information to a disk file:

- The number of values written to the device, the number of values read from the device, and the data type of the values
- Data written to the device, and data read from the device
- Event information

Recording Properties

You record information to a disk file with the `record` function. The following table shows the properties associated with recording information to disk.

Recording Properties

Property Name	Description
<code>RecordDetail</code>	Amount of information saved to a record file
<code>RecordMode</code>	Specify whether data and event information is saved to one record file or to multiple record files

Recording Properties (Continued)

Property Name	Description
RecordName	Name of the record file
RecordStatus	Indicate if data and event information are saved to a record file

Note All examples in this section are based on a Windows 32-bit platform. For more information about other supported platforms, refer to “Overview of a Serial Port Object” on page 13-27.

Example: Introduction to Recording Information

This example records the number of values written to and read from the device, and stores the information to the file `myfile.txt`.

```
s = serial('COM1');
fopen(s)
s.RecordName = 'myfile.txt';
record(s)
fprintf(s, '*IDN?')
idn = fscanf(s);
fprintf(s, 'RS232?')
rs232 = fscanf(s);
```

End the serial port session.

```
fclose(s)
delete(s)
clear s
```

You can use the `type` command to display `myfile.txt` at the command line.

Creating Multiple Record Files

When you initiate recording with the `record` function, the `RecordMode` property determines if a new record file is created or if new information is appended to an existing record file.

You can configure `RecordMode` to `overwrite`, `append`, or `index`. If `RecordMode` is `overwrite`, the record file is overwritten each time recording is initiated. If `RecordMode` is `append`, the new information is appended to the file specified by `RecordName`. If `RecordMode` is `index`, a different disk file is created each time recording is initiated. The rules for specifying a record filename are discussed in the next section.

Specifying a Filename

You specify the name of the record file with the `RecordName` property. You can specify any value for `RecordName` — including a directory path — provided the filename is supported by your operating system. Additionally, if `RecordMode` is `index`, the filename follows these rules:

- Indexed filenames are identified by a number. This number precedes the filename extension and is increased by 1 for successive record files.
- If no number is specified as part of the initial filename, the first record file does not have a number associated with it. For example, if `RecordName` is `myfile.txt`, `myfile.txt` is the name of the first record file, `myfile01.txt` is the name of the second record file, and so on.
- `RecordName` is updated after the record file is closed.
- If the specified filename already exists, the existing file is overwritten.

The Record File Format

The record file is an ASCII file that contains a record of one or more serial port sessions. You specify the amount of information saved to a record file with the `RecordDetail` property.

`RecordDetail` can be `compact` or `verbose`. A compact record file contains the number of values written to the device, the number of values read from the device, the data type of the values, and event information. A verbose record file contains the preceding information as well as the data transferred to and from the device.

Binary data with precision given by `uchar`, `schar`, `(u)int8`, `(u)int16`, or `(u)int32` is recorded using hexadecimal format. For example, if the integer value 255 is read from the instrument as a 16-bit integer, the hexadecimal value 00FF is saved in the record file. Single- and double-precision

floating-point numbers are recorded as decimal values using the %g format, and as hexadecimal values using the format specified by the IEEE® Standard 754-1985 for Binary Floating-Point Arithmetic.

The IEEE floating-point format includes three components: the sign bit, the exponent field, and the significant field. Single-precision floating-point values consist of 32 bits. The value is given by

$$\text{value} = (-1)^{\text{sign}} (2^{\text{exp}-127})(1.\text{significant})$$

Double-precision floating-point values consist of 64 bits. The value is given by

$$\text{value} = (-1)^{\text{sign}} (2^{\text{exp}-1023})(1.\text{significant})$$

The floating-point format component, and the associated single-precision and double-precision bits are shown in the following table.

Component	Single-Precision Bits	Double-Precision Bits
sign	1	1
exp	2–9	2–12
significant	10–32	13–64

Bit 1 is the left-most bit as stored in the record file.

Example: Recording Information to Disk

This example illustrates how to record information transferred between a serial port object and a Tektronix TDS 210 oscilloscope. Additionally, the structure of the resulting record file is presented.

- 1 Create the serial port object — Create the serial port object `s` associated with the serial port COM1.

```
s = serial('COM1');
```

- 2 Connect to the device — Connect `s` to the oscilloscope. Because the default value for the `ReadAsyncMode` property is `continuous`, data is

asynchronously returned the input buffer as soon as it is available from the instrument.

```
fopen(s)
```

- 3** Configure property values — Configure `s` to record information to multiple disk files using the verbose format. Recording is then initiated with the first disk file defined as `WaveForm1.txt`.

```
s.RecordMode = 'index';
s.RecordDetail = 'verbose';
s.RecordName = 'WaveForm1.txt';
record(s)
```

- 4** Write and read data — The commands written to the instrument, and the data read from the instrument are recorded in the record file. For an explanation of the oscilloscope commands, see “Example — Writing and Reading Text Data” on page 13-48.

```
fprintf(s, '*IDN?')
idn = fscanf(s);
fprintf(s, 'MEASUREMENT:IMMED:SOURCE CH2')
fprintf(s, 'MEASUREMENT:IMMED:SOURCE?')
source = fscanf(s);
```

Read the peak-to-peak voltage with the `fread` function. Note that the data returned by `fread` is recorded using hex format.

```
fprintf(s, 'MEASUREMENT:MEAS1:TYPE PK2PK')
fprintf(s, 'MEASUREMENT:MEAS1:VALUE?')
ptop = fread(s, s.BytesAvailable);
```

Convert the peak-to-peak voltage to a character array.

```
char(ptop) '
ans =
2.0199999809E0
```

The recording state is toggled from on to off. Because the `RecordMode` value is `index`, the record filename is automatically updated.

```
record(s)
```

```
s.RecordStatus
ans =
off
s.RecordName
ans =
WaveForm2.txt
```

- 5** Disconnect and clean up — When you no longer need `s`, disconnect it from the instrument, and remove it from memory and from the MATLAB workspace.

```
fclose(s)
delete(s)
clear s
```

The Record File Contents

The contents of the `WaveForm1.txt` record file are shown below. Because the `RecordDetail` property was `verbose`, the number of values, commands, and data were recorded. Note that data returned by the `fread` function is in hex format.

```
type WaveForm1.txt
```

Legend:

```
* - An event occurred.
> - A write operation occurred.
< - A read operation occurred.
1   Recording on 22-Jan-2000 at 11:21:21.575. Binary data in...
2   > 6 ascii values.
    *IDN?
3   < 56 ascii values.
    TEKTRONIX,TDS 210,0,CF:91.1CT FV:v1.16 TDS2CM:CMV:v1.04
4   > 29 ascii values.
    MEASUREMENT:IMMED:SOURCE CH2
5   > 26 ascii values.
    MEASUREMENT:IMMED:SOURCE?
6   < 4 ascii values.
    CH2
7   > 27 ascii values.
    MEASUREMENT:MEAS1:TYPE PK2PK
```



```
8 > 25 ascii values.  
   MEASUREMENT:MEAS1:VALUE?  
9 < 15 uchar values.  
   32 2e 30 31 39 39 39 39 39 38 30 39 45 30 0a  
10 Recording off.
```

Saving and Loading

In this section...

“Using save and load” on page 13-78

“Using Serial Port Objects on Different Platforms” on page 13-79

Using save and load

You can save serial port objects to a file, just as you would any workspace variable, using the `save` command. For example, suppose you create the serial port object `s` associated with the serial port COM1, configure several property values, and perform a write and read operation.

```
s = serial('COM1');
s.BaudRate = 19200;
s.Tag = 'My serial object';
fopen(s)
fprintf(s, '*IDN?')
out = fscanf(s);
```

To save the serial port object and the data read from the device to the file `myserial.mat`:

```
save myserial s out
```

Note You can save data and event information as text to a disk file with the `record` function.

You can recreate `s` and `out` in the workspace using the `load` command.

```
load myserial
```

Values for read only properties are restored to their default values upon loading. For example, the `Status` property is restored to `closed`. Therefore, to use `s`, you must connect it to the device with the `fopen` function. To determine if a property is read only, examine its reference pages.

Using Serial Port Objects on Different Platforms

If you save a serial port object from one platform, and then load that object on a different platform having different serial port names, you need to modify the `Port` property value. For example, suppose you create the serial port object `s` associated with the serial port `COM1` on a Microsoft Windows platform. If you want to save `s` for eventual use on a Linux platform, configure `Port` to an appropriate value such as `ttyS0` after the object is loaded.

Disconnecting and Cleaning Up

In this section...

“Disconnecting a Serial Port Object” on page 13-80

“Cleaning Up the MATLAB Environment” on page 13-80

Disconnecting a Serial Port Object

When you no longer need to communicate with the device, disconnect it from the serial port object with the `fclose` function.

```
fclose(s)
```

Examine the `Status` property to verify that the serial port object and the device are disconnected.

```
s.Status  
ans =  
closed
```

After `fclose` is issued, the serial port associated with `s` is available. Now connect another serial port object to it using `fopen`.

Cleaning Up the MATLAB Environment

When the serial port object is no longer needed, remove it from memory with the `delete` function.

```
delete(s)
```

Before using `delete`, disconnect the serial port object from the device with the `fclose` function.

A deleted serial port object is *invalid*, which means that you cannot connect it to the device. In this case, remove the object from the MATLAB workspace. To remove serial port objects and other variables from the MATLAB workspace, use the `clear` command.

```
clear s
```

Use `clear` on a serial port object that is still connected to a device to remove the object from the workspace but leave it connected to the device. Restore cleared objects to MATLAB with the `instrfind` function.

Property Reference

In this section...
“The Property Reference Page Format” on page 13-82
“Serial Port Object Properties” on page 13-82

The Property Reference Page Format

Each serial port property description contains some or all of this information:

- The property name
- A description of the property
- The property characteristics, including:
 - Read only — The condition under which the property is read only
A property can be read-only always, never, while the serial port object is open, or while the serial port object is recording. You can configure a property value using the `set` function or dot notation. You can return the current property value using the `get` function or dot notation.
 - Data type — the property data type
This is the data type you use when specifying a property value.
- Valid property values including the default value
When property values are given by a predefined list, the default value is usually indicated by `{}`.
- An example using the property
- Related properties and functions

Serial Port Object Properties

The serial port object properties are briefly described below, and organized into categories based on how they are used. Following this section the properties are listed alphabetically and described in detail.

Communications Properties	
BaudRate	Rate at which bits are transmitted
DataBits	Number of data bits to transmit
Parity	Type of parity checking
StopBits	Number of bits used to indicate the end of a byte
Terminator	Terminator character

Write Properties	
BytesToOutput	Number of bytes currently in the output buffer
OutputBufferSize	Size of the output buffer in bytes
Timeout	Waiting time to complete a read or write operation
TransferStatus	Indicate if an asynchronous read or write operation is in progress
ValuesSent	Total number of values written to the device

Read Properties	
BytesAvailable	Number of bytes available in the input buffer
InputBufferSize	Size of the input buffer in bytes
ReadAsyncMode	Specify whether an asynchronous read operation is continuous or manual
Timeout	Waiting time to complete a read or write operation
TransferStatus	Indicate if an asynchronous read or write operation is in progress
ValuesReceived	Total number of values read from the device

Callback Properties	
BreakInterruptFcn	Callback function to execute when a break-interrupt event occurs
BytesAvailableFcn	Callback function to execute when a specified number of bytes is available in the input buffer, or a terminator is read
BytesAvailableFcnCount	Number of bytes that must be available in the input buffer to generate a bytes-available event
BytesAvailableFcnMode	Specify if the bytes-available event is generated after a specified number of bytes is available in the input buffer, or after a terminator is read
ErrorFcn	Callback function to execute when an error event occurs
OutputEmptyFcn	Callback function to execute when the output buffer is empty
PinStatusFcn	Callback function to execute when the CD, CTS, DSR, or RI pins change state
TimerFcn	Callback function to execute when a predefined period of time passes
TimerPeriod	Period of time between timer events

Control Pin Properties	
DataTerminalReady	State of the DTR pin
FlowControl	Data flow control method to use
PinStatus	State of the CD, CTS, DSR, and RI pins
RequestToSend	State of the RTS pin

Recording Properties	
RecordDetail	Amount of information saved to a record file
RecordMode	Specify whether data and event information are saved to one record file or to multiple record files
RecordName	Name of the record file
RecordStatus	Indicate if data and event information are saved to a record file

General Purpose Properties	
ByteOrder	Order in which the device stores bytes
Name	Descriptive name for the serial port object
Port	Platform-specific serial port name
Status	Indicate if the serial port object is connected to the device
Tag	Label to associate with a serial port object
Type	Object type
UserData	Data you want to associate with a serial port object

Properties – Alphabetical List

Purpose Specify the rate at which bits are transmitted

Description You configure BaudRate as bits per second. The transferred bits include the start bit, the data bits, the parity bit (if used), and the stop bits. However, only the data bits are stored.

The baud rate is the rate at which information is transferred in a communication channel. In the serial port context, “9600 baud” means that the serial port is capable of transferring a maximum of 9600 bits per second. If the information unit is one baud (one bit), the bit rate and the baud rate are identical. If one baud is given as 10 bits, (for example, eight data bits plus two framing bits), the bit rate is still 9600 but the baud rate is 9600/10, or 960. You always configure BaudRate as bits per second. Therefore, in the previous example, set BaudRate to 9600.

Note Both the computer and the peripheral device must be configured to the same baud rate before you can successfully read or write data.

Standard baud rates include 110, 300, 600, 1200, 2400, 4800, 9600, 14400, 19200, 38400, 57600, 115200, 128000 and 256000 bits per second. To display the supported baud rates for the serial ports on your platform, see “Finding Serial Port Information for Your Platform” on page 13-16.

Characteristics

Read only	Never
Data type	Double

Values The default value is 9600.

See Also **Properties**

DataBits, Parity, StopBits

BreakInterruptFcn property

Purpose Specify the callback function to execute when a break-interrupt event occurs

Description You configure BreakInterruptFcn to execute a callback function when a break-interrupt event occurs. A break-interrupt event is generated by the serial port when the received data is in an off (space) state longer than the transmission time for one byte.

Note A break-interrupt event can be generated at any time during the serial port session.

If the RecordStatus property value is on, and a break-interrupt event occurs, the record file records this information:

- The event type as BreakInterrupt
- The time the event occurred using the format day-month-year hour:minute:second:millisecond

To learn how to create a callback function, see “Creating and Executing Callback Functions” on page 13-61.

Characteristics

Read only	Never
Data type	Callback function

Values The default value is an empty string.

See Also

Functions

record

Properties

RecordStatus

Purpose Specify the byte order of the device

Description You configure ByteOrder to be `littleEndian` or `bigEndian`. If ByteOrder is `littleEndian`, the device stores the first byte in the first memory address. If ByteOrder is `bigEndian`, the device stores the last byte in the first memory address.

For example, suppose the hexadecimal value `4F52` is to be stored in device memory. Because this value consists of two bytes, `4F` and `52`, two memory locations are used. Using big-endian format, `4F` is stored first in the lower storage address. Using little-endian format, `52` is stored first in the lower storage address.

Note You should configure ByteOrder to the appropriate value for your device before performing a read or write operation. Refer to your device documentation for information about the order in which it stores bytes.

Characteristics	Read only	Never
	Data type	String

Values	<code>{littleEndian}</code>	The byte order of the device is little-endian.
	<code>bigEndian</code>	The byte order of the device is big-endian.

See Also **Properties**

Status

BytesAvailable property

Purpose Number of bytes available in the input buffer

Description BytesAvailable indicates the number of bytes currently available to be read from the input buffer. The property value is continuously updated as the input buffer is filled, and is set to 0 after the fopen function is issued.

You can make use of BytesAvailable only when reading data asynchronously. This is because when reading data synchronously, control is returned to the MATLAB command line only after the input buffer is empty. Therefore, the BytesAvailable value is always 0. To learn how to read data asynchronously, see “Reading Text Data” on page 13-45.

The BytesAvailable value can range from zero to the size of the input buffer. Use the InputBufferSize property to specify the size of the input buffer. Use the ValuesReceived property to return the total number of values read.

Characteristics	Read only	Always
	Data type	Double

Values The default value is 0.

See Also **Functions**

fopen

Properties

InputBufferSize, TransferStatus, ValuesReceived

Purpose Specify the callback function to execute when a specified number of bytes is available in the input buffer, or a terminator is read

Description You configure BytesAvailableFcn to execute a callback function when a bytes-available event occurs. A bytes-available event occurs when the number of bytes specified by the BytesAvailableFcnCount property is available in the input buffer, or after a terminator is read, as determined by the BytesAvailableFcnMode property.

Note A bytes-available event can be generated only for asynchronous read operations.

If the RecordStatus property value is on, and a bytes-available event occurs, the record file records this information:

- The event type as BytesAvailable
- The time the event occurred using the format day-month-year hour:minute:second:millisecond

To learn how to create a callback function, see “Creating and Executing Callback Functions” on page 13-61.

Characteristics

Read only	Never
Data type	Callback function

Values

The default value is an empty string.

Example

Create the serial port object `s` for a Tektronix TDS 210 two-channel oscilloscope connected to the serial port COM1.

```
s = serial('COM1');
```

BytesAvailableFcn property

Configure `s` to execute the callback function `instrcallback` when 40 bytes are available in the input buffer.

```
s.BytesAvailableFcnCount = 40;  
s.BytesAvailableFcnMode = 'byte';  
s.BytesAvailableFcn = @instrcallback;
```

Connect `s` to the oscilloscope.

```
fopen(s)
```

Write the `*IDN?` command, which instructs the scope to return identification information. Because the default value for the `ReadAsyncMode` property is `continuous`, data is read as soon as it is available from the instrument.

```
fprintf(s, '*IDN?')
```

MATLAB displays:

```
BytesAvailable event occurred at 18:33:35 for the object:  
Serial-COM1.
```

56 bytes are read and `instrcallback` is called once. The resulting display is shown above.

```
s.BytesAvailable  
ans =  
    56
```

Suppose you remove 25 bytes from the input buffer and then issue the `MEASUREMENT?` command, which instructs the scope to return its measurement settings.

```
out = fscanf(s, '%c', 25);  
fprintf(s, 'MEASUREMENT?')
```

MATLAB displays:

```
BytesAvailable event occurred at 18:33:48 for the object:
```

Serial-COM1.

BytesAvailable event occurred at 18:33:48 for the object:
Serial-COM1.

There are now 102 bytes in the input buffer, 31 of which are left over from the *IDN? command. instrcallback is called twice—once when 40 bytes are available and once when 80 bytes are available.

```
s.BytesAvailable  
ans =  
    102
```

See Also

Functions

record

Properties

BytesAvailableFcnCount, BytesAvailableFcnMode, RecordStatus, Terminator, TransferStatus

BytesAvailableFcnCount property

Purpose Specify the number of bytes that must be available in the input buffer to generate a bytes-available event

Description You configure BytesAvailableFcnCount to the number of bytes that must be available in the input buffer before a bytes-available event is generated.

Use the BytesAvailableFcnMode property to specify whether the bytes-available event occurs after a certain number of bytes are available or after a terminator is read.

The bytes-available event executes the callback function specified for the BytesAvailableFcn property.

You can configure BytesAvailableFcnCount only when the object is disconnected from the device. You disconnect an object with the fclose function. A disconnected object has a Status property value of closed.

Characteristics

Read only	While open
Data type	Double

Values

The default value is 48.

See Also

Functions

fclose

Properties

BytesAvailableFcn, BytesAvailableFcnMode, Status

BytesAvailableFcnMode property

Purpose Specify if the bytes-available event is generated after a specified number of bytes is available in the input buffer, or after a terminator is read

Description You can configure BytesAvailableFcnMode to be terminator or byte. If BytesAvailableFcnMode is terminator, a bytes-available event occurs when the terminator specified by the Terminator property is reached. If BytesAvailableFcnMode is byte, a bytes-available event occurs when the number of bytes specified by the BytesAvailableFcnCount property is available.

The bytes-available event executes the callback function specified for the BytesAvailableFcn property.

You can configure BytesAvailableFcnMode only when the object is disconnected from the device. You disconnect an object with the fclose function. A disconnected object has a Status property value of closed.

Characteristics

Read only	While open
Data type	String

Values

{terminator}	A bytes-available event is generated when the terminator is read.
byte	A bytes-available event is generated when the specified number of bytes are available.

See Also

Functions

fclose

Properties

BytesAvailableFcn, BytesAvailableFcnCount, Status, Terminator

BytesToOutput property

Purpose Number of bytes currently in the output buffer

Description BytesToOutput indicates the number of bytes currently in the output buffer waiting to be written to the device. The property value is continuously updated as the output buffer is filled and emptied, and is set to 0 after the fopen function is issued.

You can make use of BytesToOutput only when writing data asynchronously. This is because when writing data synchronously, control is returned to the MATLAB command line only after the output buffer is empty. Therefore, the BytesToOutput value is always 0. To learn how to write data asynchronously, see “Writing Text Data” on page 13-39.

Use the ValuesSent property to return the total number of values written to the device.

Note If you attempt to write out more data than can fit in the output buffer, an error is returned and BytesToOutput is 0. Specify the size of the output buffer with the OutputBufferSize property.

Characteristics	Read only	Always
	Data type	Double

Values The default value is 0.

See Also **Functions**

fopen

Properties

OutputBufferSize, TransferStatus, ValuesSent

Purpose Number of data bits to transmit

Description You can configure DataBits to be 5, 6, 7, or 8. Data is transmitted as a series of five, six, seven, or eight bits with the least significant bit sent first. At least seven data bits are required to transmit ASCII characters. Eight bits are required to transmit binary data. Five and six bit data formats are used for specialized communications equipment.

Note Both the computer and the peripheral device must be configured to transmit the same number of data bits.

In addition to the data bits, the serial data format consists of a start bit, one or two stop bits, and possibly a parity bit. You specify the number of stop bits with the StopBits property, and the type of parity checking with the Parity property.

To display the supported number of data bits for the serial ports on your platform, see “Finding Serial Port Information for Your Platform” on page 13-16.

Characteristics

Read only	Never
Data type	Double

Values DataBits can be 5, 6, 7, or 8. The default value is 8.

See Also **Properties**

Parity, StopBits

DataTerminalReady property

Purpose State of the DTR pin

Description You can configure `DataTerminalReady` to be on or off. If `DataTerminalReady` is on, the Data Terminal Ready (DTR) pin is asserted. If `DataTerminalReady` is off, the DTR pin is unasserted.

In normal usage, the DTR and Data Set Ready (DSR) pins work together, and are used to signal if devices are connected and powered. However, there is nothing in the RS-232 standard that states the DTR pin must be used in any specific way. For example, DTR and DSR might be used for handshaking. You should refer to your device documentation to determine its specific pin behavior.

You can return the value of the DSR pin with the `PinStatus` property. Handshaking is described in “Controlling the Flow of Data: Handshaking” on page 13-68.

Characteristics	Read only	Never
	Data type	String

Values	{on}	The DTR pin is asserted.
	off	The DTR pin is unasserted.

See Also **Properties**
`FlowControl`, `PinStatus`

Purpose Specify the callback function to execute when an error event occurs

Description You configure ErrorFcn to execute a callback function when an error event occurs.

Note An error event is generated only for asynchronous read and write operations.

An error event is generated when a time-out occurs. A time-out occurs if a read or write operation does not successfully complete within the time specified by the Timeout property. An error event is not generated for configuration errors such as setting an invalid property value.

If the RecordStatus property value is on, and an error event occurs, the record file records this information:

- The event type as Error
- The error message
- The time the event occurred using the format day-month-year hour:minute:second:millisecond

To learn how to create a callback function, see “Creating and Executing Callback Functions” on page 13-61.

Characteristics

Read only	Never
Data type	Callback function

Values The default value is an empty string.

See Also **Functions**

record

ErrorFcn property

Properties

RecordStatus, Timeout

Purpose Data flow control method to use

Description You can configure `FlowControl` to be `none`, `hardware`, or `software`. If `FlowControl` is `none`, data flow control (handshaking) is not used. If `FlowControl` is `hardware`, hardware handshaking is used to control data flow. If `FlowControl` is `software`, software handshaking is used to control data flow.

Hardware handshaking typically utilizes the Request to Send (RTS) and Clear to Send (CTS) pins to control data flow. Software handshaking uses control characters (Xon and Xoff) to control data flow. For more information about handshaking, see “Controlling the Flow of Data: Handshaking” on page 13-68.

You can return the value of the CTS pin with the `PinStatus` property. You can specify the value of the RTS pin with the `RequestToSend` property. However, if `FlowControl` is `hardware`, and you specify a value for `RequestToSend`, that value might not be honored.

Note Although you might be able to configure your device for both hardware handshaking and software handshaking at the same time, MATLAB software does not support this behavior.

Characteristics	Read only	Never
	Data type	String

Values	{none}	No flow control is used.
	hardware	Hardware flow control is used.
	software	Software flow control is used.

FlowControl property

See Also

Properties

PinStatus, RequestToSend

Purpose Size of the input buffer in bytes

Description You configure `InputBufferSize` as the total number of bytes that can be stored in the input buffer during a read operation.

A read operation is terminated if the amount of data stored in the input buffer equals the `InputBufferSize` value. You can read text data with the `fgetl`, `fget`, or `fscanf` functions. You can read binary data with the `fread` function.

You can configure `InputBufferSize` only when the serial port object is disconnected from the device. You disconnect an object with the `fclose` function. A disconnected object has a `Status` property value of `closed`.

If you configure `InputBufferSize` while there is data in the input buffer, that data is flushed.

Characteristics

Read only	While open
Data type	Double

Values The default value is 512.

See Also

Functions

`fclose`, `fgetl`, `fgets`, `fopen`, `fread`, `fscanf`

Properties

`Status`

Name property

Purpose Descriptive name for the serial port object

Description You configure Name to be a descriptive name for the serial port object. When you create a serial port object, a descriptive name is automatically generated and stored in Name. This name is given by concatenating the word “Serial” with the serial port specified in the `serial` function. However, you can change the value of Name at any time. The serial port is given by the `Port` property. If you modify this property value, then Name is automatically updated to reflect that change.

Characteristics	Read only	Never
	Data type	String

Values Name is automatically defined when the serial port object is created.

Example Suppose you create a serial port object associated with the serial port COM1.

```
s = serial('COM1');
```

s is automatically assigned a descriptive name.

```
s.Name  
ans =  
Serial-COM1
```

See Also **Functions**
`serial`

Purpose Control access to serial port object

Description The ObjectVisibility property provides a way for application developers to prevent end-user access to the serial port objects created by their applications. When an object's ObjectVisibility property is set to `off`, `instrfind` does not return or delete that object.

Objects that are not visible are still valid. If you have access to the object (for example, from within the file that creates it), you can set and get its properties and pass it to any function that operates on serial port objects.

Characteristics

Usage	Any serial port object
Read only	Never
Data type	String

Values

<code>{on}</code>	Object is visible to <code>instrfind</code> .
<code>off</code>	Object is not visible from the command line (except by <code>instrfindall</code>).

Examples

The following statement creates a serial port object with its ObjectVisibility property set to `off`:

```
s = serial('COM1', 'ObjectVisibility', 'off');  
instrfind  
ans =  
    []
```

However, because the hidden object is in the workspace (`s`), you can access it.

```
get(s, 'ObjectVisibility')  
ans =  
    off
```

ObjectVisibility property

See Also

Functions

`instrfind`, `instrfindall`

Purpose Size of the output buffer in bytes

Description You configure `OutputBufferSize` as the total number of bytes that can be stored in the output buffer during a write operation.

An error occurs if the output buffer cannot hold all the data to be written. You write text data with the `fprintf` function. You write binary data with the `fwrite` function.

You can configure `OutputBufferSize` only when the serial port object is disconnected from the device. You disconnect an object with the `fclose` function. A disconnected object has a `Status` property value of `closed`.

Characteristics	Read only	While open
	Data type	Double

Values The default value is 512.

See Also **Functions**

`fprintf`, `fwrite`

Properties

`Status`

OutputEmptyFcn property

Purpose Specify the callback function to execute when the output buffer is empty

Description You configure OutputEmptyFcn to execute a callback function when an output-empty event occurs. An output-empty event is generated when the last byte is sent from the output buffer to the device.

Note An output-empty event can be generated only for asynchronous write operations.

If the RecordStatus property value is on, and an output-empty event occurs, the record file records this information:

- The event type as OutputEmpty
- The time the event occurred using the format day-month-year hour:minute:second:millisecond

To learn how to create a callback function, see “Creating and Executing Callback Functions” on page 13-61.

Characteristics

Read only	Never
Data type	Callback function

Values

The default value is an empty string.

See Also

Functions

record

Properties

RecordStatus

Purpose Specify the type of parity checking

Description You can configure `Parity` to be none, odd, even, mark, or space. If `Parity` is none, parity checking is not performed and the parity bit is not transmitted. If `Parity` is odd, the number of mark bits (1s) in the data is counted, and the parity bit is asserted or unasserted to obtain an odd number of mark bits. If `Parity` is even, the number of mark bits in the data is counted, and the parity bit is asserted or unasserted to obtain an even number of mark bits. If `Parity` is mark, the parity bit is asserted. If `Parity` is space, the parity bit is unasserted.

Parity checking can detect errors of one bit only. An error in two bits might cause the data to have a seemingly valid parity, when in fact it is incorrect. For more information about parity checking, see “The Parity Bit” on page 13-14.

In addition to the parity bit, the serial data format consists of a start bit, between five and eight data bits, and one or two stop bits. You specify the number of data bits with the `DataBits` property, and the number of stop bits with the `StopBits` property.

Characteristics	Read only	Never
	Data type	String

Values	{none}	No parity checking
	odd	Odd parity checking
	even	Even parity checking
	mark	Mark parity checking
	space	Space parity checking

See Also **Properties**

`DataBits`, `StopBits`

PinStatus property

Purpose State of the CD, CTS, DSR, and RI pins

Description PinStatus is a structure array that contains the fields CarrierDetect, ClearToSend, DataSetReady and RingIndicator. These fields indicate the state of the Carrier Detect (CD), Clear to Send (CTS), Data Set Ready (DSR) and Ring Indicator (RI) pins, respectively. For more information about these pins, see “Serial Port Signals and Pin Assignments” on page 13-7.

PinStatus can be on or off for any of these fields. A value of on indicates the associated pin is asserted. A value of off indicates the associated pin is unasserted. A pin status event occurs when any of these pins changes its state. A pin status event executes the call back function specified by PinStatusFcn.

In normal usage, the Data Terminal Ready (DTR) and DSR pins work together, while the Request to Send (RTS) and CTS pins work together. You can specify the state of the DTR pin with the DataTerminalReady property. You can specify the state of the RTS pin with the RequestToSend property.

For an example that uses PinStatus, see “Example — Connecting Two Modems” on page 13-66.

Characteristics	Read only	Always
	Data type	Structure

Values	off	The associated pin is unasserted.
	on	The associated pin is asserted.

The default value is device dependent.

See Also **Properties**

DataTerminalReady, PinStatusFcn, RequestToSend

Purpose Specify the callback function to execute when the CD, CTS, DSR, or RI pins change state

Description You configure PinStatusFcn to execute a callback function when a pin status event occurs. A pin status event occurs when the Carrier Detect (CD), Clear to Send (CTS), Data Set Ready (DSR) or Ring Indicator (RI) pin changes state. A serial port pin changes state when it is asserted or unasserted. Information about the state of these pins is recorded in the PinStatus property.

Note A pin status event can be generated at any time during the serial port session.

If the RecordStatus property value is on, and a pin status event occurs, the record file records this information:

- The event type as PinStatus
- The pin that changed its state, and the pin state as either on or off
- The time the event occurred using the format day-month-year hour:minute:second:millisecond

To learn how to create a callback function, see “Creating and Executing Callback Functions” on page 13-61.

Characteristics	Read only	Never
	Data type	Callback function

Values The default value is an empty string.

See Also **Functions**
record

PinStatusFcn property

Properties

PinStatus, RecordStatus

Purpose Specify the platform-specific serial port name

Description You configure `Port` to be the name of a serial port on your platform. `Port` specifies the physical port associated with the object and the device.

When you create a serial port object, `Port` is automatically assigned the port name specified for the `serial` function.

You can configure `Port` only when the object is disconnected from the device. You disconnect an object with the `fclose` function. A disconnected object has a `Status` property value of `closed`.

Characteristics	Read only	While open
	Data type	String

Values The `Port` value is determined when the serial port object is created.

Example Suppose you create a serial port object associated with serial port COM1.

```
s = serial('COM1');
```

The value of the `Port` property is COM1.

```
s.Port  
ans =  
COM1
```

See Also **Functions**

`fclose`, `serial`

Properties

`Name`, `Status`

ReadAsyncMode property

Purpose Specify whether an asynchronous read operation is continuous or manual

Description You can configure `ReadAsyncMode` to be `continuous` or `manual`. If `ReadAsyncMode` is `continuous`, the serial port object continuously queries the device to determine if data is available to be read. If data is available, it is automatically read and stored in the input buffer. If `readasync` is issued, the `readasync` function is ignored.

If `ReadAsyncMode` is `manual`, the object does not query the device to determine if data is available to be read. Instead, you must manually issue the `readasync` function to perform an asynchronous read operation. Because `readasync` checks for the terminator, this function can be slow. To increase speed, configure `ReadAsyncMode` to `continuous`.

Note If the device is ready to transmit data, it will do so regardless of the `ReadAsyncMode` value. Therefore, if `ReadAsyncMode` is `manual` and a read operation is not in progress, data might be lost. To guarantee that all transmitted data is stored in the input buffer, you should configure `ReadAsyncMode` to `continuous`.

You can determine the amount of data available in the input buffer with the `BytesAvailable` property. For either `ReadAsyncMode` value, you can bring data into the MATLAB workspace with one of the synchronous read functions such as `fscanf`, `fgetl`, `fgets`, or `fread`.

Characteristics

Read only	Never
Data type	String

ReadAsyncMode property

Values

{continuous}	Continuously query the device to determine if data is available to be read.
manual	Manually read data from the device using the readasync function.

See Also

Functions

fgetc1, fgets, fread, fscanf, readasync

Properties

BytesAvailable, InputBufferSize

RecordDetail property

Purpose Specify the amount of information saved to a record file

Description You can configure RecordDetail to be compact or verbose. If RecordDetail is compact, the number of values written to the device, the number of values read from the device, the data type of the values, and event information are saved to the record file. If RecordDetail is verbose, the data written to the device, and the data read from the device are also saved to the record file.

The event information saved to a record file is shown in the table, Event Information on page 13-59. The verbose record file structure is shown in “Example: Recording Information to Disk” on page 13-74.

Characteristics	Read only	Never
	Data type	String

Values	{compact}	The number of values written to the device, the number of values read from the device, the data type of the values, and event information are saved to the record file.
	verbose	The data written to the device, and the data read from the device are also saved to the record file.

See Also **Functions**

record

Properties

RecordMode, RecordName, RecordStatus

Purpose Specify whether data and event information are saved to one record file or to multiple record files

Description You can configure RecordMode to be overwrite, append, or index. If RecordMode is overwrite, the record file is overwritten each time recording is initiated. If RecordMode is append, data is appended to the record file each time recording is initiated. If RecordMode is index, a different record file is created each time recording is initiated, each with an indexed filename.

You can configure RecordMode only when the object is not recording. You terminate recording with the record function. A object that is not recording has a RecordStatus property value of off.

You specify the record filename with the RecordName property. The indexed filename follows a prescribed set of rules. For a description of these rules, see “Specifying a Filename” on page 13-73.

Characteristics

Read only	While recording
Data type	String

Values

{overwrite}	The record file is overwritten.
append	Data is appended to an existing record file.
index	A different record file is created, each with an indexed filename.

Example

Suppose you create the serial port object s associated with the serial port COM1.

```
s = serial('COM1');  
fopen(s)
```

Specify the record filename with the RecordName property, configure RecordMode to index, and initiate recording.

RecordMode property

```
s.RecordName = 'MyRecord.txt';  
s.RecordMode = 'index';  
record(s)
```

The record filename is automatically updated with an indexed filename after recording is turned off.

```
record(s, 'off')  
s.RecordName  
ans =  
MyRecord01.txt
```

Disconnect `s` from the peripheral device, remove `s` from memory, and remove `s` from the MATLAB workspace.

```
fclose(s)  
delete(s)  
clear s
```

See Also

Functions

`record`

Properties

`RecordDetail`, `RecordName`, `RecordStatus`

Purpose Name of the record file

Description You configure RecordName to be the name of the record file. You can specify any value for RecordName - including a directory path - provided the file name is supported by your operating system.

MATLAB software supports any file name supported by your operating system. However, if you access the file with a MATLAB command, you might need to specify the file name using single quotes. For example, suppose you name the record file My Record.txt. To type this file at the MATLAB command line, you must include the name in quotes.

```
type('My Record.txt')
```

You can specify whether data and event information are saved to one disk file or to multiple disk files with the RecordMode property. If RecordMode is index, the filename follows a prescribed set of rules. For a description of these rules, see “Specifying a Filename” on page 13-73.

You can configure RecordName only when the object is not recording. You terminate recording with the record function. An object that is not recording has a RecordStatus property value of off.

Characteristics

Read only	While recording
Data type	String

Values The default record filename is record.txt.

See Also

Functions

record

Properties

RecordDetail, RecordMode, RecordStatus

RecordStatus property

Purpose Indicate if data and event information are saved to a record file

Description You can configure RecordStatus to be off or on with the record function. If RecordStatus is off, then data and event information are not saved to a record file. If RecordStatus is on, then data and event information are saved to the record file specified by RecordName.

Use the record function to initiate or complete recording. RecordStatus is automatically configured to reflect the recording state.

For more information about recording to a disk file, see “Debugging: Recording Information to Disk” on page 13-71.

Characteristics	Read only	Always
	Data type	String

Values	{off}	Data and event information are not written to a record file.
	on	Data and event information are written to a record file.

See Also **Functions**

record

Properties

RecordDetail, RecordMode, RecordName

Purpose State of the RTS pin

Description You can configure RequestToSend to be on or off. If RequestToSend is on, the Request to Send (RTS) pin is asserted. If RequestToSend is off, the RTS pin is unasserted.

In normal usage, the RTS and Clear to Send (CTS) pins work together, and are used as standard handshaking pins for data transfer. In this case, RTS and CTS are automatically managed by the DTE and DCE. However, there is nothing in the RS-232 standard that requires the RTS pin must be used in any specific way. Therefore, if you manually configure the RequestToSend value, it is probably for nonstandard operations.

If your device does not use hardware handshaking in the standard way, and you need to manually configure RequestToSend, configure the FlowControl property to none. Otherwise, the RequestToSend value that you specify might not be honored. Refer to your device documentation to determine its specific pin behavior.

You can return the value of the CTS pin with the PinStatus property. Handshaking is described in “Controlling the Flow of Data: Handshaking” on page 13-68.

Characteristics	Read only	Never
	Data type	String

Values	{on}	The RTS pin is asserted.
	off	The RTS pin is unasserted.

See Also **Properties**
FlowControl, PinStatus

Status property

Purpose Indicate if the serial port object is connected to the device

Description Status can be open or closed. If Status is closed, the serial port object is not connected to the device. If Status is open, the serial port object is connected to the device.

Before you can write or read data, you must connect the serial port object to the device with the `fopen` function. Use the `fclose` function to disconnect a serial port object from the device.

Characteristics	Read only	Always
	Data type	String

Values	{closed}	The serial port object is not connected to the device.
	open	The serial port object is connected to the device.

See Also **Functions**
`fclose`, `fopen`

Purpose Number of bits used to indicate the end of a byte

Description You can configure StopBits to be 1, 1.5, or 2. If StopBits is 1, one stop bit is used to indicate the end of data transmission. If StopBits is 2, two stop bits are used to indicate the end of data transmission. If StopBits is 1.5, the stop bit is transferred for 150% of the normal time used to transfer one bit.

Note Both the computer and the peripheral device must be configured to transmit the same number of stop bits.

In addition to the stop bits, the serial data format consists of a start bit, between five and eight data bits, and possibly a parity bit. You specify the number of data bits with the DataBits property, and the type of parity checking with the Parity property.

Characteristics

Read only	Never
Data type	Double

Values

{1}	One stop bit is transmitted to indicate the end of a byte.
1.5	The stop bit is transferred for 150% of the normal time used to transfer one bit.
2	Two stop bits are transmitted to indicate the end of a byte.

See Also

Properties

DataBits, Parity

Tag property

Purpose Label to associate with a serial port object

Description You configure Tag to be a string value that uniquely identifies a serial port object.

Tag is particularly useful when constructing programs that would otherwise need to define the serial port object as a global variable, or pass the object as an argument between callback routines.

You can return the serial port object with the `instrfind` function by specifying the Tag property value.

Characteristics	Read only	Never
	Data type	String

Values The default value is an empty string.

Example Suppose you create a serial port object associated with the serial port COM1.

```
s = serial('COM1');  
fopen(s)
```

You can assign `s` a unique label using Tag.

```
set(s, 'Tag', 'MySerialObj')
```

You can access `s` in the MATLAB workspace or in a file using the `instrfind` function and the Tag property value.

```
s1 = instrfind('Tag', 'MySerialObj');
```

See Also **Functions**

`instrfind`

Purpose Terminator character

Description You can configure Terminator to an integer value ranging from 0 to 127, which represents the ASCII code for the character, or you can configure Terminator to the ASCII character. For example, to configure Terminator to a carriage return, specify the value to be CR or 13. To configure Terminator to a linefeed, specify the value to be LF or 10. You can also set Terminator to CR/LF or LF/CR. If Terminator is CR/LF, the terminator is a carriage return followed by a line feed. If Terminator is LF/CR, the terminator is a linefeed followed by a carriage return. Note that there are no integer equivalents for these two values. Additionally, you can set Terminator to a 1-by-2 cell array. The first element of the cell is the read terminator and the second element of the cell array is the write terminator.

When performing a write operation using the `fprintf` function, all occurrences of `\n` are replaced with the Terminator property value. Note that `%s\n` is the default format for `fprintf`. A read operation with `fgetl`, `fgets`, or `fscanf` completes when the Terminator value is read. The terminator is ignored for binary operations.

You can also use the terminator to generate a bytes-available event when the `BytesAvailableFcnMode` is set to `terminator`.

Characteristics	Read only	Never
	Data type	String

Values An integer value ranging from 0 to 127, or the equivalent ASCII character. CR/LF and LF/CR are also accepted values. You specify different read and write terminators as a 1-by-2 cell array.

See Also **Functions**

`fgetl`, `fgets`, `fprintf`, `fscanf`

Terminator property

Properties

BytesAvailableFcnMode

Purpose Waiting time to complete a read or write operation

Description You configure Timeout to be the maximum time (in seconds) to wait to complete a read or write operation.

If a time-out occurs, the read or write operation aborts. Additionally, if a time-out occurs during an asynchronous read or write operation, then:

- An error event is generated.
- The callback function specified for ErrorFcn is executed.

Characteristics

Read only	Never
Data type	Double

Values The default value is 10 seconds.

See Also **Properties**

ErrorFcn

TimerFcn property

Purpose Specify the callback function to execute when a predefined period of time passes.

Description You configure `TimerFcn` to execute a callback function when a timer event occurs. A timer event occurs when the time specified by the `TimerPeriod` property passes. Time is measured relative to when the serial port object is connected to the device with `fopen`.

Note A timer event can be generated at any time during the serial port session.

If the `RecordStatus` property value is on, and a timer event occurs, the record file records this information:

- The event type as `Timer`
- The time the event occurred using the format day-month-year hour:minute:second:millisecond

Some timer events might not be processed if your system is significantly slowed or if the `TimerPeriod` value is too small.

To learn how to create a callback function, see “Creating and Executing Callback Functions” on page 13-61.

Characteristics	Read only	Never
	Data type	Callback function

Values The default value is an empty string.

See Also **Functions**
`fopen`, `record`

Properties

RecordStatus, TimerPeriod

TimerPeriod property

Purpose Period of time between timer events

Description TimerPeriod specifies the time, in seconds, that must pass before the callback function specified for TimerFcn is called. Time is measured relative to when the serial port object is connected to the device with fopen.

Some timer events might not be processed if your system is significantly slowed or if the TimerPeriod value is too small.

Characteristics	Read only	Never
	Data type	Callback function

Values The default value is 1 second. The minimum value is 0.01 second.

See Also **Functions**

fopen

Properties

TimerFcn

Purpose Indicate if an asynchronous read or write operation is in progress

Description TransferStatus can be idle, read, write, or read&write. If TransferStatus is idle, no asynchronous read or write operations are in progress. If TransferStatus is read, an asynchronous read operation is in progress. If TransferStatus is write, an asynchronous write operation is in progress. If TransferStatus is read&write, both an asynchronous read and an asynchronous write operation are in progress.

You can write data asynchronously using the `fprintf` or `fwrite` functions. You can read data asynchronously using the `readasync` function, or by configuring the `ReadAsyncMode` property to `continuous`. While `readasync` is executing, `TransferStatus` might indicate that data is being read even though data is not filling the input buffer. If `ReadAsyncMode` is `continuous`, `TransferStatus` indicates that data is being read only when data is actually filling the input buffer.

You can execute an asynchronous read and an asynchronous write operation simultaneously because serial ports have separate read and write pins. For more information about synchronous and asynchronous read and write operations, see “Writing and Reading Data” on page 13-34.

Characteristics

Read only	Always
Data type	String

Values

{idle}	No asynchronous operations are in progress.
read	An asynchronous read operation is in progress.

TransferStatus property

write	An asynchronous write operation is in progress.
read&write	Asynchronous read and write operations are in progress.

See Also

Functions

fprintf, fwrite, readasync

Properties

ReadAsyncMode

Purpose Object type

Description Type indicates the type of the object. Type is automatically defined after the serial port object is created with the serial function. The Type value is always serial.

Characteristics	Read only	Always
	Data type	String

Values Type is always serial. This value is automatically defined when the serial port object is created.

Example Suppose you create a serial port object associated with the serial port COM1.

```
s = serial('COM1');
```

The value of the Type property is serial, which is the object class.

```
s.Type  
ans =  
serial
```

You can also display the object class with the whos command.

```
Name      Size      Bytes  Class  
  
s          1x1          644  serial object
```

Grand total is 18 elements using 644 bytes

See Also **Functions**

serial

UserData property

Purpose Data you want to associate with a serial port object

Description You configure `UserData` to store data that you want to associate with a serial port object. The object does not use this data directly, but you can access it using the `get` function or the dot notation.

Characteristics	Read only	Never
	Data type	Any type

Values The default value is an empty vector.

Example Suppose you create the serial port object associated with the serial port COM1.

```
s = serial('COM1');
```

You can associate data with `s` by storing it in `UserData`.

```
coeff.a = 1.0;  
coeff.b = -1.25;  
s.UserData = coeff;
```

Purpose Total number of values read from the device

Description ValuesReceived indicates the total number of values read from the device. The value is updated after each successful read operation, and is set to 0 after the fopen function is issued. If the terminator is read from the device, then this value is reflected by ValuesReceived.

If you are reading data asynchronously, use the BytesAvailable property to return the number of bytes currently available in the input buffer.

When performing a read operation, the received data is represented by values rather than bytes. A value consists of one or more bytes. For example, one uint32 value consists of four bytes. For more information about bytes and values, see “Bytes Versus Values” on page 13-12.

Characteristics	Read only	Always
	Data type	Double

Values The default value is 0.

Example Suppose you create a serial port object associated with the serial port COM1.

```
s = serial('COM1');  
fopen(s)
```

If you write the RS232? command, and read back the response using fscanf, ValuesReceived is 17 because the instrument is configured to send the LF terminator.

```
fprintf(s, 'RS232?')  
out = fscanf(s)  
out =  
9600;0;0;NONE;LF  
s.ValuesReceived
```

ValuesReceived property

```
ans =  
    17
```

See Also

Functions

fopen

Properties

BytesAvailable

Purpose Total number of values written to the device

Description ValuesSent indicates the total number of values written to the device. The value is updated after each successful write operation, and is set to 0 after the fopen function is issued. If you are writing the terminator, ValuesSent reflects this value.

If you are writing data asynchronously, use the BytesToOutput property to return the number of bytes currently in the output buffer.

When performing a write operation, the transmitted data is represented by values rather than bytes. A value consists of one or more bytes. For example, one uint32 value consists of four bytes. For more information about bytes and values, see “Bytes Versus Values” on page 13-12.

Characteristics

Read only	Always
Data type	Double

Values The default value is 0.

Example Suppose you create a serial port object associated with the serial port COM1.

```
s = serial('COM1');  
fopen(s)
```

If you write the *IDN? command using the fprintf function, ValuesSent is 6 because the default data format is %s\n, and the terminator was written.

```
fprintf(s, '*IDN?')  
s.ValuesSent  
ans =  
    6
```

ValuesSent property

See Also

Functions

fopen

Properties

BytesToOutput

A

API

- matrix access methods 3-3
- memory management 3-97
- mex functions 3-3
- argument checking 4-12
- argument passing, from Java methods
 - data conversion 7-59
 - built-in types 7-60
 - conversions you can perform 7-61
 - Java objects 7-60
- argument passing, to Java methods
 - data conversion 7-48
 - built-in arrays 7-50
 - built-in types 7-50
 - Java object arrays 7-54
 - Java object cell arrays 7-55
 - Java objects 7-52
 - objects of Object class 7-53
 - string arrays 7-52
 - string types 7-51
 - effect of dimension on 7-55
- argument type, Java
 - effect on method dispatching 7-56
- array access methods
 - mat 1-2
- arrays
 - cell 3-22
 - empty 3-23
 - MATLAB 3-18
 - multidimensional 3-23
 - persistent 4-48
 - serial port object 13-30
 - sparse 4-27
 - temporary 4-47 5-30
- arrays, Java
 - accessing elements of 7-37
 - assigning
 - the empty matrix 7-43
 - values to 7-41

- with single subscripts 7-42
 - comparison with MATLAB arrays 7-32
 - concatenation of 7-44
 - creating a copy 7-46
 - creating a reference 7-46
 - creating in MATLAB 7-35
 - creating with javaArray 7-35
 - dimensionality of 7-31
 - dimensions 7-34
 - indexing 7-32
 - with colon operator 7-39
 - with single subscripts 7-38 to 7-39
 - linear arrays 7-42
 - passed by reference 7-51
 - representing in MATLAB 7-30
 - sizing 7-33
 - subscripted deletion 7-43
 - using the end subscript 7-40
- ASCII file mode 1-7
- automation
 - client 10-76
 - controller 9-35 11-2
 - server 11-2

B

- BaudRate 13-87
- binary data
 - reading from a device 13-47
 - writing to a device 13-41
- binary file mode 1-7
- BreakInterruptFcn 13-88
- BSTR 11-11
- buffer
 - input, serial port object 13-43
 - output, serial port object 13-37
- ByteOrder 13-89
- BytesAvailable 13-90
- BytesAvailableFcn 13-91
- BytesAvailableFcnCount 13-94

BytesAvailableFcnMode 13-95

BytesToOutput 13-96

C

C example

convec.c 4-23

doubleelem.c 4-24

findnz.c 4-25

fulltosparse.c 4-27

phonebook.c 4-18

revord.c 4-14

sincall.c 4-28

timestwo.c 4-12

timestwoalt.c 4-13

xtimesy.c 4-17

C language

debugging 4-32

C language example

basic 4-12

calling MATLAB functions 4-28

calling user-defined functions 4-28

handling sparse arrays 4-27

persistent array 4-48

C/C++ language

data types 3-23

MEX-files 4-1

C/C++ language example

handling 8-, 16-, 32-bit data 4-24

handling arrays 4-25

handling complex data 4-23

passing multiple values 4-16

prompting user for input 4-22

strings 4-14

callback

serial port object 13-55

functions 13-61

properties 13-56

caller workspace 3-17

cat

using with Java arrays 7-44

using with Java objects 7-16

cell

using with Java objects 7-63

cell arrays 3-22 4-18

converting from Java object 7-63

char

overloading toChar in Java 7-62

class

using in Java 7-20

classes, Java 7-4

built-in 7-4

defining 7-5

identifying using which 7-26

importing 7-10

loading into workspace 7-10

making available to MATLAB 7-8

sources for 7-4

third-party 7-4

user-defined 7-4

classpath.txt

using with Java archive files 7-9

using with Java packages 7-8

colon

using in Java array access 7-39

using in Java array assignment 7-43

COM

Automation server 11-2

concepts 9-3

controller 11-2

event handler function 10-54

launching server 11-16

MATLAB as automation client 10-76

ProgID 9-4 10-8 to 10-10

server 11-2

use in the MATLAB engine 6-5

commands. *See* individual commands. 4-2 5-2

compiler

debugging

Microsoft 4-32

- selecting on Windows 3-28
 - supported 3-27
 - compiling
 - MAT-file application
 - UNIX 1-22
 - Windows 1-23
 - complex data
 - in Fortran 5-19
 - comopts.bat 3-55
 - computational routine 4-2 5-2 5-5
 - accessing mxArray data 4-5
 - concatenation
 - of Java arrays 7-44
 - of Java objects 7-16
 - configuration
 - problems 3-92
 - UNIX 3-33
 - Windows 3-28
 - control pins
 - serial port object, using 13-65
 - convec.c 4-23
 - convec.F 5-19
 - conversion, data
 - in Java method arguments 7-48
 - copying a Java array 7-46
- D**
- data access
 - within Java objects 7-18
 - data bits 13-14
 - data format
 - serial port 13-11
 - data storage 3-20
 - data type 4-11
 - C language 3-23
 - cell arrays 3-22
 - checking 4-12
 - complex double-precision nonsparse matrix 3-21
 - empty arrays 3-23
 - Fortran language 3-23
 - MATLAB 3-23
 - MATLAB string 3-22
 - multidimensional arrays 3-23
 - numeric matrix 3-22
 - objects 3-22
 - sparse arrays 4-27
 - sparse matrices 3-23
 - structures 3-22
 - data, MATLAB 3-18
 - importing to 1-8
 - DataBits 13-97
 - DataTerminalReady 13-98
 - dblmat.F 5-20
 - DCE 13-6
 - DCOM (distributed component object model) 11-13
 - using MATLAB as a server 11-13
 - debugging C/C++ language MEX-files 4-32
 - Linux 4-40
 - Windows 4-32
 - debugging Fortran language MEX-files
 - Linux 5-24
 - Windows 5-24
 - directory organization
 - MAT-file application 1-5
 - display
 - serial port object 13-29
 - display function
 - overloading toString in Java 7-27
 - documenting MEX-file 3-17
 - double
 - overloading toDouble in Java 7-61
 - doubleelem.c 4-24
 - DTE 13-6
 - dynamic memory allocation
 - in Fortran 5-20
 - mxMalloc 4-14

E

- empty arrays 3-23
- empty matrix
 - conversion to Java NULL 7-56
 - in Java array assignment 7-43
- empty string
 - conversion to Java object 7-56
- end
 - use with Java arrays 7-40
- eng_mat folder 6-6
- engClose 6-4
- engdemo.c 6-6
- engdemo.cpp 6-8
- engEvalString 6-4
- engGetVariable 6-4
- engGetVisible 6-4
- engine
 - compiling on UNIX 6-17
 - compiling on Windows 6-14
 - linking on UNIX 6-17
 - linking on Windows 6-14
- engine example
 - calling MATLAB
 - from C program 6-6
 - from Fortran program 6-9
- engine functions 6-4
- engine library 6-1
 - communicating with MATLAB
 - UNIX 6-5
 - Windows 6-5
- engOpen 6-4
- engOpenSingleUse 6-4
- engOutputBuffer 6-4
- engPutVariable 6-4
- engSetVisible 6-4
- engwindemo.c 1-16 6-6
- ErrorFcn 13-99
- event handler
 - function 10-54
 - writing 10-54

- events
 - serial port object 13-55
 - storing information 13-59
 - types 13-56
- examples, Java programming
 - creating and using a phone book 7-71
 - finding an internet protocol address 7-69
 - reading a URL 7-66
- exceptions, Java
 - handling 7-29
- explore example 3-24
- extension
 - MEX-file 3-16
- external libraries
 - data conversion 2-22
 - multilevel pointers 2-50
 - pointers 2-39
 - primitive types 2-18
 - structures 2-53
- library functions
 - getting information about 2-5
 - invoking functions 2-8
 - passing arguments 2-18
 - passing arguments:general rules 2-20
 - passing arguments:pointers 2-39
 - passing libstruct objects 2-53
- loading the library 2-4
- MATLAB interface to 2-1
- unloading the library 2-4
- using a compiler 2-4

F

- f option 3-32 3-35
- fengdemo.F 6-9
- fieldnames
 - using with Java objects 7-18
- file mode
 - ASCII 1-7
 - binary 1-7

- files
 - linking multiple 3-36
 - findnz.c 4-25
 - FlowControlHardware 13-101
 - folder
 - mex 3-3
 - refbook 4-11
 - folder path
 - convention 3-24
 - Fortran
 - data types 3-23
 - pointers
 - concept 5-16
 - declaring 5-5
 - Fortran examples
 - convec.F 5-19
 - dblmat.F 5-20
 - fulltospars.F 5-21
 - matsq.F 5-16
 - matsqint8.F 5-17
 - passstr.F 5-15
 - revord.F 5-14
 - sincall.F 5-22
 - timestwo.F 5-13
 - xtimesy.F 5-18
 - Fortran language examples
 - calling MATLAB functions 5-22
 - handling complex data 5-19
 - handling sparse matrices 5-21
 - passing arrays of strings 5-15
 - passing integers 5-17
 - passing matrices 5-16
 - passing multiple values 5-18
 - passing scalar 4-12 5-13
 - passing strings 5-14
 - Fortran language MEX-files 5-2
 - components 5-2
 - fulltospars.c 4-27
 - fulltospars.F 5-21
 - function handles
 - serial port object callback 13-61
- G**
- g option 4-32
 - gateway routine 4-2 5-2
 - accessing mxArray data 4-2 5-2
- H**
- handshaking
 - serial port object 13-68
 - help 3-17
 - help files 3-17
- I**
- IDE
 - building MEX-files 3-43
 - import
 - using with Java classes 7-10
 - include folder 1-5
 - indexing Java arrays
 - using single colon subscripting 7-39
 - using single subscripting 7-38
 - InputBufferSize 13-103
 - internet protocol address
 - Java example 7-69
 - ir 3-23 4-27 5-21
 - isa
 - using with Java objects 7-20
 - isjava
 - using with Java objects 7-20
- J**
- Java
 - API class packages 7-2
 - archive (JAR) files 7-9
 - development kit 7-5
 - Java Virtual Machine (JVM) 7-2

- packages 7-8
- Java, MATLAB interface to
 - arguments passed to Java methods 7-48
 - arguments returned from Java methods 7-59
 - arrays, working with 7-30
 - benefits of 7-2
 - classes, using 7-4
 - methods, invoking 7-21
 - objects, creating and using 7-13
 - overview 7-2
- javaArray function 7-35
- jc 3-23 4-27 5-21

L

- library
 - matrix 3-3
 - mx 3-3
- library path
 - setting on UNIX 1-22
- linking DLL files to MEX-files 3-54
- linking multiple files 3-36
- load
 - using with Java objects 7-17
- loading
 - serial port objects 13-78

M

- macros
 - accessing mxArray data 4-5 5-5

MAT-file

- C language
 - reading 1-15
- compiling 1-22
- examples 1-6
- Fortran language
 - creating 1-16
 - reading 1-17
- linking 1-22

- subroutines 1-4
- UNIX libraries 1-6
 - using 1-2
- Windows libraries 1-6

MAT-file application

- UNIX 1-22
- Windows 1-24

MAT-file example

- creating
 - C language 1-13
 - C++ language 1-14
 - Fortran language 1-16
- reading
 - C language 1-15
 - Fortran language 1-17

MAT-functions 1-4

- mat.h 1-5
- matClose 1-4
- matDeleteVariable 1-4
- matdemo1.f 1-16
- matdemo2.f 1-17
- matGetDir 1-4
- matGetFp 1-5
- matGetNextVariable 1-4
- matGetNextVariableInfo 1-4
- matGetVariable 1-4
- matGetVariableInfo 1-4

MATLAB

- arrays 3-18
- data 3-18
- data file format 1-2
- data storage 3-20
- data type 3-23
- engine 6-1
- importing data 1-8
- MAT-file 1-2
 - saving arrays to 1-8
- moving data between platforms 1-6 to 1-7
- standalone applications 1-2
- string 3-22

- using as a computation engine 6-1
 - variables 3-18
- matOpen 1-4
- matPutVariable 1-4
- matPutVariableAsGlobal 1-4
- matrix
 - complex double-precision nonsparse 3-21
 - numeric 3-22
 - sparse 3-23 5-21
- matrix.h 1-5
- matsq.F 5-16
- matsqint8.F 5-17
- memory
 - allocation 4-14
 - leak 3-100 4-48
 - temporary 5-30
- memory management 3-97 4-47 5-30
 - API 3-97
 - compatibility 3-97
 - routines 3-3
 - special considerations 4-47
- methods
 - using with Java methods 7-25
- methods, Java
 - converting input arguments 7-48
 - displaying 7-25
 - displaying information about 7-23
 - finding the defining class 7-26
 - overloading 7-56
 - passing data to 7-48
 - undefined 7-28
- methodsview 7-23
 - output fields 7-24
- mex
 - g 4-32
- mex build script 3-43 4-12
 - default options file, UNIX 3-49
 - default options file, Windows 3-54
 - switches 3-44
 - arch 3-44
 - c 3-44
 - compatibleArrayDims 3-44
 - cxx 3-44
 - Dname 3-44
 - Dname=value 3-45
 - f optionsfile 3-45
 - fortran 3-45
 - g 3-45
 - h[elp] 3-45
 - inline 3-45
 - Ipathname 3-45
 - largeArrayDims 3-46
 - Lfolder 3-46
 - lname 3-45
 - n 3-46
 - name=value 3-47
 - O 3-46
 - outdir dirname 3-46
 - output resultname 3-46
 - @rsp_file 3-44
 - setup 3-28 3-46
 - Uname 3-47
 - v 3-47
- mex folder 3-3
- mex.bat 4-12
- MEX-file
 - arguments 4-3 5-3
 - C/C++ language 4-1
 - compiling 4-12
 - Microsoft Visual C++ 3-57
 - UNIX 3-33 3-47 3-49
 - Windows 3-52 3-57
 - components 4-2
 - computation error 3-94
 - configuration problem 3-92
 - creating C/C++ language 4-2 4-12
 - creating Fortran language 5-2
 - custom building 3-43
 - debugging C/C++ language 4-32
 - debugging Fortran language 5-24

- DLL linking 3-54
 - documenting 3-17
 - dynamically allocated memory 4-47
 - examples 4-11
 - extensions 3-16
 - load error 3-93
 - passing cell arrays 4-18
 - passing structures 4-18
 - problems 3-91 3-95
 - segmentation error 3-94
 - syntax errors 3-92
 - temporary array 4-47
 - using 3-16
- mex.m 4-12
- mex.sh 4-12
- mexa64 extension 3-16 3-84
- mexAtExit 4-48
 - register a function 4-48
- mexCallMATLAB 4-28 4-47 5-22 to 5-23
- mexCallMATLABWithTrap 4-47
- mexErrMsgIdAndTxt 5-10
- mexErrMsgTxt 4-47
- mexEvalString 3-17
- mexFunction 4-2 5-2
 - altered name 5-25
 - parameters 4-2 5-2
- mexGetVariable 3-17
- mexmaci64 extension 3-16 3-84
- mexMakeArrayPersistent 4-48
- mexMakeMemoryPersistent 4-48
- mexopts.bat 3-55
- mexPutVariable 3-17
- mexw32 extension 3-16 3-84
- mexw64 extension 3-16 3-84
- Microsoft compiler
 - debugging 4-32
- multidimensional arrays 3-23
- mxArray 3-18
 - accessing data 4-2 4-5 5-2 5-5
 - contents 3-18
 - improperly destroying 3-98
- ir 3-23
- jc 3-23
- nzmax 3-23
- pi 3-23
- pr 3-23
- temporary with improper data 3-99
- type 3-18
- mxCalloc 4-14 4-47
 - in gateway routine 4-8 5-10
- mxCopyComplex16ToPtr 5-19
- mxCopyPtrToComplex16 5-19
- mxCopyPtrToReal8 5-7 5-16
- mxCreateDoubleMatrix
 - in gateway routine 4-8 5-10
- mxCreateNumericArray 4-24
- mxCreateSparse
 - in gateway routine 4-8 5-10
- mxCreateString 4-14
 - in gateway routine 4-8 5-10
- mxDestroyArray 3-97 5-30
- mxFree 3-98
- mxGetCell 4-18
- mxGetData 4-18 4-24 to 4-25
- mxGetField 4-18
- mxGetImagData 4-24 to 4-25
- mxGetPi 4-23 5-16
- mxGetPr 4-17 4-23 5-16
- mxGetScalar 4-13 4-17
- mxMalloc 4-14 4-47
- mxRealloc 4-14 4-47
- mxSetCell 3-98
- mxSetData 3-99 3-101
- mxSetField 3-98
- mxSetImagData 3-99 3-101
- mxSetIr 3-101
- mxSetJc 3-101
- mxSetPi 3-99 3-101
- mxSetPr 3-99 to 3-100
- mxUNKNOWN_CLASS 5-23

N

Name

- serial port property 13-104

ndims

- using with Java arrays 7-34

- nlhs 4-2 to 4-3 5-2 to 5-3

- nrhs 4-2 to 4-3 5-2 to 5-3

- null modem cable 13-7

- numeric matrix 3-22

- nzmax 3-23 5-21

O

objects 3-22

- serial port 13-27

objects, Java

- accessing data within 7-18

- concatenating 7-16

- constructing 7-13

- converting to MATLAB cell array 7-63

- converting to MATLAB structures 7-63

- identifying fieldnames 7-18

- information about 7-20

- class name 7-20

- class type 7-20

- passing by reference 7-15

- saving and loading 7-17

ObjectVisibility 13-105

options file

- creating new 3-43

- modifying 3-43

- specifying 3-32 3-35

- UNIX template 3-35

- when to specify 3-33 3-36

- Windows template 3-32

OutputBufferSize 13-107

OutputEmptyFcn 13-108

overloading Java methods 7-56

P

Parity 13-109

- parity bit 13-14

- passing data to Java methods 7-48

- passstr.F 5-15

- persistent arrays

- exempting from cleanup 4-48

- phonebook.c 4-18

- pi 3-21

- PinStatus 13-110

- PinStatusFcn 13-111

- plhs 4-2 to 4-3 5-2 to 5-3

- pointer

- Fortran language MEX-file 5-16

- Port 13-113

- pr 3-21

- preprocessor macros

- accessing mxArray data 4-5 5-5

- prhs 4-2 to 4-3 5-2 to 5-3

- properties

- serial port object 13-82

- protocol

- DCOM 11-13

R

- read/write failures, checking for 1-13

- ReadAsyncMode 13-114

- reading

- binary data from a device 13-47

- text data from a device 13-45

- record file

- serial port object

- creating multiple files 13-72

- filename 13-73

- format 13-73

- RecordDetail 13-116

- RecordMode 13-117

- RecordName 13-119

- RecordStatus 13-120

- refbook folder 4-11
- references
 - to Java arrays 7-46
- RequestToSend 13-121
- revord.c 4-14
- revord.F 5-14
- routine
 - computational 4-2 5-2
 - gateway 4-2 5-2
 - mex 3-3
 - mx 3-3
- RS-232 standard 13-6

- S**
- save
 - using with Java objects 7-17
- saving
 - serial port objects 13-78
- serial port
 - data format 13-11
 - devices, connecting 13-6
 - object creation 13-27
 - RS-232 standard 13-6
 - session 13-21
 - signal and pin assignments 13-7
- serial port object
 - array creation 13-30
 - callback properties 13-56
 - configuring communications 13-33
 - connecting to device 13-32
 - disconnecting 13-80
 - display 13-29
 - event types 13-56
 - handshaking 13-68
 - input buffer 13-43
 - output buffer 13-37
 - properties 13-82
 - reading binary data 13-47
 - reading text data 13-45
 - recording information to disk 13-71
 - using control pins 13-65
 - using events and callbacks 13-55
 - writing and reading data 13-34
 - writing binary data 13-41
 - writing text data 13-39
- serializable interface 7-17
- server variable 11-2
- session
 - serial port 13-21
- shared libraries
 - data conversion 2-22
 - multilevel pointers 2-50
 - pointers 2-39
 - primitive types 2-18
 - structures 2-53
 - library functions
 - getting information about 2-5
 - invoking functions 2-8
 - passing arguments 2-18
 - passing arguments:general rules 2-20
 - passing arguments:pointers 2-39
 - passing libstruct objects 2-53
 - loading the library 2-4
 - MATLAB interface to 2-1
 - unloading the library 2-4
 - using a compiler 2-4
- shared libraries directory
 - UNIX 1-6
 - Windows 1-6
- sincall.c 4-28
- sincall.F 5-22
- size
 - using with Java arrays 7-33
- SOAP 12-2
 - functions 12-5
- sparse arrays 4-27
- sparse matrices 3-23
- start bit 13-13
- static data, Java

- accessing 7-19
- assigning 7-19
- Status 13-122
- stop bit 13-13
- StopBits 13-123
- storing data 3-20
- string 3-22
- struct
 - using with Java objects 7-63
- structures 4-18
- structures, MATLAB 3-22
 - converting from Java object 7-63

T

- Tag
 - serial port property 13-124
- temporary arrays 4-47
 - automatic cleanup 4-47
 - destroying 3-98
- temporary memory
 - cleaning up 3-98
- Terminator 13-125
- text data
 - reading from a device 13-45
 - writing to a device 13-39
- Timeout 13-127
- TimerFcn 13-128
- TimerPeriod 13-130
- timestwo.c 4-12
 - compiling 3-36
- timestwo.F 5-13
 - compiling 3-36
- timestwoalt.c 4-13
- TransferStatus 13-131
- troubleshooting
 - MEX-file creation 3-91
- Type
 - serial port property 13-133

U

- URL
 - Java example 7-66
- UserData
 - serial port property 13-134

V

- %val 5-6
 - allocating memory 5-20
- ValuesReceived 13-135
- ValuesSent 13-137
- variable scope 3-17
- variables 3-18

W

- Web services 12-2
- which
 - using with Java methods 7-26
- Windows
 - automation 11-2
 - COM 11-2
 - mex -setup 3-28
 - selecting compiler 3-28
- workspace
 - caller 3-17
 - MEX-file function 3-17
- write/read failures, checking for 1-13
- writing
 - binary data to a device 13-41
 - text data to a device 13-39
- writing event handlers 10-54
- WSDL document 12-5

X

- xtimesy.c 4-17
- xtimesy.F 5-18